

This document reproduces the complete and unabridged text of a United States Army Field Manual first published by the Department of the Army, Washington DC.

All source material contained in the reproduced document has been approved for public release and unlimited distribution by an agency of the US Government. Any US Government markings in this reproduction that indicate limited distribution or classified material have been superseded by downgrading instructions that were promulgated by an agency of the US government after the original publication of the document.

No US government agency is associated with the publishing of this reproduction.

Digital viewer interface reformatting, viewer interface bookmarks and viewer interface links were revised, edited, ammended, and or provided for this edition by I.L. Holdridge.

This page and the viewer interface reformatting
© I.L. Holdridge 1999.
All rights reserved.

Field Manual
No. 44-18

FM 44-18

HEADQUARTERS
DEPARTMENT OF THE ARMY
Washington, DC, 30 September 1981

**AIR DEFENSE ARTILLERY
EMPLOYMENT
STINGER**

Preface

Advances in weapon systems and electronic technology are significantly affecting military concepts and operations. These advances demand coordinated efficiency on the modern battlefield. Because of the lethality of the threat environment, current doctrine emphasizes winning the first battle. The difference between winning and losing lies in changing tactics to meet the realities of the modern battlefield. Therefore, Stinger personnel must always be prepared to change their tactics to win.

The purpose of this manual is to show — in the setting of the modern battlefield — how Stinger will be employed. This manual describes how the Stinger platoon and section fight. In doing so, it discusses employment of Stinger teams which support the maneuver brigade, battalion task force, field artillery battalion, and covering force. For additional details on how Stinger teams fight, the reader should use FM 44-18-1, Stinger Team Operations.

FM 44-18 is oriented primarily toward the officers and noncommissioned officers— the lieutenants and the sergeants— who will direct and supervise the employment of Stinger and toward those combat arms and combat support commanders who will be supported by Stinger.

★ This manual is unclassified; therefore, threat information contained in this publication is, in some instances, imprecise and incomplete. Where detailed, precise planning is required, authoritative threat sources should be consulted. Classified information pertaining to Stinger capabilities, limitations, and air defense planning can be found in (SNF) FM 44-1A, US Army Air Defense Artillery Operational Planning Data (U).

The material contained herein is applicable without modification to both nuclear and nonnuclear warfare.

Users of this manual are encouraged to submit recommended changes or comments to improve the publication. Comments should be keyed to the specific page and line of the text in which the change is recommended. Reasons should be provided for each comment to insure understanding and complete evaluation. Comments should be prepared on DA Form 2028 (Recommended Changes to Publications and Blank Forms) and forwarded direct to:

★ **Commandant**
US Army Air Defense Artillery School
ATTN: ATSA-TDT-S
Fort Bliss, Texas 79916-7125

Air Defense Artillery Employment STINGER

Table of Contents

		Page
Chapter 1	THE AIR THREAT	1-1
Chapter 2	THE STINGER WEAPON	2-1
Section I	<i>The Stinger Weapon System</i>	2-1
II	<i>The Engagement Process</i>	2-6
Chapter 3	ORGANIZATION AND COMMAND AND CONTROL	3-1
Section I	<i>Stinger Organization</i>	3-1
II	<i>Command and Control</i>	3-7
Chapter 4	COMMUNICATIONS	4-1
Chapter 5	STINGER EMPLOYMENT PRINCIPLES AND GUIDELINES	5-1
Section I	<i>Organization for Combat</i>	5-1
II	<i>Air Defense Planning</i>	5-5
III	<i>Different Defense Considerations</i>	5-10
Chapter 6	STINGER PLATOON OPERATIONS	6-1
Chapter 7	COMBAT OPERATIONS	7-1
★Chapter 8	MANPAD DEFENSE IN NON-ADA UNITS	8-1
Chapter 9	SUPPORT OF SPECIAL OPERATIONS	9-1
Chapter 10	COMBAT SERVICE SUPPORT	10-1

Table of Contents (continued)

Appendix	★A	REFERENCES	A-1
	B	OPERATIONS SECURITY	B-1
	★C	EMERGENCY WARNING SIGNALS	C-1
	★D	SMALL ARMS IN THE AIR DEFENSE ROLE	D-1
Glossary			Glossary-1
★Index			Index-1

This publication implements the following STANAG:

- 2002** Warning Signs Marking of Contaminated or Dangerous Land Areas, Complete Equipments, Supplies, and Stores.
- 2010** Military Land Classification Markings.
- 2019** Military Symbols.
- 2028** System for Field Wire Labeling.
- 2034** Ammunition Supply Procedures.
- 2036** Land Minefield Laying, Recording, and Reporting Procedures.
- 2047** Emergency Alarms of Hazard or Attack (NBC and Air Attack only).
- 2103** Reporting Nuclear Detonations, Radioactive Fallout, and Biological and Chemical Attacks and Predicting Associated Hazards.
- 2104** Friendly Nuclear Strike Warning.
- 2112** Radiological Survey.
- 2129** Recognition and Identification of Forces on the Battlefield.
- 2259** MGD — Terrain.
- 2868** Land Force Tactical Doctrine (ATP-35).
- 2904** Airmobile Operations (ATP-41).
- 3700** NATO Tactical Air Doctrine (ATP-33)(A).
- 3736** Offensive Air Support Operations (ATP-27)(B).
- 3805** Doctrine and Procedures for Airspace Control in the Combat Zone (ATP-40).
- 3880** Counter Air Operations (ATP-42).

When used in this publication, "he," "him," "his," and "men" represent both the masculine and feminine genders unless otherwise stated.

★ "As part of the Army standardization program, the terms squad and team are to be changed to crew. Future revisions of this FM will reflect this changed."

Change
No. 1

FM 44-18
C1

HEADQUARTERS
DEPARTMENT OF THE ARMY
Washington, DC, 17 May 1985

AIR DEFENSE ARTILLERY EMPLOYMENT, STINGER

FM 44-18, 30 September 1981, is changed as follows.

1. New or changed material is identified by a star.
2. Remove old pages and insert new pages as indicated below.

Old Pages

ii, iii, iv, v, vi
1-1 through 1-7
2-1, 2-3 through 2-8
3-1 through 3-17
4-1 through 4-7, 4-9, 4-10
5-1, 5-2, 5-4, 5-6 through 5-8
5-10, 5-11, 5-13 through 5-16
6-3, 6-4, 6-9, 6-10, 6-14
7-5, 7-6
9-10 through 9-12
10-1, 10-3
B-10.....

New Pages

ii, iii, iv, v, vi
1-1 through 1-7
2-1, 2-3 through 2-8
3-1 through 3-20
4-1 through 4-7, 4-9, 4-10
5-1, 5-2, 5-4, 5-6 through 5-8
5-10, 5-11, 5-13 through 5-16
6-3, 6-4, 6-9, 6-10, 6-14
7-5, 7-6
9-10 through 9-12
10-1, 10-3
B-10.....

3. Delete Chapter 8 Add Chapter 8
Delete Appendixes A, C, D, and E Add Appendixes A, C, and D
Delete Glossary Add Glossary
Delete Index Add Index

4. This transmittal sheet should be filed in the front of the publication for reference purposes.

DISTRIBUTION RESTRICTION: This publication contains technical or operational information that is for official Government use only. Distribution is limited to US Government agencies. Requests from outside the US Government for release of this publication under the Freedom of Information Act or the Foreign Military Sales Program must be made to HQ TRADOC, Ft. Monroe, VA 23651.

CI, FM 44-18

By Order of the Secretary of the Army:

JOHN A. WICKHAM, JR.
General, United States Army
Chief of Staff

Official:

DONALD J. DELANDRO
Brigadier General, United States Army
The Adjutant General

DISTRIBUTION:

Active Army, ARNG, and USAR: To be distributed in accordance with DA Form 12-11 A, Requirements for Stinger Team Operations (Qty rqr block no. 491).

Additional copies may be requisitioned from the US Army Adjutant General Publications Center, 2800 Eastern Boulevard, Baltimore, MD 21220-2896.

CHAPTER 1

The Air Threat

Prior to the mid-1960s, Threat air forces were equipped mainly to provide air defense. Threat aircraft were limited in range and payload, being primarily designed as interceptors. In recent years the mission of the Threat air force has been expanded. Missions now include destroying friendly nuclear reserves and tactical air forces and providing tactical air support of ground forces. Through the 1960s, and with increasing tempo through the 1970s, Threat air forces have been receiving new aircraft and munitions with greatly improved offensive capabilities. Older aircraft have been modified to support new missions.

This chapter describes that portion of the air threat that Stinger is designed to neutralize and destroy.

CONCEPT OF AIR SUPPORT

Threat forces recognize that part of their air effort will be initially required to obtain local air superiority. Fighter units of the air army have the dual mission of providing air defense and close support for their ground forces. Attack and bomber units are used to engage targets beyond the range of artillery and to reinforce artillery fires on selected targets and targets of opportunity. A combined bombardment by bombers and ground attack aircraft is coordinated with artillery preparatory fires. After the ground attack has begun, tactical air flies close support missions for ground elements.

Priority tasks for tactical air are the destruction/neutralization of hostile nuclear

delivery means and other targets beyond artillery range.

AIR STRIKES

★ Threat forces consider air strikes an extension of field artillery. They have begun to place great emphasis on tactical air support of ground operations. Attacks are made against preplanned targets to neutralize support and reserves within the tactical operational area. Threat air forces usually do not use high-performance aircraft to provide close air support along the line of contact where artillery can be employed. Armed helicopters are the primary air threat along the forward line of own troops (FLOT).

CONTENTS			
	PAGE		PAGE
Concept of Air Support	1-1	Attack Techniques — Attack Helicopters	1-13
Aircraft and Capabilities	1-2	Tactical Limitations of Attack Aircraft	1-14
Ordnance	1-7	Heliborne Assaults	1-15
Attack Techniques — Fixed-Wing Aircraft	1-8	Airborne Assaults	1-15

AERIAL RECONNAISSANCE

Tactical aerial reconnaissance is a method of gathering intelligence concerning the enemy. It employs airborne collection devices ranging from aircrew eyes to the most advanced sensory devices. The Threat will use reconnaissance aircraft equipped with sensors capable of monitoring US operations in daylight, darkness, and inclement weather. Reconnaissance aircraft

can operate singly or in pairs.

TACTICAL AIRLIFT

The Threat considers tactical airlift operations to be critical both in the conventional and nuclear area. Tactical airlift operations include logistics operations, airborne drops, and assault landings.

AIRCRAFT AND CAPABILITIES

★ Threat forces have been particularly effective in integrating older aircraft and newer, more modern aircraft into a formidable fighting force. Four new aircraft in particular have greatly increased the ground attack capability of Threat forces. Older MiG-21s (FISHBED) are being phased out and replaced with the MiG-23 (FLOGGER B). FLOGGER B is a multirole aircraft with a secondary ground attack capability greater than either the MiG-21 or the Su-7 (FITTER A).

The MiG-27 (FLOGGER D) is the second important new aircraft. Derived from the FLOGGER B, it is designed specifically for ground attack. It is able to carry most new ordnance currently under development.

★ Another new addition is the Su-25 (FROGFOOT). The FROGFOOT with its 10 hardpoints for externally stored munitions and Gatling-type gun, has the same long-loiter, close support mission as the A-10 Thunderbolt II.

★ To supplement this threat, the Su-24 (FENCER) has been fielded. The FENCER is a deep penetration strike aircraft believed equivalent to our F-111. It may be able to underfly friendly radar defenses while conducting deep penetrations.

★ The early MiG-series aircraft (MiGs-15, -17, -19, and -21) were all designed primarily as interceptors to perform an air-to-air com-

bat mission. Early MiGs could only carry two bombs or rocket pods on wing pylons normally used to carry external fuel. Because of this limited ordnance carrying capability, their ability to attack ground targets was limited. Although initial designs of these aircraft go back over a period of 20 years, MiGs -19 and -21 are still being used in large numbers, and the latest models of the MiG-21 are still being produced. Improvements were made to MiG-series aircraft to increase their ground mission capability. As long as an aircraft has utility for combat, it is not scrapped because of obsolescence. In many cases, when replaced in the active threat air force, older equipment is transferred to reserve elements or passed on to Allies.

A review of the Threat's air inventories shows that his air forces can and will employ a wide range of aircraft. Aircraft expected to operate in the forward area can be divided into four categories: multirole aircraft, ground attack aircraft, reconnaissance aircraft, and helicopters.

MULTIROLE AIRCRAFT

★ Multirole aircraft are designed to perform both air-to-air combat missions and ground attack missions. Threat assets within this category include the early MiG-series of aircraft (MiGs-17, -19, and -21), MiG-23/27, and the Su-24.

★ **MiG-17 FRESCO**

TYPE: FIGHTER/INTERCEPTOR/GROUND ATTACK
SPEED AT SEA LEVEL: 1,125 km/hr
SPEED AT ALTITUDE: 1,145 km/hr
RANGE: 1,200 km
ARMAMENT: ONE 37-MM, TWO 23-MM CANNONS,
ROCKET PODS, OR BOMBS



★ **MiG-19 FARMER**

TYPE: FIGHTER/GROUND ATTACK
SPEED AT SEA LEVEL: INA
SPEED AT ALTITUDE: 1,450 km/hr
COMBAT RADIUS: 285 km
ARMAMENT: ROCKET PACKS AND BOMBS, DROP
TANKS; THREE 30-MM CANNONS



★ **MiG-21 FISHBED J**

TYPE: FIGHTER/INTERCEPTOR
SPEED AT SEA LEVEL: 1,100 km/hr
SPEED AT ALTITUDE: 2,250 km/hr
COMBAT RADIUS 465-925 km
ARMAMENT: UNDERWING PYLONS FOR WEAPONS OR
DROP TANKS; ROCKET PACKS; TWIN
BARREL 23-MM CANNON



★ **MiG-23 FLOGGER B/G**

TYPE: FIGHTER/INTERCEPTOR
SPEED AT SEA LEVEL: 1,350 km/hr
SPEED AT ALTITUDE: 2,445 km/hr
COMBAT RADIUS 965 km
ARMAMENT: BOMBS; CBUS; ONE 23-MM TWIN
CANNON RACK

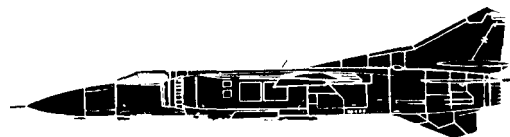

INA-Information not available at the UNCLASSIFIED level.

★ **Su-24 FENCER**



TYPE: MULTIROLE ATTACK/LIGHT BOMBER/
RECONNAISSANCE
SPEED AT SEA LEVEL: 1,530 km/hr
SPEED AT ALTITUDE: 2,320 km/hr
COMBAT RADIUS 400-1,800 km
ARMAMENT: EXTERNALLY CARRIED WARLOADS OF
MORE THAN 5 TONS, INCLUDES BOMBS,
57-MM UNGUIDED ROCKETS, OR FOUR
AIR-TO-SURFACE MISSILES; TWIN BARREL
23-MM CANNON

★ **GROUND ATTACK AIRCRAFT**

Threat aircraft with a primary ground
attack capability are the Su-7B FITTER A,

Su-17/20/22 FITTER C/D, MiG-27
FLOGGER D, and Su-25 FROGFOOT.

★ **Su-7B FITTER A**



TYPE: GROUND ATTACK
SPEED AT SEA LEVEL: 850 km/hr
SPEED AT ALTITUDE: 1,930 km/hr
COMBAT RADIUS 320-485 km
ARMAMENT: ROCKET PACKS AND BOMBS (USUALLY
TWO 1,650 LB AND TWO 1,100 LB); 30-MM
CANNON

★ **Su-17/20/22 FITTER C/D/H**



TYPE: GROUND ATTACK
SPEED AT SEA LEVEL: 1,266 km/hr
SPEED AT ALTITUDE: 2,230 km/hr
COMBAT RADIUS 360-700 km
ARMAMENT: ROCKET PACKS AND BOMBS; 30-MM
CANNON

★ **Su-25 FROGFOOT**



TYPE: GROUND ATTACK
SPEED AT SEA LEVEL: INA
SPEED AT ALTITUDE: 880 km/hr
COMBAT RADIUS: 556 km
ARMAMENT: ROCKETS, BOMBS, AND
MISSILES; 30-MM CANNON

INA Information not available at the UNCLASSIFIED level.

★ MiG-27 FLOGGER D/J

TYPE: GROUND ATTACK
 SPEED AT SEA LEVEL: 1,300 km/hr
 SPEED AT ALTITUDE: 1,800 km/hr
 COMBAT RADIUS 1,200 km
 ARMAMENT: SIX BARREL 23-MM GATLING-TYPE GUN;
 BOMBS (USUALLY 1,100 LBS); 57-MM
 ROCKET PODS; AS-7, AS-9, AND AS-10
 ASMS

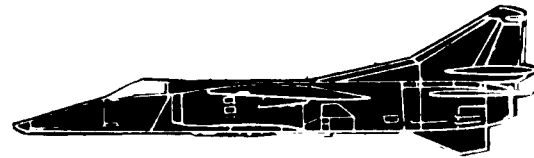

RECONNAISSANCE AIRCRAFT

★ The Threat uses reconnaissance aircraft equipped with photographic and electronic sensors. This equipment is capable of detecting our operations in daylight, darkness, and inclement weather. Reconnaissance aircraft may operate alone, but probably will operate jointly with ground attack aircraft. Used in this manner, reconnaissance aircraft detect targets of opportunity for the ground attack aircraft.

Reconnaissance versions of MiG-21, -23, and -25 aircraft perform deep penetration missions and also provide reconnaissance coverage nearer the forward edge of the battle area. Other aircraft available for reconnaissance missions include the YAK-28 BREWER D and the IL-28R BEAGLE. Reconnaissance missions will often be flown at relatively low altitude, well within Stinger's engagement capability.

★ IL-28R BEAGLE

TYPE: TACTICAL BOMBER/RECONNAISSANCE
 SPEED AT SEA LEVEL: 798 km/hr
 COMBAT RADIUS: 2,260 km
 ARMAMENT: FOUR AUTOMATIC CANNONS (TWO 20-MM, TWO 23-MM); BOMB LOAD, 4,500 LB



★ YAK-28 BREWER D

TYPE: LIGHT BOMBER/RECONNAISSANCE
 SPEED AT SEA LEVEL: INA
 SPEED AT ALTITUDE: 1,175 km/hr
 COMBAT RADIUS: 1,930-2,575 km
 ARMAMENT: INTERNAL BOMB BAY; 30-MM CANNON



INA - Information not available at the UNCLASSIFIED level.

HELICOPTERS

Threat forces have some of the most heavily armed helicopters in the world. These helicopters may be employed near the forward edge of the battle area/line of communications, in the “overmatch,” and in “air assaults” against rear areas.

Helicopters have advantages over fixed-wing aircraft which enable the helicopters to be deployed in large numbers in forward areas. They do not require large airfields or costly runways. They are very suitable for conducting reconnaissance of the enemy's forward forces. They are highly mobile and can fly in weather that grounds fixed-wing aircraft. Finally, they can carry a wide variety of weapons. These include cannons, machine guns, antitank guided missiles (ATGM), freeflight rockets, and grenade launchers.

These valuable characteristics are offset by helicopters' vulnerability to short-range AD weapons. The attack helicopter achieves maximum utility in a war of movement when employed in an ambush or assault action. Using speed, mobility, surprise, and an impressive array of weapons, it can harass, delay, and destroy advancing columns and armor thrusts while supporting the ground attack with firepower.

The Mi-8 HIP is the main utility helicopter for Threat forces and is replacing the Mi-4 HOUND as the standard troop carrier for air assault operations. A new version of the Mi-8 HIP, called HIP E, has been introduced as being equipped with “the heaviest firepower seen on any helicopter in the world.” Rocket and missile launching racks are now included on most 28-passenger Mi-8 transport helicopters.

The Mi-24 HIND is the first Threat helicopter specifically designed for attack missions. However, it is also capable of landing a squad behind enemy lines. The HIND presents a significant threat to maneuver units. There are currently five versions of the HIND. The first three, HIND A, B, and C, differ basically in the ordnance they carry. The fourth version, the HIND D, features a completely redesigned front fuselage. The HIND D's armament capabilities exceed those of the HIND A. Included is a radar-directed nose gun. Another later version is the HIND E which is equipped with triple instead of double missile launch racks under each of its outboard stub wings.

★ Other helicopters likely to be encountered by Stinger personnel include the Mi-2 HOPLITE, Mi-6 HOOK and Mi-28 HAVOC.

★ Mi-8 HIP



TYPE: MEDIUM TRANSPORT AND ASSAULT
 MAXIMUM SPEED: 250 km/hr
 CRUISING SPEED: 225 km/hr
 CARGO: 4,000 kg (INTERNAL) 3,000 kg (EXTERNAL)
 RANGE: 160-410 km
 EQUIPPED TROOPS: 24 ¹²³

★ Mi-4 HOUND

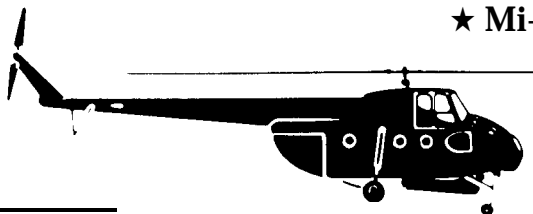

TYPE: TRANSPORT AND GENERAL UTILITY
 MAXIMUM SPEED: 210 km/hr
 CRUISING SPEED: 177 km/hr
 CARGO: 1,200 kg
 RANGE: 460 km
 EQUIPPED TROOPS: 12-16 ¹²³

¹Command raid. ²Airborne cavalry. ³Assault.

★ Mi-2 HOPLITE

TYPE: UTILITY
 MAXIMUM SPEED: 210 km/hr
 CRUISING SPEED: 190 km/hr
 CARGO: 700 kg (INTERNAL) 800 kg (EXTERNAL)
 RANGE: 340-580 km
 EQUIPPED TROOPS: 8-10¹

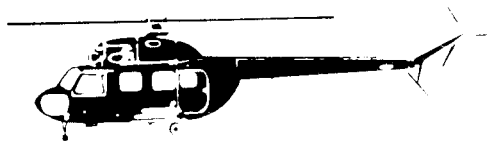

★ Mi-6 HOOK

TYPE: HEAVY TRANSPORT AND ASSAULT
 MAXIMUM SPEED: 300 km/hr
 CRUISING SPEED: 250 km/hr
 CARGO: 12,000 kg (INTERNAL) 8,000 kg (EXTERNAL)
 RANGE: 200-610 km
 EQUIPPED TROOPS: 65^{2,3}

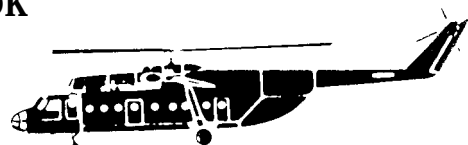

★ Mi-24 HIND

TYPE: ASSAULT
 MAXIMUM SPEED: 320 km/hr
 CRUISING SPEED: 310 km/hr
 CARGO: 3,600 kg
 RANGE: 490-540 km^{1,2,3}
 EQUIPPED TROOPS: 8

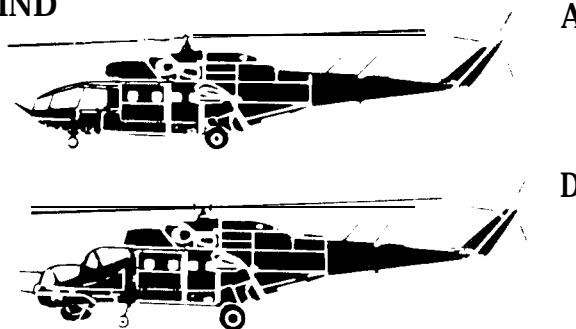

★ Mi-28 HAVOC

TYPE: ATTACK HELICOPTER
 MAXIMUM SPEED: 300 km/hr
 CRUISING SPEED: 480 km
 REMARKS: CARRIES UP TO 16 ANTITANK MISSILES AND HAS AN AIR-TO-AIR CAPABILITY

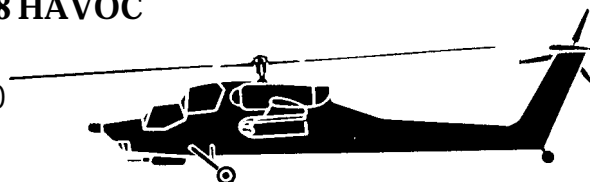

¹Command raid. ²Airborne cavalry. ³Assault

ORDNANCE

Concurrent with the development of aircraft with improved ground attack capabilities has been the development of improved types of ordnance to support this mission. The Threat now has an array of ordnance suited to just about any type of mission or target.

Perhaps most important has been the introduction of effective cluster bomb units

(CBU). A CBU consists of many small bomblets in one package. These can be carried in large numbers on any aircraft. CBUs are dropped at high speeds and low altitudes to cover a wide area.

To improve capabilities against point targets, such as bridges, Threat forces have developed new air-to-surface missiles (ASM) with vastly improved guidance systems.

Guided free-fall bombs, similar to those developed by the West, are also new additions to the Threat's ordnance inventory. Equipped with these new munitions, a single aircraft can now destroy a target that only a few years ago would have defied attacks by large formations.

In addition to employing specialized

munitions. Threat aircraft are equipped with cannons for use in strafing targets. They also can employ unguided bombs of various sizes and 57-mm unguided rockets. These rockets are loaded into a pod which allows a high rate of fire against targets. The table lists the likely targets and characteristics of aircraft ordnances used in attacking ground targets.

TYPICAL THREAT ORDNANCE CHARACTERISTICS & TARGETS		
ORDNANCE	CHARACTERISTICS	TARGETS
CANNON ■ SOLID ARMOR-PIERCING (SAP), HE WARHEADS.	■ VERY ACCURATE. ■ MUST HIT TO KILL. ■ INEFFECTIVE AGAINST HEAVY ARMOR, BUT COULD ACHIEVE MOBILITY KILL BY DAMAGING TRACKS.	■ TROOPS, PARTICULARLY IN OPEN. ■ POL. ■ SOFTSKIN VEHICLES.
ROCKET ■ SAP, AP (HOLLOW CHARGE OR HE WARHEADS.	■ PODS, CLUSTERS. ■ VERY ACCURATE. ■ MUST HIT OR NEAR MISS TO KILL.	■ ARMOR. ■ LIGHT BRIDGES. ■ CPs. ■ SOFTSKIN VEHICLES.
NAPALM ■ HYDROCARBON FUEL + CHEMICAL GEL.	■ DELIVERED FROM 50-200' ALTITUDE. ■ ATTACKING AIRCRAFT MAX SURPRISE/ MIN VULNERABILITY. ■ LESS ACCURATE DELIVERY REQUIRED. ■ BETTER ADHESION TO TARGET.	■ ALL EXCEPT HEAVY STRUCTURES.
BOMBS ■ HE WARHEADS.	■ LARGE DAMAGE ENVELOP RESULTS. ■ RELATIVELY POOR ACCURACY IN DIVE ATTACK.	■ ARMOR (CONCENTRATION ONLY). ■ AREA TARGETS. ■ CONCRETE. ■ FIELD DEFENSES.
CBU ■ AP (HOLLOW CHARGE). ■ FRAGMENTED CASING.	■ AREA WEAPON.	■ GROUPS OF ARMOR. ■ OTHER VEHICLES. ■ PERSONNEL, PARTICULARLY IN OPEN.

ATTACK TECHNIQUES – FIXED-WING AIRCRAFT

Three decades of experience have changed the concept of close air support (CAS). Aircraft are now dedicated to the support of maneuver forces in both Threat and Allied air forces. This is in recognition of the fact that the modern battlefield will provide a number of targets which CAS aircraft can destroy. Threat forces view CAS

air strikes as an extension of their artillery capability.

High-performance aircraft rely on speed for surprise and survival. Because of their high speed, they will strike along the longest axis of the target – this gives them more time on target. They will attack out of the sun to give surprise.

To avoid medium- and high-altitude air defense systems, Threat aircraft operating in the ground attack role will probably approach the target area by flying as low as practical. Most attacks on ground targets near the FEBA will be at altitudes of less than 5,000 feet and at speeds of less than 550 knots.

The air defense gunner should always expect an enemy pilot to do the unexpected. Enemy pilots will deliver ordnance on a target the best way they can. They have several delivery techniques and many variations of these attack techniques at their disposal. The ground attack techniques of most interest to Stinger personnel include lay-down, pop-up, pop-up/lay-down, and standoff.

LAY-DOWN TECHNIQUE

In the lay-down ordnance delivery technique, the pilot uses high speed and low altitude to increase the probability of mission success. He flies the aircraft over the target area about 300 feet above ground level and at a speed of 450-600 knots.

The ability to release ordnance at low altitude is made possible by advances in the development of bomb retardation devices and aircraft avionics. The speed of ordnance fall is reduced by drogue chutes or retarding fins. This allows the aircraft to get out of the way before detonation occurs.

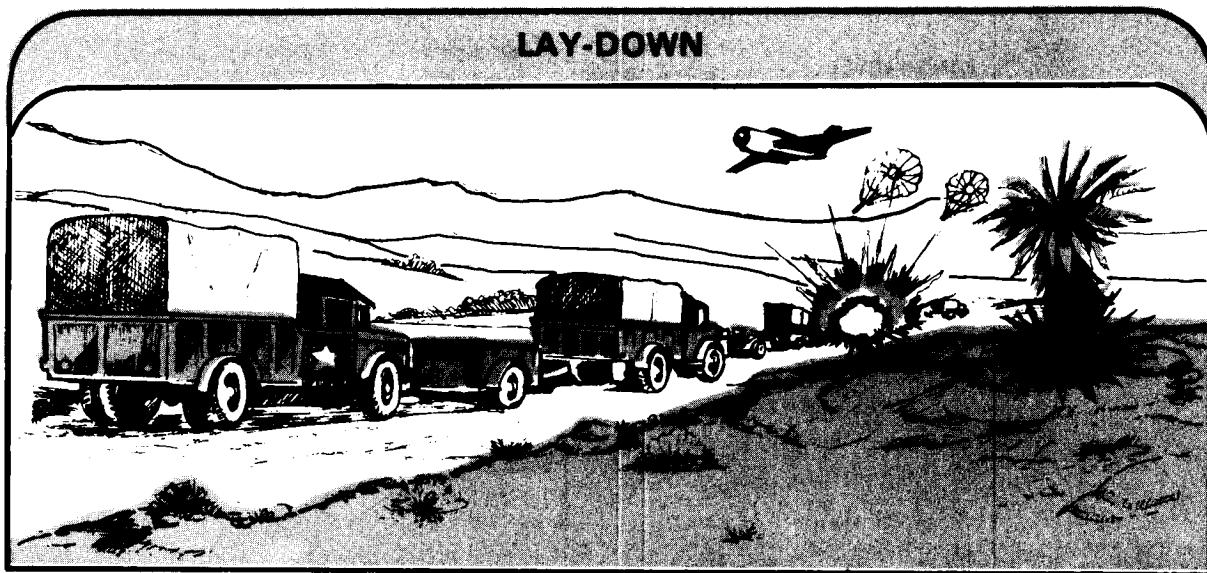

POP-UP TECHNIQUE

The pop-up technique offers the pilot several advantages. By using a low-altitude approach and escape, he minimizes his exposure to air defenses, especially radar-directed air defense systems. He also gains some degree of deception and tactical surprise.

However, offsetting these advantages are several disadvantages. Aircraft consume more fuel at low altitudes, so the pilot has reduced his range. He also has less time to acquire the target than he would at a higher altitude on a clear day. The technique also increases his vulnerability to ground fire.

The pop-up technique generally consists of a run at low level from an initial point (IP) about 10-20 kilometers from the target. The IP is usually a significant terrain feature in the area. The aircraft then flies to a pull-up point (PUP) about 3-8 kilometers from the target where it begins a rapid climb. Once the aircraft reaches attack height, it dives to an ordnance release point. This point will vary according to the type of ordnance being delivered. It is generally located 500-1,500 meters from the target. After delivering ordnance, the aircraft will attempt to escape at high speed.

More specific figures for the pop-up

attack technique are:

- The attack altitude of the aircraft will be from 1,000-5,000 feet, depending on the type of ordnance to be released.
- When the aircraft begins its dive from attack altitude to the ordnance release point, it will usually turn left or right to a new heading which is 20°-90° from the original heading.
- Airspeed during the attack is more a function of the type ordnance being delivered rather than the aircraft's maximum capabilities. For most ordnance, the normal speed varies from 400-500 knots.

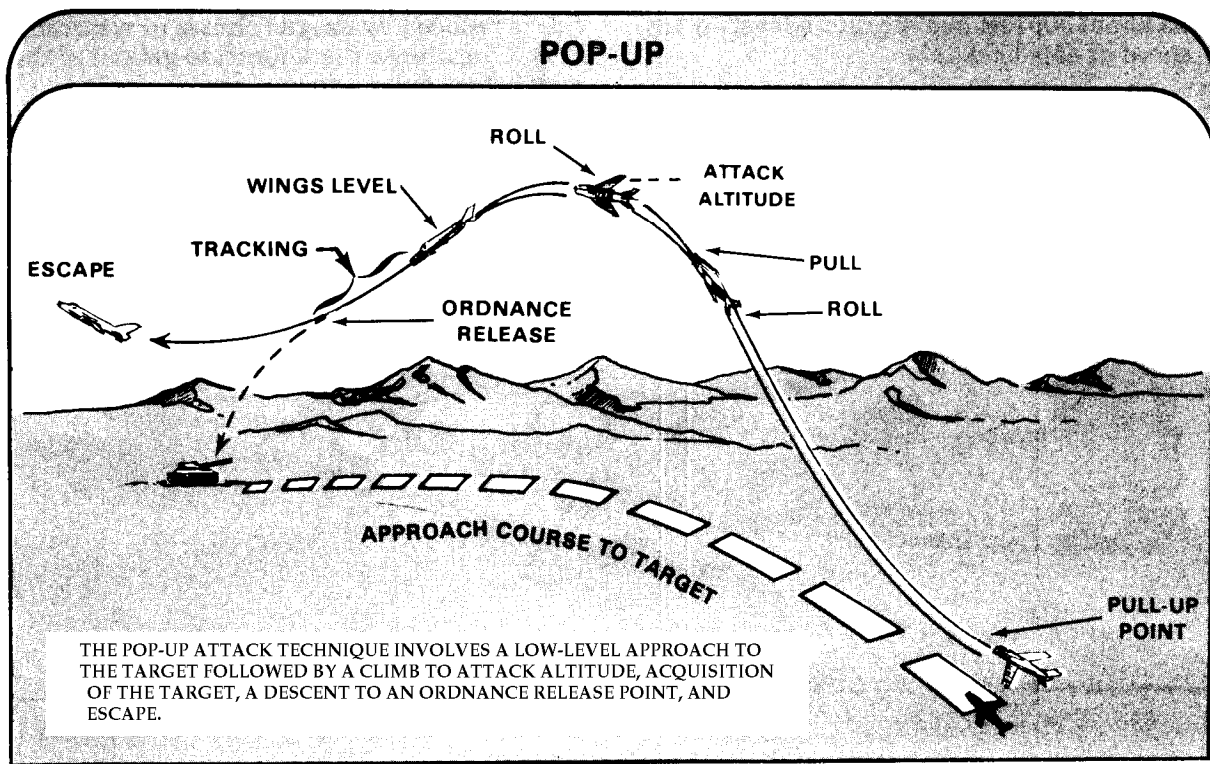

POP-UP/LAY-DOWN ATTACK

An attack may be made on a convoy by a flight of four aircraft armed with various

munitions and initially flying low to avoid ADA radar detection. The lead aircraft spots

the convoy and notifies the others. They will probably separate into two elements of two aircraft each. (With a flight of only one or two aircraft, the maneuver and attack techniques would be similar to those of the lead element in the scenario. The aircraft would spot the column, execute a turn, and attack using

either the pop-up or lay-down technique.) The presence of ADA guns will normally limit the attack to one pass. The probability of aircraft survival decreases as the time and opportunities available for ADA engagement increase.

DIVERTING ATTENTION

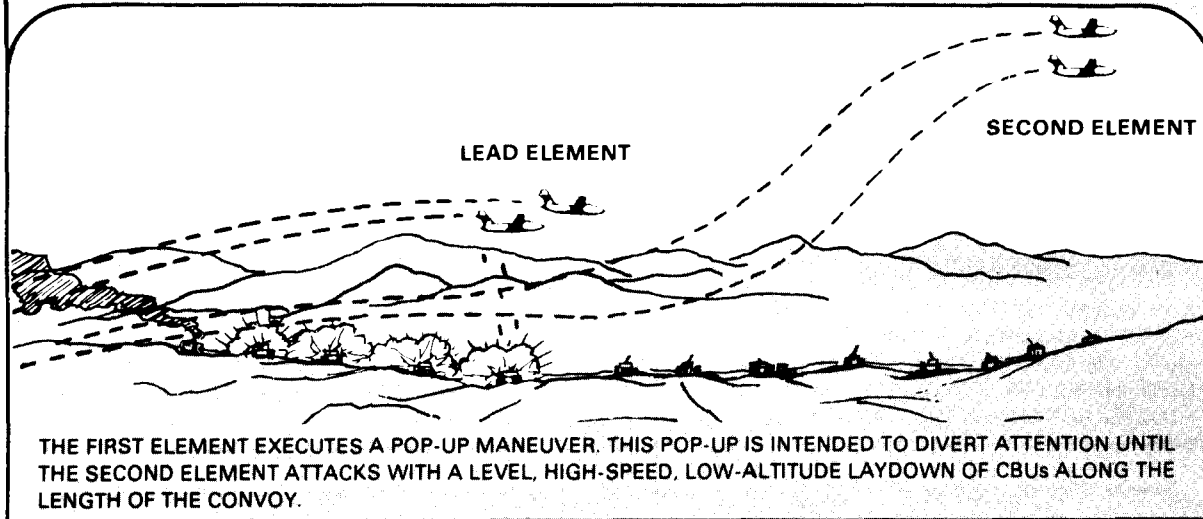

REVERSING MANEUVER

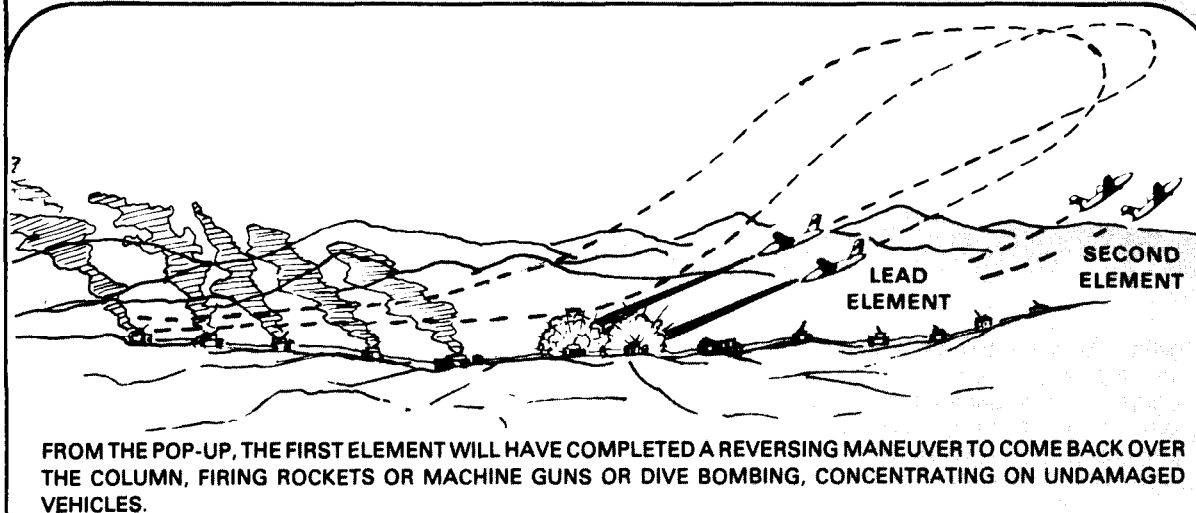

STANDOFF

In the standoff ordnance delivery technique, ordnance is released from aircraft at a considerable distance from the intended target. "Smart" bombs (with electronic steering) and guided missiles are used to

achieve a high probability of hit and kill. These bombs and missiles are equipped with advanced homing guidance systems, such as active and passive infrared (ir), TV-command, and laser.

TV COMMAND SYSTEM STANDOFF

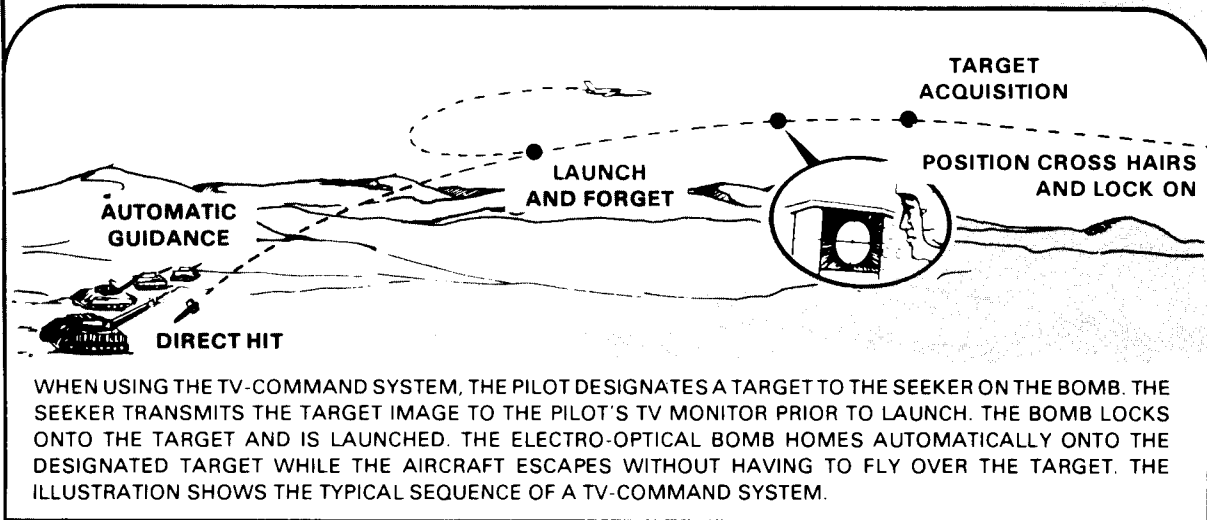

LASER STANDOFF SYSTEM

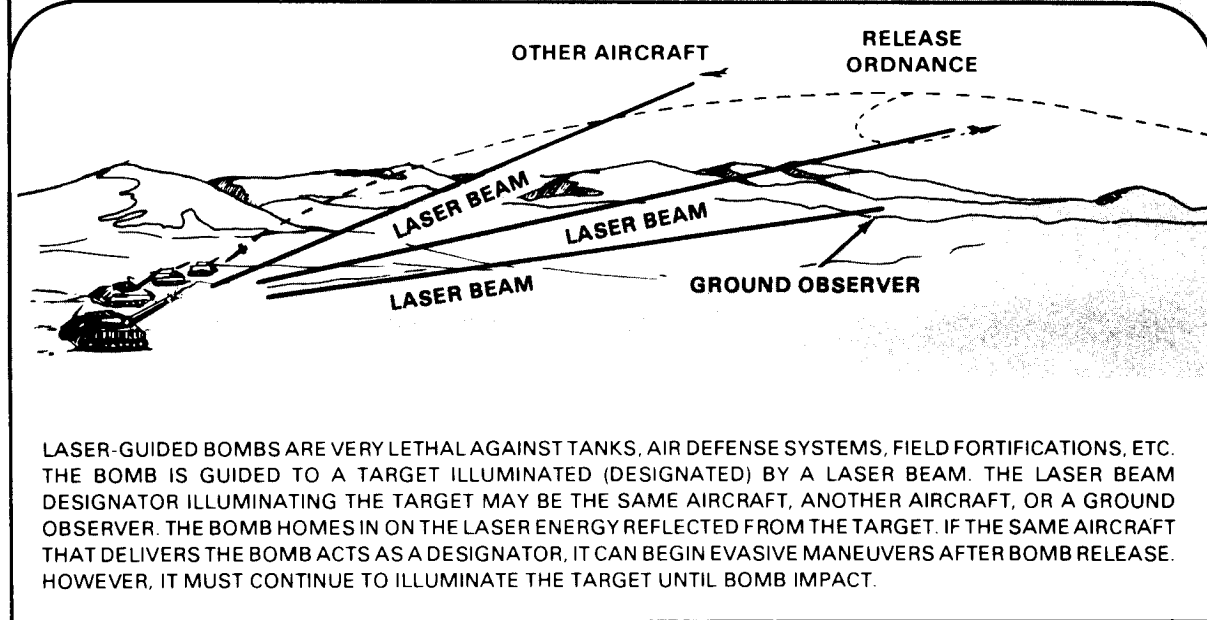

REMEMBER

THE REASON YOUR TEAMS SHOULD BE POSITIONED A CONSIDERABLE DISTANCE FROM THE DEFENDED ASSET IS TO DESTROY THE ENEMY AIRCRAFT BEFORE THE PILOT RELEASES HIS ORDNANCE.

ATTACK TECHNIQUES - ATTACK HELICOPTERS

Attack helicopters (AH) move on the battlefield at the lowest possible altitude, often flying among trees and buildings. Because they are more agile and maneuverable than fixed-wing aircraft, AH can use ground cover to hide behind while engaging from standoff positions. They stay relatively close to the ground, especially when firing. Therefore, attack helicopters are difficult to acquire and, because they are seen as part of the ground clutter by radar-directed air defense systems, are hard to lock onto and engage. Many Threat helicopters are equipped with ATGMs.

The attack helicopter, using nap-of-the-earth and sneak-and-peek techniques, will survey the battlefield for targets. Finding a tank for example, the helicopter will use some sort of natural terrain like a forested area or

hill to hide behind and, when the opportunity presents itself, will pop up over the terrain feature and launch its ATGM(s) at the target.

Because it has to visually guide the ATGM to the target, the helicopter is vulnerable to short-range air defense (SHORAD)-type weapons as the helicopter hovers. However, Threat advances in ordnance may eliminate this vulnerability in the near future.

Since helicopters can illuminate ground targets through use of a flare system, there is also a possibility that they may attack our forces at night. The principal advantage of using flares is that they reduce aircraft vulnerability by adding an element of surprise.

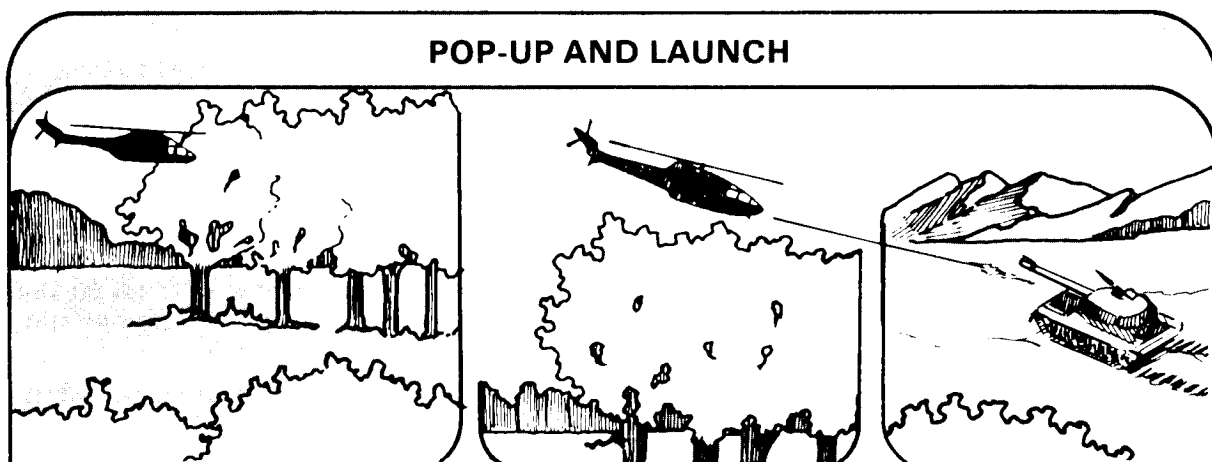

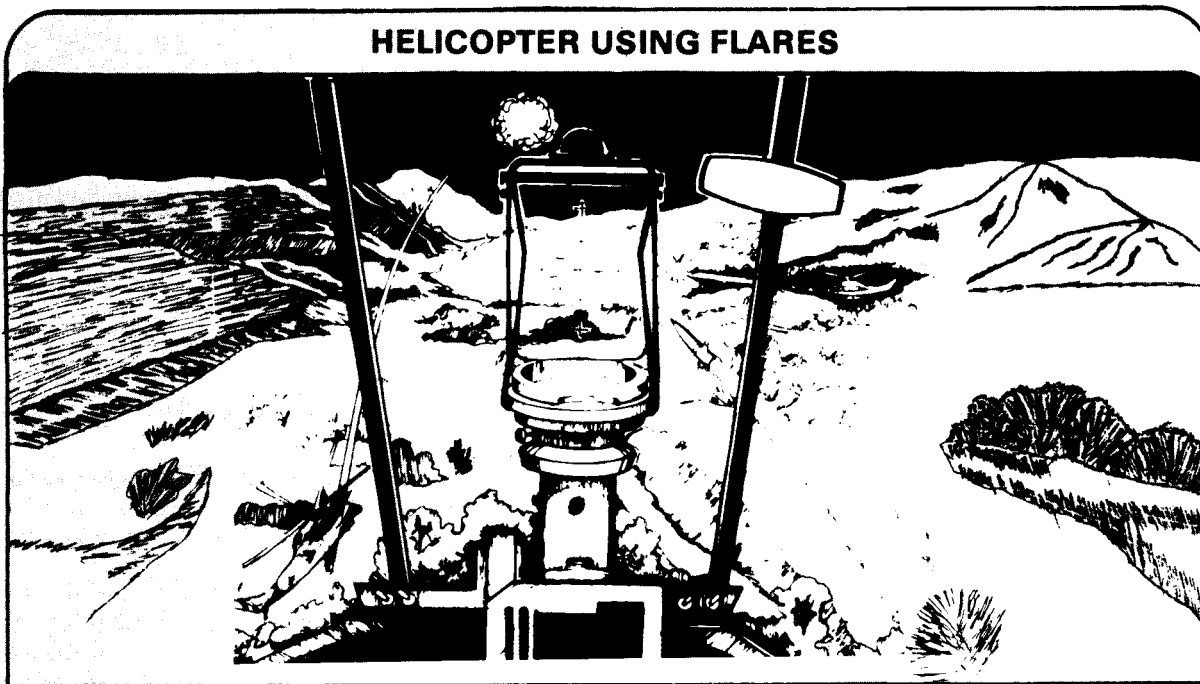

TACTICAL LIMITATIONS OF ATTACK AIRCRAFT

All weapon systems have their limitations, and Threat attack aircraft are no exception. These factors not only limit aircraft effectiveness, but can be used against the Threat by our forces. Attack aircraft have a number of tactical limitations.

Aircraft speed, maneuverability, and range decrease as the aircraft's ordnance load increases.

Aircraft control requires some type of formation flying, at least at the start of an attack. This increases the chance of aircraft detection and reduces the possibility of surprise.

Electronic countermeasures (ECM), active infrared countermeasures (IRCM), and the use of other tactics to degrade ADA effectiveness reveal the presence of the enemy. This eliminates an important part of

an aircraft attack — the element of surprise.

Darkness and inclement weather pose navigation and target acquisition problems for pilots, even with aircraft having an all-weather capability. Under these conditions, aircraft will have to fly higher, increasing their vulnerability to ADA fires.

Low-altitude approaches increase aircraft vulnerability to SHORAD and small arms fire.

High-speed and low-altitude approaches may reduce the chance of aircraft detection and engagement, but they also reduce the accuracy of aircraft weapon delivery. These techniques also make it very difficult for the pilot to locate the target, sometimes necessitating a second pass.

Air weapon delivery must be extremely precise to be accurate. The slightest fault in weapons delivery can cause the pilot to miss

his target and fail in his mission. When fired on, even a near miss may cause the pilot to

lose concentration for that split second necessary to accurately deliver ordnance.

HELIBORNE ASSAULTS

Threat forces have placed increasing emphasis on air assault operations in recent years. The mobility of helicopters allows Threat commanders to:

- Assist attacking forces by rapidly surmounting obstacles and large areas of NBC contamination.
- Prevent enemy forces from closing gaps created by nuclear strikes.
- Seize and hold important objectives in the enemy rear until the arrival of advancing troops.
- Raid to destroy control points, radar posts, and signal centers.
- Assist maneuver units by providing a highly mobile antitank capability.

Threat doctrine stresses maintaining the momentum of the attack. Heavy use of an air assault mission is one way to do this. Threat leadership believes that air assault missions

are especially useful after a nuclear strike. Using this type of assault as soon as possible after a nuclear strike maximizes the gains made with the strike and minimizes the risk to air assault forces. Tactical air support, to include assault helicopters, is often used to create a fly-through zone in enemy lines. Tactical air support generally continues until the air assault forces have landed and deployed.

In the past, Threat forces used helicopters to transport small numbers of specially trained airborne troops on air assault missions. Recently, however, emphasis has been placed on using motorized rifle battalions for these missions. Threat leadership believes that these forces can be used with a minimum of training. The threat presented by units with the extensive combat capabilities of a motorized rifle battalion being airlifted behind our lines should not be underestimated.

AIRBORNE ASSAULTS

Airborne assaults are conducted with aircraft from military air transport forces. The mission of airborne forces can be strategic, operational, or tactical.

Strategic missions are usually conducted in division strength. The purpose of this type of mission is to establish a new battle front within a theater of operations. Operational missions are conducted in support of armies or fronts. Units conducting these operations are usually of regimental size or smaller and are dropped from 200 to 400 kilometers in the rear. Tactical missions are conducted up to 200 kilometers in the rear. Normal objectives are seizing bridgeheads and critical road or rail junctions, destroying airfields, and

disrupting rear areas. In a nuclear environment, tactical missions are most often used to exploit a nuclear strike.

Although airborne operations can be conducted at almost any time, Threat forces generally conduct them at night. Airborne drops are generally preceded by an increase in reconnaissance of the drop area. Reconnaissance can be conducted by air, clandestine agents, long-range patrols, or air-dropped reconnaissance teams.

Recently, Threat emphasis on tactical airborne missions has decreased. Helicopter assaults are taking their place; however, airborne forces will still be used for operational and strategic missions.

CHAPTER 2

The Stinger Weapon

★ To be able to direct and guide Stinger personnel, Stinger section chiefs and platoon leaders must know the weapon itself. This chapter briefly describes the makeup of the Stinger weapon system. It also describes the basic steps the gunner follows in the engagement process. For a more detailed discussion of weapon characteristics and team firing procedures, refer to FM 44-18-1 and (SNF) FM 44-1A (U).

SECTION I

THE STINGER WEAPON SYSTEM

Stinger is a man-portable, shoulder-fired, infrared-homing (heat seeking) guided missile system. It requires no control from the gunner after firing. Stinger has an identification, friend or foe (IFF) subsystem which aids the gunner and team chief in identifying friendly aircraft. Operations at night or in bad weather are restricted by the gunner's ability to see and identify the target.

The Stinger weapon system is composed of four basic items: weapon round, IFF subsystem, shipping and storage containers, and harness.

THE WEAPON ROUND

The Stinger weapon round is made up of a missile round (consisting of a Stinger missile housed within a launch tube) mated to a separable gripstock. A battery/coolant unit (BCU) is inserted into the weapon round to provide prelaunch power to the system. You must have all three items — missile round, separable gripstock, and BCU — to have an operational weapon. For IFF capability, an IFF interrogator is connected to the weapon.

A basic load of Stinger weapons consists of four weapon rounds and two missile rounds.

MISSILE ROUND

The missile round is composed of two major parts: the missile and a launch tube. The missile is ejected from the launch tube by a missile launch motor. The launch motor is expended and drops from the missile outside the launch tube. Once the missile coasts to a

★ CONTENTS

PAGE	PAGE
<i>Section I The Stinger Weapon System</i>	
The Weapon Round	2-1
Stinger Identification, Friend or Foe, Subsystem	2-3
COMSEC Items	2-4
Shipping and Storage Containers	2-5
Transport Harness	2-6
<i>Section II The Engagement Process</i>	
Launch and Intercept Boundaries	2-6
Engaging Aircraft	2-6

safe distance from the gunner, the missile flight motor fires and continues to propel the missile in flight. Should target intercept not occur within 15-19 seconds after launch, the missile will self-destruct.

The fiberglass launch tube, which houses the missile, provides the main support

for all other parts of the weapon round. Both ends of the launch tube are sealed with breakable disks. The front disk is transparent to ir radiation, allowing the radiation to reach the heat-sensitive missile seeker. Both the front and rear disks break when the missile is launched.

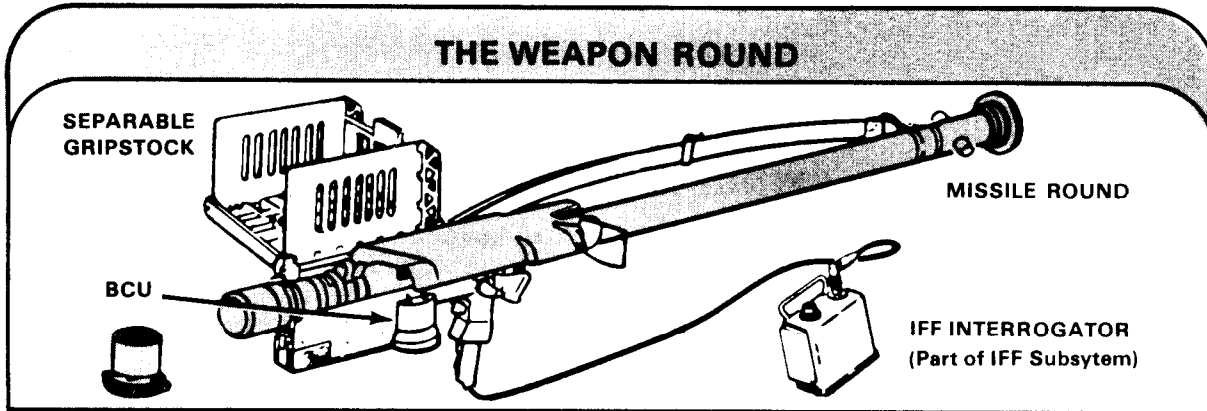

SEPARABLE GRIPSTOCK

The separable, reusable gripstock consists of the gripstock assembly and the IFF antenna assembly.

The gripstock contains all the necessary circuits and assemblies that allow the gunner to prepare and launch the missile. Located on the gripstock assembly are the safety and actuator device, uncaging switch, firing trigger, IFF challenge switch, IFF

interrogator connector, and BCU receptacle. After a missile is launched, the separable gripstock is removed from the launch tube for reuse. The gripstock can be reused until failure. When the IFF antenna assembly is unfolded and the IFF interrogator is connected to the weapon, it is capable of interrogating aircraft and receiving coded replies.

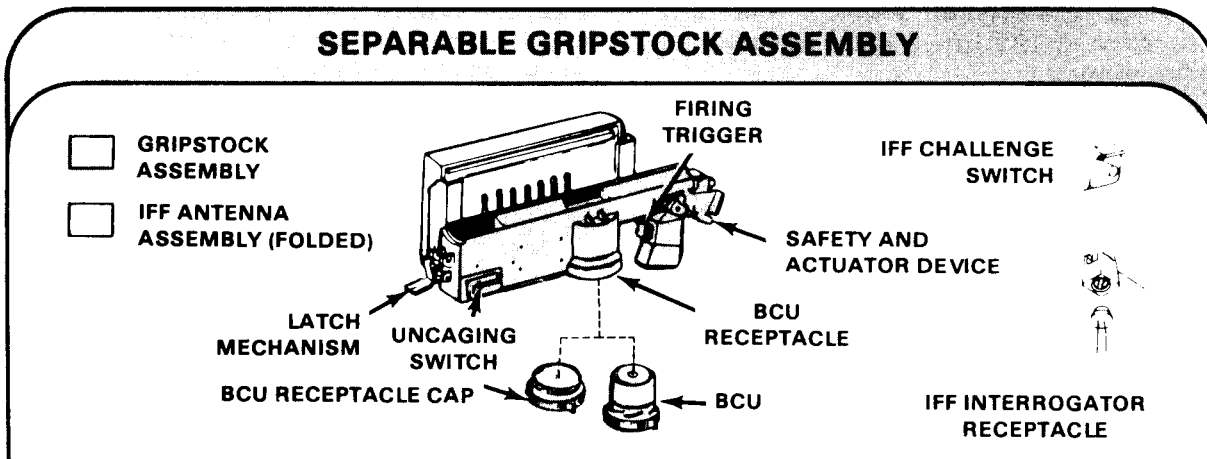

BATTERY/COOLANT UNIT

The battery\coolant unit (BCU) contains a thermal battery to provide power for preflight operation of the system and a supply of argon gas to cool the infrared detector in the missile seeker. Once activated, the BCU supplies electrical power and seeker

coolant to the weapon until launch or for a maximum of 45 seconds. When the system is activated, a BCU is expended. When a BCU is inserted in the weapon, the BCU is considered expended as soon as it is removed. For this reason, three are packed with each missile-round.

STINGER IDENTIFICATION, FRIEND OR FOE, SUBSYSTEM

The Stinger identification friend or foe (IFF) subsystem is a part of the Stinger weapon system. Components of the IFF subsystem used by the gunner are the interrogator and interconnecting cable.

The gunner connects the IFF interrogator to the weapon by using the IFF interconnecting cable. When connected with the Stinger weapon round, the IFF interrogator is capable of transmitting a challenge (interrogation) to a potential target. If an improperly coded reply is received, the aircraft is classified as an "unknown" (possibly a foe). (Detailed IFF interrogation procedures are in FM 44-18-1.)

A programmer/battery charger, code input computer, shipping and storage containers, and code keys are used to support the IFF subsystem. This equipment is located at the section headquarters.

★ The interrogator is programmed with an interrogation code. It can be programmed to operate in Mode 4 secure mode for 4 days. Within 4 days, a new or recharged battery must be installed and the unit reprogrammed. Unless it is reprogrammed, the system automatically shifts from Mode 4 to Mode 3. It remains in this mode of operation until the batteries are discharged or the system is reprogrammed. Two IFF interrogators are issued per team and four interrogators are kept at the section headquarters for spares. Before an IFF interrogator is reprogrammed, a freshly charged battery pack must be inserted. The battery will be charged for a minimum of 4 hours prior to reprogramming of interrogators. A 4-hour charge will

normally allow for 800 interrogations. Operating instructions are found in TM 9-1425-429-12.

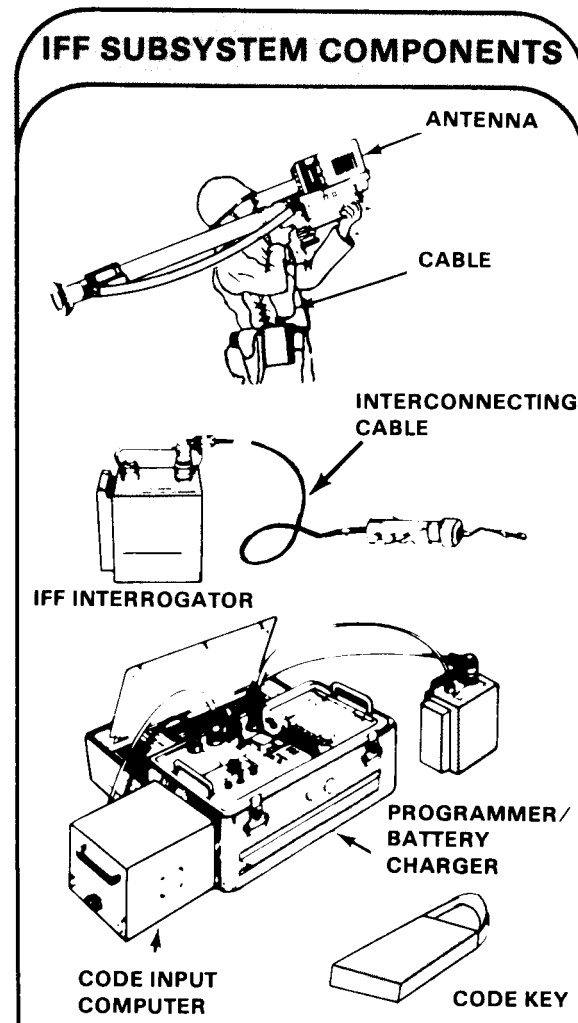

★ COMSEC ITEMS

In addition to the IFF programmer, certain communications security items are required to program the codes into the IFF interrogator.

The TSEC/K1-1A system is the communications security (COMSEC) component of the MARK XII IFF system. Specifically, it

provides the cryptographic security necessary for operating in Mode 4. It is not used to operate in Modes 1, 2, or 3/A. The TSEC/K1-1A system consists of the AKAK 3662 code key list (AKAK), the KIK-18A/T SEC code changer key (KIK), and the KIR-1A/TSEC interrogator computer (KIR) shown below.

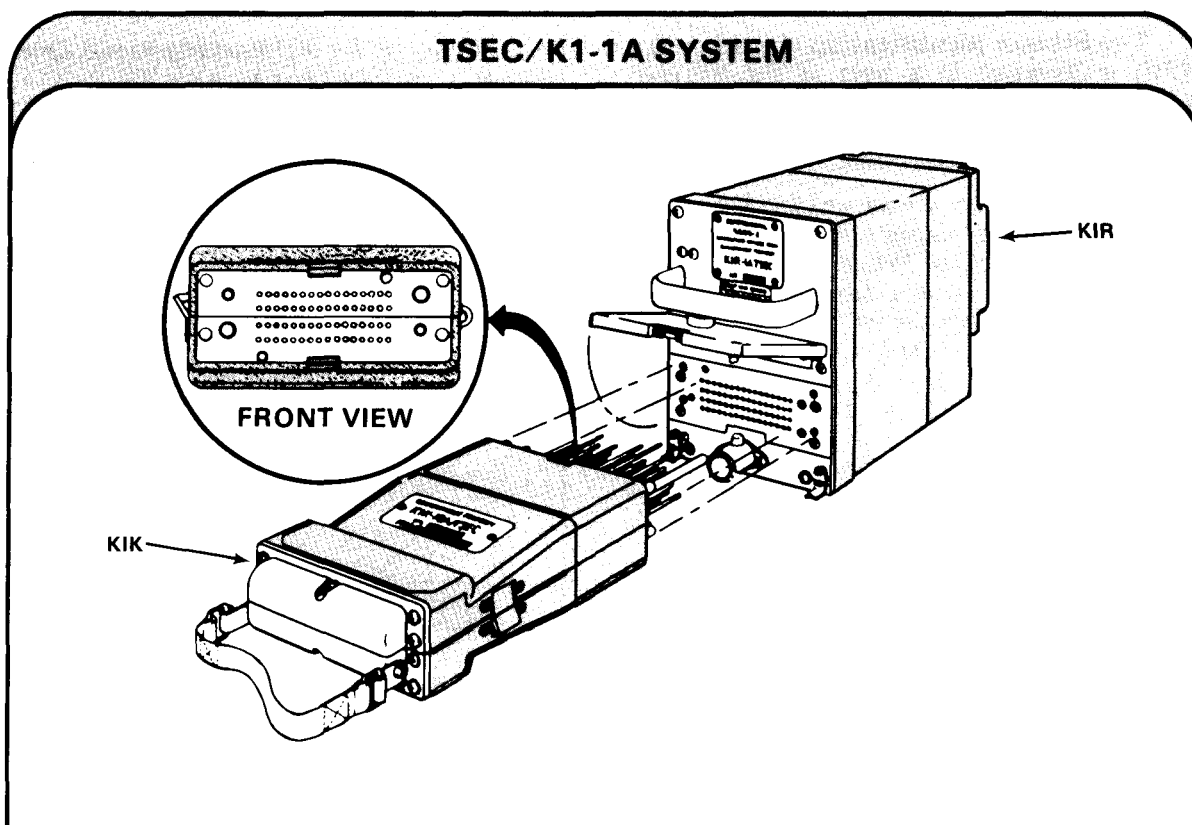

The AKAK 3662 is the operational code key list for the TSEC/K1-1A system. Editions are composed of 28 operational and two emergency tables providing code settings on a 28-day basis. The two emergency tables are not authorized for use. Individual tables consist of 64 metal pins in the KIK. Each table provides two key settings designated "A" +

"B" (Day 1 and Day 2) so that aircraft which are airborne at key change time (2400Z) may shift to the next cryptovisible without rekeying their kit. Editions of the AKAK are classified CONFIDENTIAL and are marked CRYPTO. Individual tables are classified CONFIDENTIAL.

The KIK-18A/TSEC, code changer key is a mechanical device used to cryptographically key the KIR or KIT. The metal pins, which protrude from one end of the device, plug into the code changer assembly of the KIR or KIT to set the code. Once the pins are manually set, the KIK may be used to key any number of KIRs or KITs. The KIK is classified CONFIDENTIAL when set with a code and UNCLASSIFIED when not set.

The KIR-1A/TSEC interrogator computer is used primarily in the ground/surface

interrogator of MARK XII-equipped IFF systems. After being cryptographically keyed by the KIK, the KIR can compute individually unique interrogations that are transmitted as challenges through an interrogator to an unidentified aircraft. It also verifies the validity of the coded replies from the aircraft's transponder. The KIK is classified CONFIDENTIAL. Handling instructions are contained in TB 380-41 and NSA manual KAM 25.

★ SHIPPING AND STORAGE CONTAINERS

The weapon-round container is a reusable aluminum box used for storing an operational weapon round, two spare BCUs, and a set of ear plugs. Four of these containers are issued to each team as part of its basic load. When the weapon-round containers are arranged in the team's ¼-ton trailer, the two top weapon-round containers are converted into "ready racks." The latches of the two top containers are released after securing the containers in the trailer, thereby making the weapons readily accessible to team members.

The missile-round container is a wooden box containing a missile round, three BCUs, and one set of ear plugs. Two missile-round containers are issued to each team as part of its basic load. As rounds are expended, the gunner simply opens a missile-round container, removes the missile round, mates the gripstock of the expended round to the new missile round, and inserts a BCU. He then has a complete weapon round to use if needed. The empty box is then returned to the trailer. Replacement missile rounds are stored at ammunition supply points (ASP).

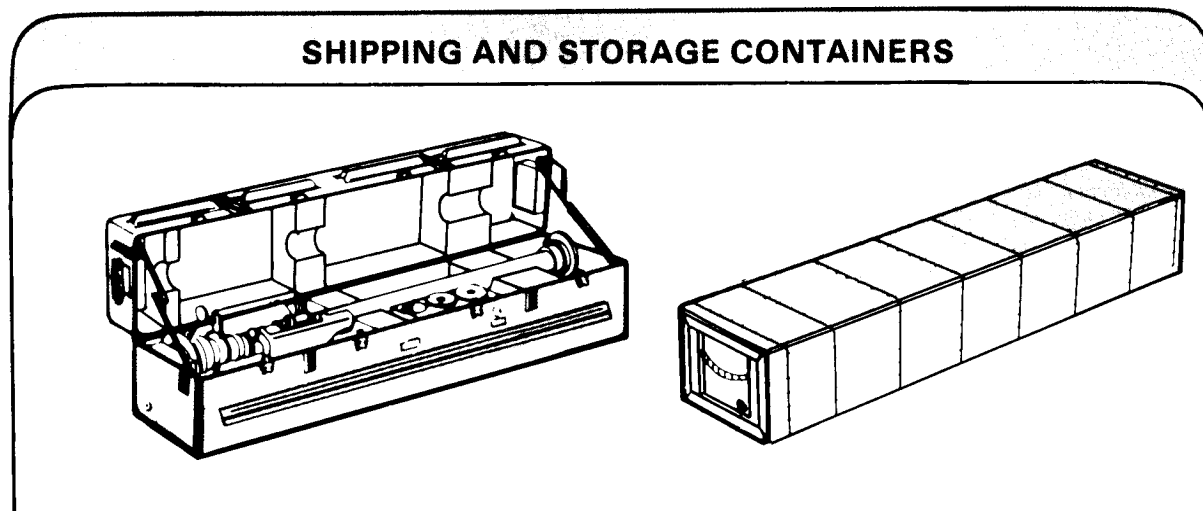

TRANSPORT HARNESS

The Stinger basic load is carried on the standard ¼-ton cargo trailer and is held in place by a transport harness. The transport

harness is used to secure the basic load on the trailer. The harness also allows rapid access to the two top weapon-round “ready racks.”

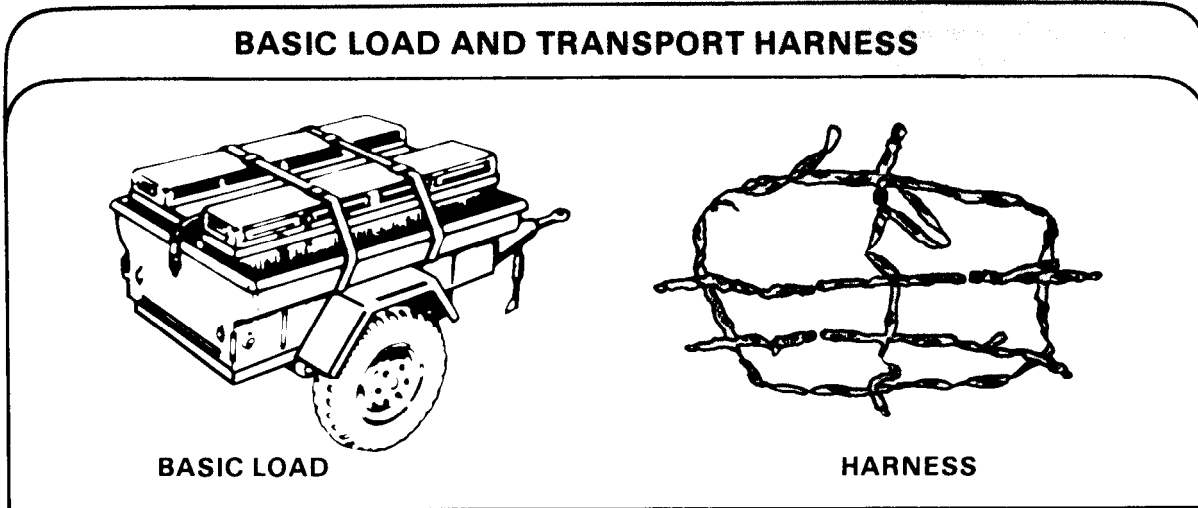

SECTION II

THE ENGAGEMENT PROCESS

★ LAUNCH AND INTERCEPT BOUNDARIES

The engagement process is influenced by Stinger's launch and intercept boundaries, and the size and shape of the boundaries are influenced by many factors. Among these are the type, speed, altitude, and aspect of the aircraft. Stinger can effectively engage all aircraft operating at low level and at

ordnance delivery speeds. Proper employment of the Stinger weapon requires understanding of its capabilities and limitations. For a more detailed discussion of Stinger launch and intercept boundaries and other classified information, refer to (SNF) FM 44-1A (U).

ENGAGING AIRCRAFT

The engagement process consists of a series of actions performed by the Stinger team. The team chief and gunner are trained

to rapidly perform the procedures, as shown on next two pages.

THE ENGAGEMENT PROCESS

GUNNER (G)

TEAM CHIEF (TC)

1 SEARCH AND SCAN

THE GUNNER BEGINS SEARCHING FOR TARGETS AS DIRECTED BY TEAM CHIEF. SEARCH AND SCAN MAY BE DONE BY EITHER TEAM MEMBER. WHEN WARNING OF THE APPROACH OF UNKNOWN AIRCRAFT IS RECEIVED, THE GUNNER CAN NARROW THE SEARCH SECTOR TO THE GENERAL DIRECTION FROM WHICH THE AIRCRAFT IS COMING.

2 TARGET DETECTION

THE GUNNER ASSISTS THE TC TO DETECT THE TARGET.

3 SHOULDER WEAPON AND TRACK

ONCE THE AIRCRAFT IS DETECTED (IDENTIFICATION MAY OR MAY NOT HAVE TAKEN PLACE), THE GUNNER POSITIONS HIS STINGER WEAPON SO THAT THE AIRCRAFT'S IMAGE IS ALIGNED WITHIN THE RANGE RING OF THE WEAPON SIGHT. THE GUNNER MAINTAINS THE AIRCRAFT IMAGE WITHIN THE SIGHT CONTINUOUSLY THROUGHOUT THE FIRING SEQUENCE.

ARM AND UPPER BODY MOVEMENTS WHILE THE GUNNER IS TRACKING THE AIRCRAFT DETERMINE WHETHER THE AIRCRAFT IS ON A CROSSING FLIGHT PATH OR ON AN INCOMING/OUTGOING FLIGHT PATH. HORIZONTAL ARM AND UPPER BODY MOVEMENT INDICATES A CROSSING TARGET. VERTICAL ARM AND UPPER BODY MOVEMENT INDICATES AN INCOMING/OUTGOING AIRCRAFT.

4 INTERROGATE AIRCRAFT

TO INTERROGATE AN AIRCRAFT, THE GUNNER AIMS THE WEAPON AT IT AND PRESSES THE IFF CHALLENGE SWITCH. THE AIRCRAFT TRANSPONDER TRANSMITS A CODED REPLY TO THE STINGER IFF. THE REPLY IS ELECTRONICALLY EVALUATED FOR CORRECTNESS AND THE IFF SYSTEM FURNISHES AN AUDIBLE SIGNAL INDICATING WHETHER THE AIRCRAFT IS A TRUE FRIEND (MODE 4), POSSIBLE FRIEND (MODE 3), OR UNKNOWN. REFER TO CHAPTER 3 FOR THE DIFFERENT IFF MODES AND HOW THEY ARE USED TO AID THE STINGER TEAM IN IDENTIFICATION.

5 ACTIVATE WEAPON

THE TEAM CHIEF WILL ORDER THE GUNNER TO

1 MONITOR TADDS AND RADIO

THE TC MONITORS TARGET ALERT DATA DISPLAY SET (TADDS) AND RADIO FOR EARLY ALERT.

2 TARGET DETECTION

EARLY DETECTION IS CRITICAL. BOTH MEMBERS OF THE TEAM MUST BE HIGHLY SKILLED IN THIS TASK. WITHOUT THIS SKILL, THE EFFECTIVENESS OF THE WEAPON WILL BE REDUCED. MANY FACTORS INFLUENCE THE DISTANCE AT WHICH AIRCRAFT ARE DETECTED. THESE INCLUDE, BUT ARE NOT LIMITED TO: SEARCH SECTOR SIZE; TERRAIN MASKING; CONDITIONS OF VISIBILITY; ASPECT AT WHICH AIRCRAFT IS VIEWED; SIZE, SPEED, AND ALTITUDE; AND DEGREE OF CONTRAST WITH BACKGROUND. ONCE DETECTION IS ACHIEVED, TC ORIENTS GUNNER TO THE THREAT'S DIRECTION OF APPROACH.

3 POTENTIAL THREAT DETERMINATION

THE STINGER TEAM CHIEF DETERMINES WHETHER THE AIRCRAFT IS A POTENTIAL THREAT BY OBSERVING ITS DIRECTION OF FLIGHT AND IFF REPLY. IF THE AIRCRAFT'S DIRECTION OF FLIGHT INDICATES THAT IT WILL PENETRATE THE DEFENDED AREA AND THE AIRCRAFT FAILS TO REPLY OR REPLIES INCORRECTLY TO IFF CHALLENGE, THE AIRCRAFT IS JUDGED TO BE A POTENTIAL THREAT.

4 JET/PROP DETERMINATION

THE TEAM CHIEF DETERMINES WHETHER THE AIRCRAFT IS A JET OR PROPELLER-DRIVEN (PROP) AIRCRAFT. ONCE THE TYPE OF AIRCRAFT IS DETERMINED, A JUDGEMENT CAN BE MADE AS TO WHETHER OR NOT THE AIRCRAFT IS WITHIN RANGE OF THE STINGER MISSILE.

5 TARGET IDENTIFICATION

TO ENGAGE AN AIRCRAFT EFFECTIVELY AFTER DETECTION, IDENTIFICATION MUST BE ACCOMPLISHED RAPIDLY. STINGER'S IFF SYSTEM AIDS THE TEAM IN IDENTIFICATION.

VISUAL IDENTIFICATION IS ACCOMPLISHED THROUGH RECOGNITION OF CERTAIN DISTINGUISHING FEATURES OF AN AIRCRAFT. THE SAME FACTORS THAT AFFECT DETECTION RANGE AFFECT IDENTIFICATION RANGE.

THE ENGAGEMENT PROCESS - CONTINUED

GUNNER (G)

TEAM CHIEF (TC)

ACTIVATE HIS WEAPON IF THE AIRCRAFT IS A POTENTIAL THREAT. WEAPON ACTIVATION OCCURS WHEN THE GUNNER PRESSES THE SAFETY AND ACTUATOR DEVICE OF THE WEAPON FORWARD AND DOWNWARD. THIS ACTION ACTIVATES THE BCU AND WARMS UP THE WEAPON FOR OPERATION.

6 IR ACQUISITION/UNCAGING

WHEN A SUFFICIENT AMOUNT OF IR RADIATION IS DETECTED BY THE MISSILE SEEKER, ACQUISITION SIGNALS ARE GENERATED BY THE WEAPON. THESE SIGNALS INDICATE THAT THE MISSILE SEEKER HAS ACQUIRED THE TARGET. THE GUNNER THEN UNCAGES (DEPRESSES THE WEAPON'S UNCAGING SWITCH) UNTIL A STEADY ACQUISITION TONE IS HEARD. THIS LETS THE GUNNER KNOW THAT THE SEEKER HAS LOCKED ON THE TARGET AND IS TRACKING IT.

7 CONTINUE TRACKING AND MAKE SIZE ESTIMATE

THE GUNNER DETERMINES IF THE AIRCRAFT IS WITHIN RANGE OF THE STINGER MISSILE BY APPLYING A (1) TIME-COUNT RULE FOR JETS ON A CROSSING FLIGHT PATTERN OR (2) RANGE-RING MEASUREMENTS (SIZE ESTIMATE) FOR JETS ON AN INCOMING/OUTGOING FLIGHT PATTERN. PROP AIRCRAFT ARE CONSIDERED TO BE WITHIN RANGE AS LONG AS THE WEAPON IS ACTIVATED, A HOSTILE ID IS MADE, AND IR ACQUISITION LOCK-ON IS OBTAINED. REFER TO (C) FM 44-1A FOR A DETAILED DISCUSSION ON RANGE DETERMINATION.

8 SUPERELEVATION, LEAD, AND LAUNCH

THE GUNNER PLACES THE AIRCRAFT IN EITHER THE LEFT, CENTER, OR RIGHT SUPERELEVATION AND LEAD RETICLE OF THE WEAPON SIGHT. HE LAUNCHES THE MISSILE BY HOLDING THE UNCAGING SWITCH DEPRESSED AND SQUEEZING THE FIRING TRIGGER.

6 ENGAGEMENT COMMAND

THE STINGER TEAM CHIEF MAKES THE DECISION TO ENGAGE. IT IS CRITICAL THAT HIS DECISION BE TIMELY AND ACCURATE. HIS DECISION IS BASED ON RULES OF ENGAGEMENT CONTAINED IN THE UNIT SOP AND CRITERIA GIVEN TO HIM BY THE SECTION CHIEF. THE TEAM CHIEF MUST THOROUGHLY UNDERSTAND AIR DEFENSE RULES OF ENGAGEMENT AND THE CONTROL MEASURES APPLICABLE TO THE STINGER SYSTEM. CHAPTER 5 OF FM 44-18-1 PROVIDES EXAMPLES OF DECISIONS MADE UNDER VARIOUS WEAPONS CONTROL STATUSES.

WHEN THE TEAM CHIEF MAKES A FIRM DECISION, HE ISSUES AN ENGAGEMENT COMMAND TO THE GUNNER.

7 ENGAGE TARGET

DURING MULTIPLE RAIDS, THE TEAM CHIEF MAY ALSO HAVE TO ENGAGE TARGETS. AT THIS STAGE OF THE ENGAGEMENT SEQUENCE, HIS PREVIOUSLY READIED WEAPON MAY BE USED. HE ACCOMPLISHES THE SAME STEPS (5 THRU 8) THAT THE GUNNER USES.

8 POST ENGAGEMENT

THE TEAM CHIEF ACCOMPLISHES POST ENGAGEMENT PROCEDURES BY:

- MOVING TEAM TO ALTERNATE POSITION (WHEN REQUIRED).
- READYING ADDITIONAL WEAPONS (WHEN REQUIRED).
- MAKING POST ENGAGEMENT REPORTS (ACCORDING TO SOP).

CHAPTER 3

Organization and Command and Control

To effectively employ Stinger on the battlefield, commanders must know how Stinger units are organized. They must also know the command and control structure of Stinger before they can effectively deploy it.

This chapter discusses Stinger organization and the command and control of Stinger. This chapter also explains how Stinger fires are controlled.

SECTION I

STINGER ORGANIZATION**TEAM**

The basic Stinger tactical element is the team. Teams are subordinate elements of Stinger air defense sections. Each team is composed of a team chief and a gunner. Both team members are trained to perform all team functions. The team normally acts as a unit with the team chief establishing the identity of the aircraft and authorizing the engagement.

When under heavy attack, both team members may act as gunners to increase firepower. In this case, the team chief should

identify the targets, give the gunner an engagement order, and then attempt to engage with a second weapon-round.

Each team is normally equipped with a ¼-ton truck and trailer, with the exception of those teams assigned to the air assault division. In addition, teams have communications equipment, binoculars, target alert data display set (TADDS), and two IFF interrogators. For further information, refer to appropriate tables of organization and equipment (TOE).

SECTION

The Stinger air defense section consists of a headquarters element composed of a section chief and a radiotelephone operator/driver, and a varying number of Stinger teams.

The number of teams in a section depends on the type organization to which the section belongs. The accompanying chart shows the total allocation of Stinger teams and sections in major organizations. A

★ CONTENTS	
PAGE	PAGE
<i>Section I Stinger Organization</i>	
Team	3-1
Section	3-1
Platoon	3-2
Divisional Organization	3-2
Nondivisional Organization	3-6
<i>Section II Command and Control</i>	
What is Command and Control?	3-8
Stinger Command Structure	3-8
Control of Stinger	3-10
Command and Control of the Stinger Platoon	3-11
Command and Control Procedures	3-12

further breakdown of teams and sections within major organizations is discussed later in this section.

The section headquarters has a ¼-ton truck and trailer, communications

equipment, IFF interrogators, an IFF programmer/battery charger, and a TADDS to assist in early warning. For further information, refer to appropriate tables of organization and equipment.

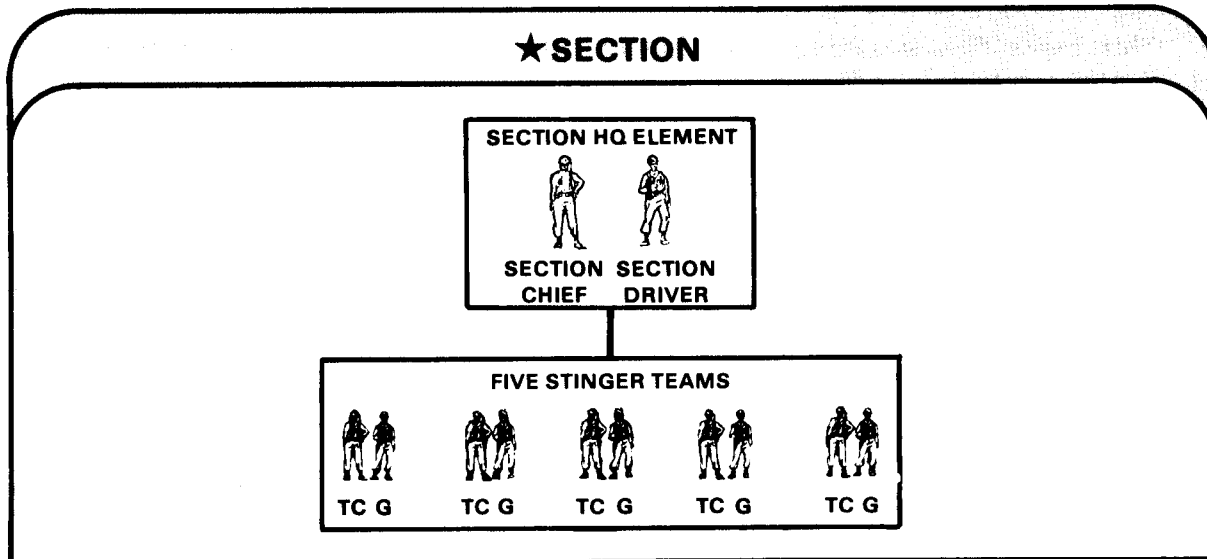

PLATOON

The Stinger platoon is organic to the firing batteries of the divisional ADA battalion. The Stinger platoon has its own TOE and is assigned to the headquarters element in separate brigades and regiments. In divisional ADA, the platoon normally is under the direct command of the ADA battery commander.

The platoon headquarters is composed of a platoon leader, platoon sergeant, and a radiotelephone operator/driver. The platoon headquarters has a ¼-ton truck and trailer. The element also has communications equipment required to command and control the platoon. For further information, refer to appropriate tables of organization and equipment.

DIVISIONAL ORGANIZATION

ARMORED, INFANTRY, MECHANIZED (AIM) DIVISION

Within the divisional organization, each ADA Stinger platoon consists of a headquarters element and four sections. Three sections have five teams; the fourth section has three teams. A total of 4 platoons and 72 teams are in the division. (For task

organization purposes within AIM divisions, each Stinger platoon is designated as the fourth platoon of each Chaparral and Vulcan battery.) Stinger platoons within each AIM division are organized as shown.

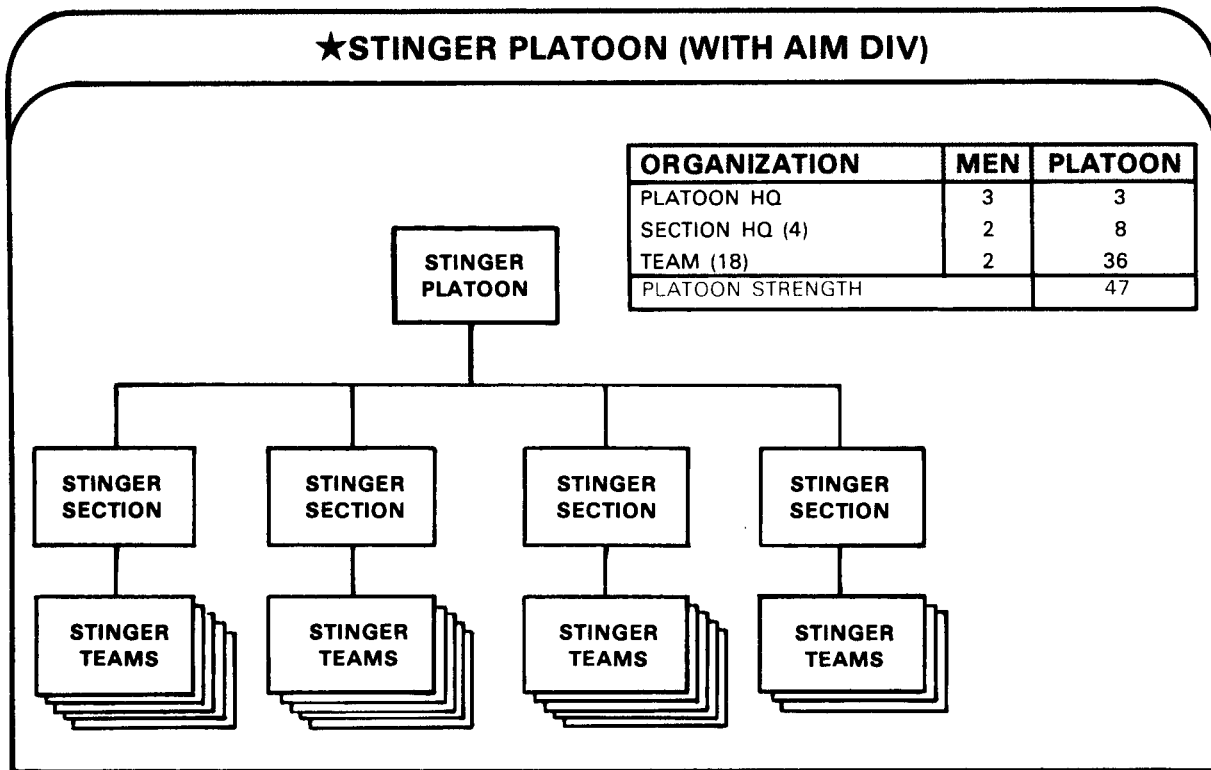

★ ARMY OF EXCELLENCE ORGANIZATIONS

Stinger units which are being transitioned to Army of Excellence organizations are shown below.

STINGER TEAM ALLOCATION		
ORGANIZATION	SECTION	TEAM
DIVISION		
ARMORED	12	60
MECHANIZED INFANTRY	12	60
INFANTRY	8	40
AIRBORNE	12	60
AIR ASSAULT	12	60
MOTORIZED INFANTRY	20	60
BRIGADE (SEP)		
ARMORED	4	16
LIGHT INFANTRY	4	20
INFANTRY	4	16
ARMORED CAVALRY REGIMENT	5	22

★ Heavy Division

A Stinger platoon is organic to each of the three SGT York Gun/Stinger batteries in the ADA battalion of the heavy division. An additional Stinger platoon is assigned to the

headquarters and headquarters battery. A total of four platoons and 60 teams are in the division.

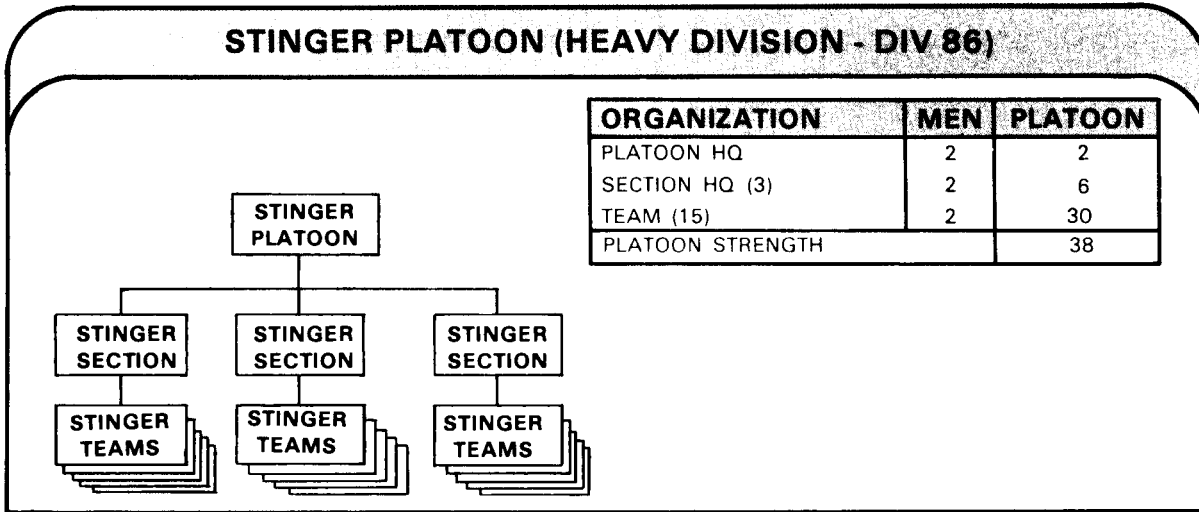

★ Light Division

A Stinger platoon is organic to each of the two LADS/Stinger batteries in the ADA battalion of the light division. Each platoon

has 20 teams for a total of 40 teams in the division.

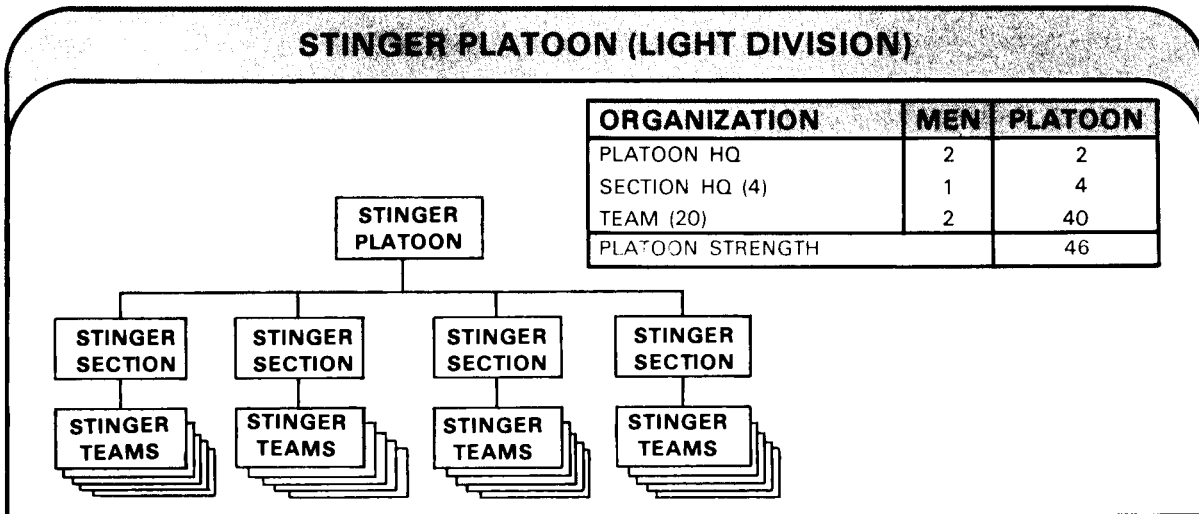

★ Motorized Infantry Division

A Stinger platoon is organic to each of the three gun/missile batteries in the ADA battalion in the motorized infantry division.

Two Stinger platoons are assigned to the Chaparral/Stinger battery. A total of five platoons and 60 teams are in the division.

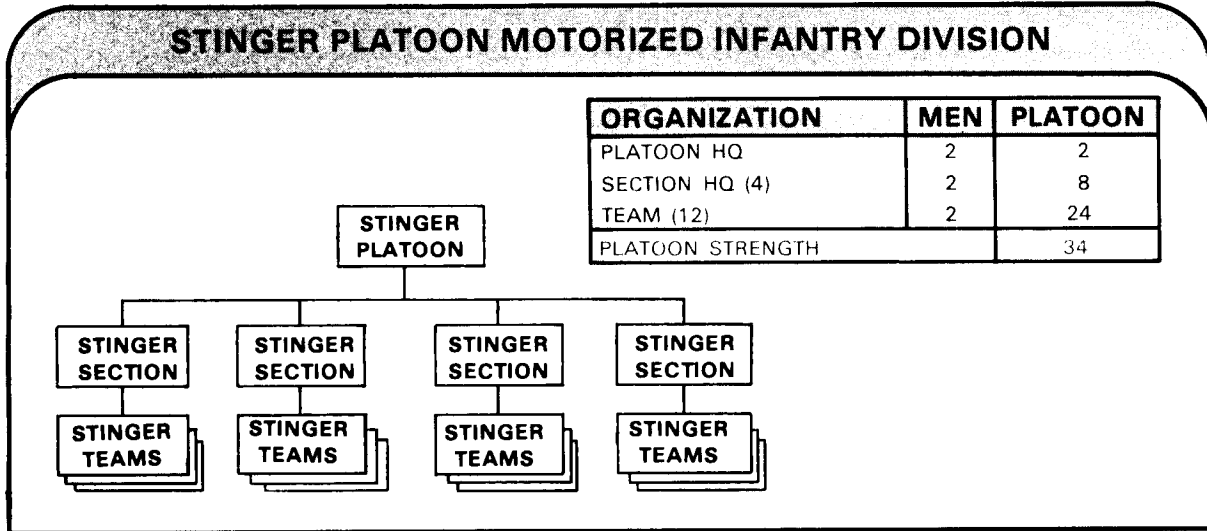

★ Airborne Division

A Stinger platoon is organic to each of the three LADS/Stinger batteries in the ADA battalion of the airborne division. Each platoon has 20 teams for a total of 60 teams in the division.

Each platoon has 20 teams for a total of 60 teams in the division.

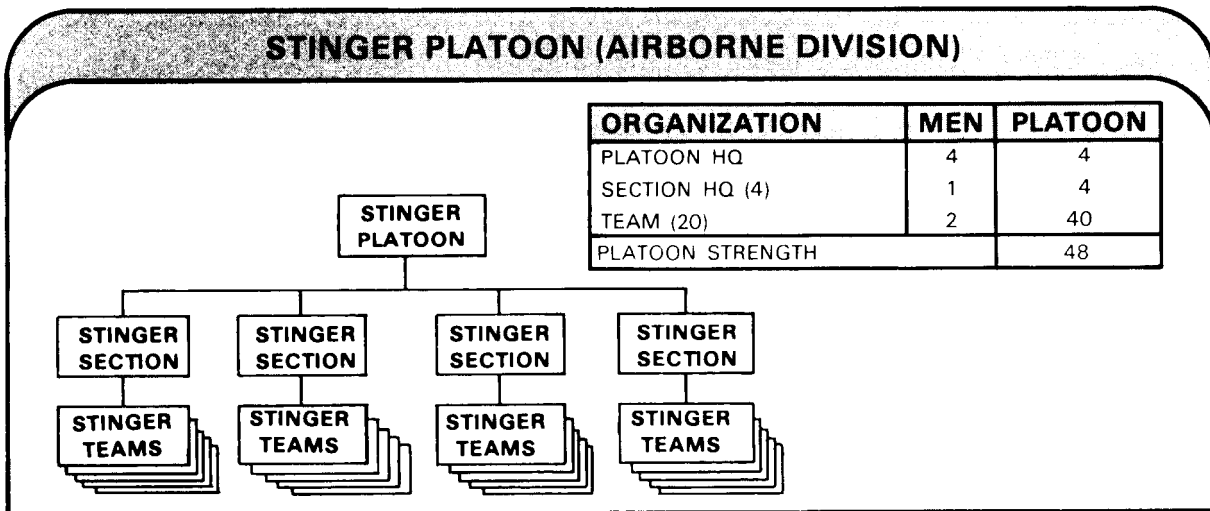

★ Air Assault Division

A Stinger platoon is organic to each of the three LADS\Stinger batteries in the ADA battalion of the air assault division. Each

platoon has 20 teams for a total of 60 teams in the division.

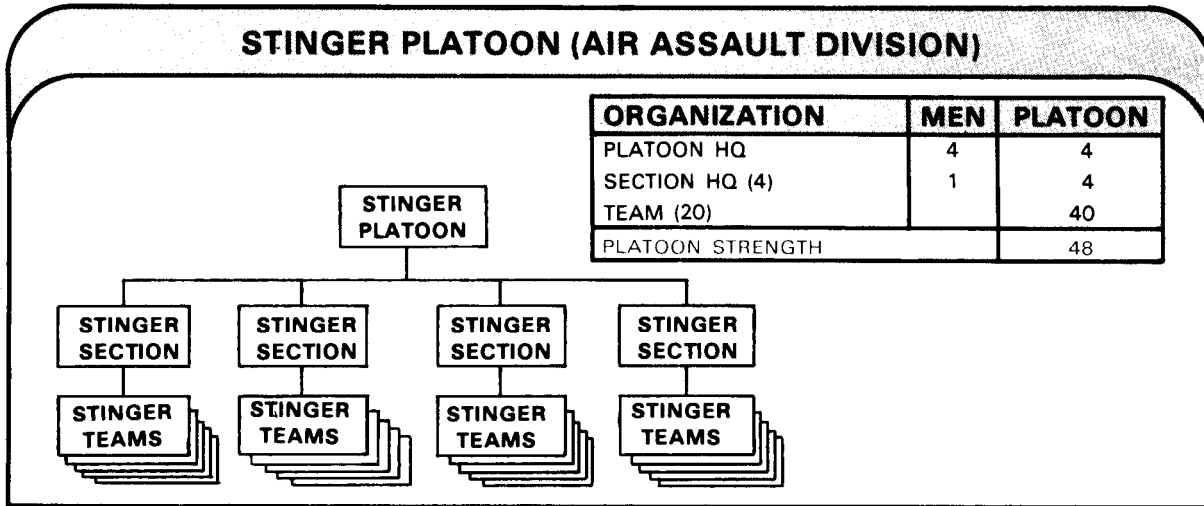

★ NONDIVISIONAL ORGANIZATION

SEPARATE BRIGADE

This platoon is organic to the brigade headquarters element. In separate brigades, the Stinger platoon consists of a headquarter-

ters element and four sections. The sections have four teams as shown below.

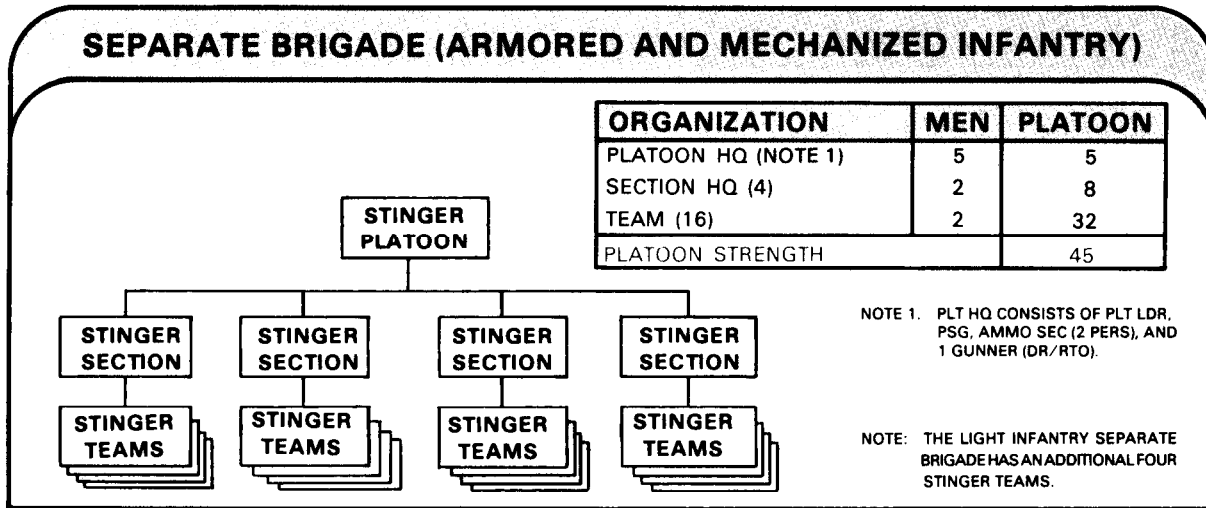

★ ARMORED CAVALRY REGIMENT

In armored cavalry regiments, the Stinger platoon is organic to the regimental headquarters element. The platoon is organized with a headquarters element and five

sections. Four sections have four teams and one section has six teams. The ACR has a total of 22 teams.

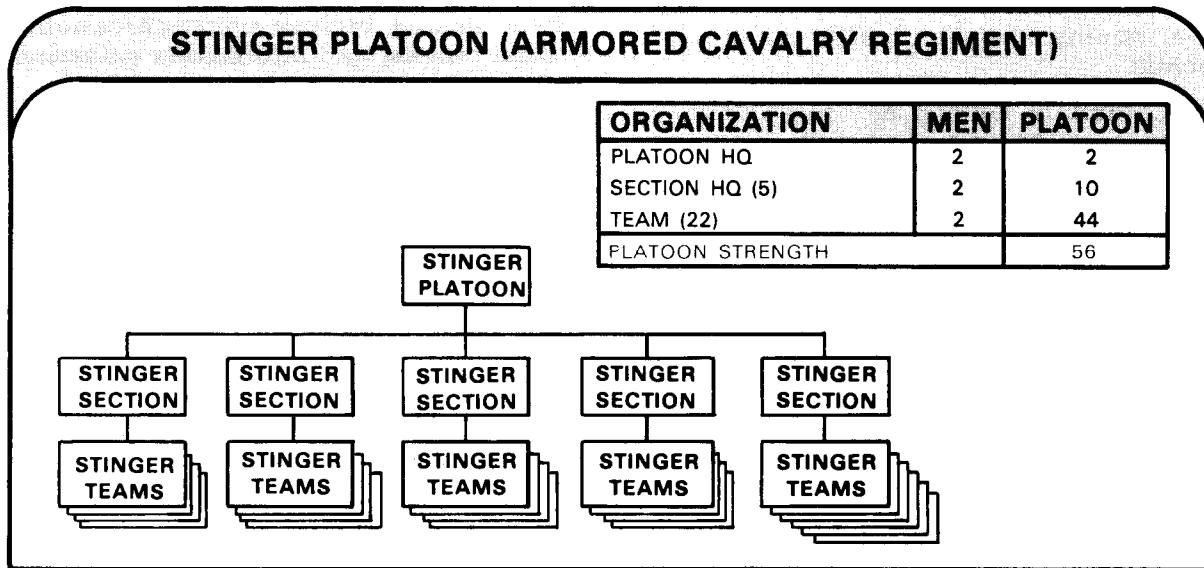

SECTION II

COMMAND AND CONTROL

The full potential of any military force cannot be realized without effective command and control. Command and control of air defense artillery must accomplish two things:

1. Engagement of hostile aircraft while providing for protection of friendly aircraft.
2. Integration of all ADA weapons into one cohesive force so that the appropriate level of firepower will be generated but overkill avoided.

Two factors make command and control of Stinger teams especially challenging:

1. A large number of Stinger teams are on the battlefield.
2. Teams are highly mobile; they remain in one position for only short periods of time.

This section discusses the command and control structure that enables Stinger leaders to perform their mission. The section also explains how Stinger fires are controlled and directed.

WHAT IS COMMAND AND CONTROL?

Command is defined as “the authority and responsibility to use available resources to accomplish assigned missions in accordance with established procedures.” Also included in command, is the authority and responsibility for supply, administration, training, discipline, health, welfare, and morale.

Control is defined as “the authority which may be less than full command exercised by a commander over part of the activities of subordinate or other organizations.”

Together, command and control is the process of directing the activities of military forces to attain an objective. It includes the consideration of —

- Physical means of its accomplishment. These means include communications, control centers, and information gathering systems.
- Staffs and facilities necessary to gather and analyze information, plan for what is to be done, and supervise the execution of what has been ordered.

STINGER COMMAND STRUCTURE

Divisional Stinger. Command for divisional Stinger units follow a relatively simple chain. Within the division, command descends from the division commander to the

air defense artillery battalion and battery commanders and finally to the Stinger platoon and section.

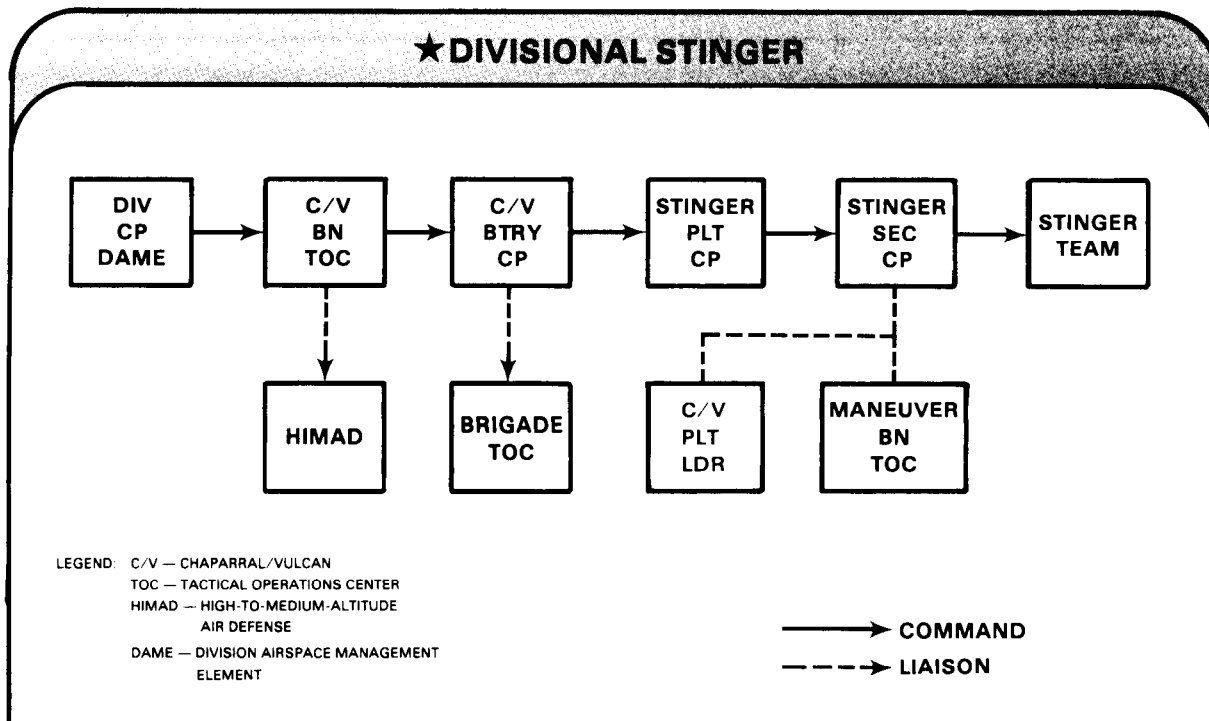

Nondivisional Stinger. Command for nondivisional Stinger also follows a simple chain. A Stinger platoon is organic to the headquarters element of separate brigades or regiments. The commander of the

nondivisional organization to which Stinger is organic sets the priorities for Stinger employment. He also has the positioning authority for Stinger.

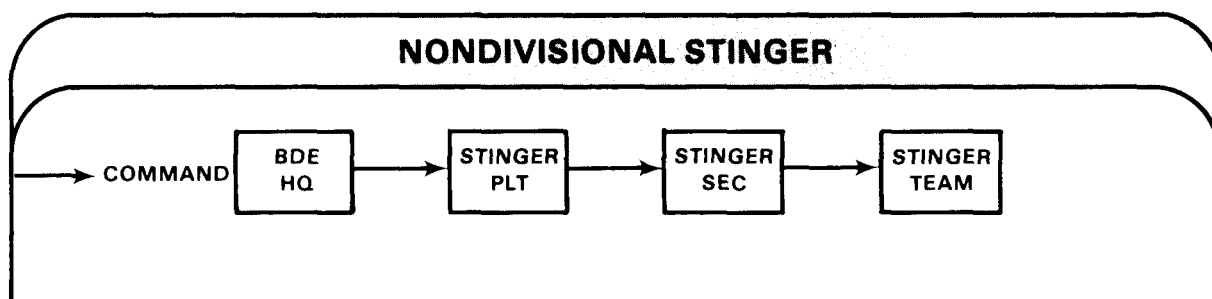

Special Command Statuses. Special command statuses can be formed by attaching or placing the ADA unit under the operational command (OPCOM), operational control (OPCON), or tactical control of another unit. These statuses create special operational, training, administrative, and logistic relationships between the ADA unit, its parent organization, and the receiving unit.

Attachment, US and NATO. Attached ADA units are those placed in an organization on a relatively temporary basis. Subject to the limitations imposed by the attachment order, the commander of the organization receiving the attached ADA element will exercise the same degree of command and control over attached units that he does over units organic to his command. This includes providing administrative and logistic support. However, the responsibility for transfer and promotion of personnel will normally be retained by the parent unit.

Before discussing operational command and operational control, it is important to note that these terms are defined differently in US and NATO environments. In a pure US environment, the term “operational

command” is synonymous to the term “operational control.”

Operational Command/Operational Control, US. In a pure US environment, OPCOM/OPCON gives the commander receiving the ADA unit the authority and responsibility for the composition of subordinate forces, the assignments of tasks, the designation of objectives, and the authoritative direction necessary to accomplish the mission. Administration, discipline, internal organization, logistics, and training are kept by the parent unit unless modified in the operation relationship.

In a NATO environment, OPCOM gives the commander receiving the ADA unit the authority and responsibility to assign missions or tasks, to deploy units, to reassign forces, and to retain or delegate operational and/or tactical control as necessary. It does not include administrative or logistical responsibility.

In a NATO environment, OPCON gives the commander receiving the ADA unit the authority and responsibility to direct forces assigned so that the commander may accomplish specific missions or tasks usually

limited by function, time, or location; to deploy units; and to retain or delegate tactical control of those units. It does not include authority to assign separate employment of the units concerned. Neither does it include administrative or logistic control.

In NATO, tactical control is the detailed and, usually, local direction and control of movements or maneuvers necessary to accomplish missions or tasks assigned. For ADA, tactical control is best defined as fire coordination.

REMEMBER
ATTACHMENT, OPCOM, OPCON, AND TACTICAL CONTROL ARE NOT MISSIONS. THESE STATUSES ARE USED ONLY TO CREATE SPECIAL RELATIONSHIPS BETWEEN ADA UNITS AND RECEIVING UNITS.

CONTROL OF STINGER

Control operates to preclude the engagement of friendly aircraft and to maximize the engagement of hostile aircraft. Control of Stinger is accomplished primarily through the declaration of weapons control statuses and through rules and procedures published in the unit tactical standing operating procedure (TSOP). The authority to engage aircraft is delegated to the team chief. Commanders exercise control by prescribing the precise conditions under which that authority may be exercised.

Air Force), who is appointed by the theater commander. He establishes AD rules and procedures that apply throughout the theater. He may divide the theater into AD regions and appoint region commanders.

Air defense weapons in a theater of operations are controlled by one authority, the area air defense commander (normally

The region air defense commander is delegated full authority for air defense operations within his region. He also exercises control by publishing rules and procedures. Some of these rules, such as weapons control statuses, change frequently and are ordered into effect in specific areas at specific times. Intermediate commanders, to include supported maneuver commanders, may make these rules more restrictive, if the

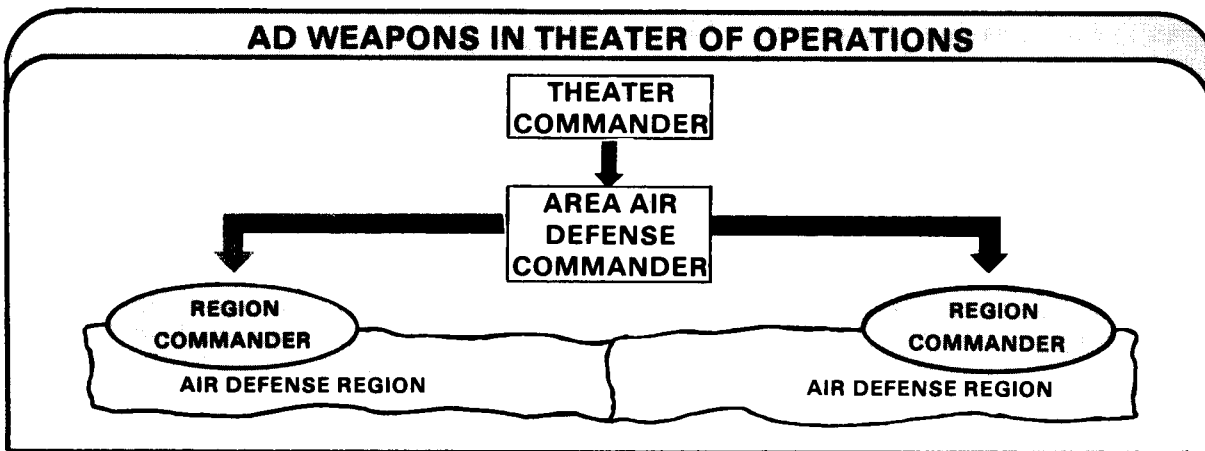

tactical situation warrants, but may not make them less restrictive than those

imposed by the region air defense commander.

COMMAND AND CONTROL OF THE STINGER PLATOON

Command and control of the Stinger platoon is accomplished by the platoon leader from his headquarters element. Command is exercised through the platoon leader and the section chiefs within the platoon. The headquarters element has radio equipment for control of the sections, for communications within the supported unit's command net, and for receipt of early warning information from the ADA battalion and/or supported brigade. Any changes in weapons control status, early warning, operating frequencies, call signs, ground security situation, IFF codes, etc., are transmitted immediately to the sections. The platoon headquarters monitors the personnel and equipment status of all sections by radio.

When the Stinger platoon is tactically employed as an element of a SHORAD firing battery, the Stinger platoon leader locates his headquarters element within or near the firing battery command post (CP). In this situation, the Stinger platoon leader assigns tactical missions to sections as directed by the battery commander.

When the Stinger platoon is tactically employed as the sole air defense organization supporting a maneuver force, the Stinger platoon leader locates his headquarters element within or near the CP of the supported unit. In this situation, the Stinger platoon leader responds to air defense requirements directly from the supported unit commander. He assigns tactical missions to his sections to provide air defense for the supported unit's priority assets.

The tactical situation may require that a Stinger platoon be employed with a SHORAD platoon. In this situation, the specific command relationship between the platoon leaders will be established by the SHORAD battalion or battery commander.

Normally, the Stinger section is the lowest element to be separately tasked or deployed. It is under the direct command of

the Stinger section chief. The Stinger section chief exercises command and control of his Stinger teams primarily through use of detailed TSOP. This procedural method of command and control is used because the teams are usually located long distances from the section headquarters element. Therefore, direct and personal supervision of each team is not normally possible. A tactical radio net provides a link between the section chief and his teams. Over this net, the section chief maneuvers his teams and provides positive control as needed. He modifies their state of readiness by relaying the air defense warning and weapons control statuses. Each section headquarters has radio communications with its platoon headquarters, the supported unit, and its firing teams. Early warning is received via voice radio and the target alert data display set.

★ The section chief may have to locate at some point between the teams and TOC. To effectively control the teams, the section headquarters element must be in communications with the Stinger teams. In the case where the Stinger section headquarters has lost contact with Stinger elements, the headquarters element must relocate to reestablish radio contact.

★ The Stinger section headquarters must always maintain communications with its teams and liaison with the maneuver battalion.

When appropriate, platoons or sections may be attached to the supported unit for a specific period. When so attached, command (to include administration and logistics) becomes the responsibility of the commander to whom attached. Air defense rules of engagement, weapons control statuses, and fire control orders which apply to the division area continue to be binding on attached Stinger elements. The local commander may make these measures more restrictive, but may not make them less restrictive.

COMMAND AND CONTROL PROCEDURES

Control of the fires of Stinger weapons is based on the fact that the elapsed time from target detection until target flyover is measured in seconds. Also, Stinger weapons are manned and fired by teams. Each team is individually positioned and is separated from all other teams supporting the same force. To be timely, the firing decision must be accomplished at the team position by the team chief. Authority to engage must be delegated to the team chief. Therefore, to control fires of their teams, Stinger leaders must insure that each team member has all the information and instructions necessary to make a correct engagement decision.

Control is exercised through air defense rules of engagement (ROE) which are directives that delineate the circumstances under which Stinger weapons can fire at an aircraft. Rules of engagement are established by the region/area air defense commander and are provided to the lowest necessary level by inclusion in the tactical SOP of each unit having an air defense mission or capability. The tactical SOP may include any or all of the following:

HOSTILE CRITERIA

Normally, the responsibility for target identification rests with the team chief. The exact criteria in use may vary with the tactical situation, from command to command, and in terms of time and space. Unit SOPs may classify those aircraft that are:

- **Attacking friendly elements.** Any aircraft actively attacking the team or defended unit or installations may be identified as hostile. The right of self-defense is never denied.
- **Performing any of the following acts over friendly troops or territory without prior coordination.**
 - Discharging smoke or spray.
 - Discharging parachutists or unloading troops in excess of normal aircraft crew.

- Engaging in mine-laying operations.
- Making unauthorized or improper entry into an area designated as restricted or prohibited. Care should be exercised in applying this criterion. This is necessary to avoid engaging a friendly aircraft that has been damaged and is returning to the rear of our lines. Also, it may have inadvertently strayed into the restricted area due to a navigational error.
- ★ Operating at prohibited speeds, altitudes, or in prohibited directions. The team chief must be able to apply this criteria if it comes to him in the form of early warning.
- ★ Bearing the military markings or having the configuration of an aircraft employed by a known enemy nation. This is the criterion most likely to be used by the Stinger team chief and probably the most difficult to apply. Application of this criterion must be based on visual inspection of the aircraft. Since aircraft markings are not usually visible at long ranges, most identifications must be based on recognition of the physical features of the aircraft. To eliminate any element of doubt, the team chief must be capable of recognizing friendly as well as enemy aircraft. (For additional discussion of aircraft recognition, refer to FM 44-30 and STANAG 2129.)

★ To aid in identification (ID), the Stinger weapon has been equipped with an IFF unit. The gunner initiates the IFF sequence by pressing the IFF INTERROGATE switch on the gripstock assembly. Once the gunner issues a challenge, the rest of the sequence is automatic. Aircraft with Mark X or Mark XII transponders automatically decode only if the interrogator is programmed with Mode 4 and Mode 3. Mode 3 is built into the interrogator; however, if during programming the Mode 4 only position is used, Mode 3 (Mark X) will not be challenged until the two or four days of Mode 4 coded have expired. The aircraft's transponder then prepares and sends

a coded reply. The reply is received by the Stinger antenna and is routed to the interrogator for decoding. The interrogator converts the reply into an audible tone which is then routed via the interconnecting cable to the gunner as a friendly tone. If the aircraft's transponder sends an incorrect reply to the IFF challenge, the reply is processed by the IFF system into an *unknown* tone. Additionally, aircraft not equipped with the transponders will not reply to the challenge, and this is also interpreted into an unknown tone. The gunner hears the friendly or unknown tone in his right earphone immediately after challenging the aircraft.

★ Positive IFF Mode 4 responses indicate a "true friend." Local tactical directives will specify whether Mode 3 returns are to be considered a possible friend. All other aircraft (those providing no IFF response) are given a

tentative ID of "unknown." This aids the Stinger team in identifying most friendly aircraft; however, the IFF unit does not provide positive ID of all friendly aircraft. Electronic malfunction or physical damage may prevent the interrogator or transponder from working properly. This is the reason that, given a tentative ID by IFF, the Stinger team normally must accomplish positive ID by visual recognition. An absence of an IFF return (Stinger IFF subsystem malfunction) will require the team chief to visually identify the aircraft. Engagement based solely on an unknown IFF return is permissible only under certain specified rules of engagement.

★ Interrogator programming is explained in TM 9-1425-429-12. The tones are described in FM 44-18-1. The mode, tone or symbolic response, and the team actions for Stinger in each of the weapons control statuses are shown in the following illustration.

★ IFF REPLIES AND WEAPONS CONTROL STATUSES			
IFF TONE	WEAPONS CONTROL STATUS		
	WEAPONS HOLD	WEAPONS TIGHT	WEAPONS FREE
MODE 4 TRUE FRIEND (BEEP—BEEP)	REGARDLESS OF IFF TONE, TARGET IS DECLARED HOSTILE, AND ENGAGED IN SELF-DEFENSE ONLY.	TARGET IS FRIENDLY. FOCUS ATTENTION ON NEXT IMMEDIATE THREAT. IF NONE IS AVAILABLE, RESUME TRACK ON TARGET TO CONFIRM FRIENDLY STATUS.	
MODE 3 POSSIBLE FRIEND (BEEEEEEEP)		TARGET IS POSSIBLE FRIEND. IF TARGET IS THE MOST IMMEDIATE THREAT, IT MUST BE TRACKED AND VISUALLY IDENTIFIED. IF TARGET IS NOT THE IMMEDIATE THREAT, STOP TRACKING AND FOCUS ATTENTION ON NEXT IMMEDIATE THREAT.	
UNKNOWN (BEEP, BEEP, BEEP, BEEP)		TARGET IS UNKNOWN. TRACK AND VISUALLY IDENTIFY.	TARGET IS UNKNOWN. ENGAGE.*
SELF-TEST FAIL (NO TONE)		VISUALLY IDENTIFY TARGET. ENGAGE ONLY THOSE AIRCRAFT POSITIVELY IDENTIFIED AS HOSTILE.	VISUALLY IDENTIFY TARGET. ENGAGE ONLY THOSE AIRCRAFT NOT POSITIVELY IDENTIFIED AS FRIENDLY.

*Note: Stinger gunners may *not* be allowed to engage an unknown target in WEAPONS FREE based solely on an IFF decision, if constrained by local directives/SOPs. Air defense commanders at every level must insure appropriate authorities understand the impact of such policies on the use of STINGER.

WEAPONS CONTROL STATUSES

Weapons control statuses are conditions which describe the relative tightness with which the fires of AD systems are managed. This degree or extent of control varies, depending on the relative priorities of two needs—

- The need to provide for the protection of friendly aircraft.
- The need to maintain a high level of air defense for a specific tactical situation.

The weapons control status is imposed by the area air defense commander; however,

other commanders (corps, division, maneuver brigade, or maneuver battalion) have the authority to impose a more restrictive weapons control status within their respective areas of operation for assigned, attached, or organic ADA weapons. Weapons control statuses may be varied to apply only to certain aircraft for specified time periods. For example, the status “Weapons Free for aircraft heading westbound; Weapons Tight for all other aircraft” is not unusual. Weapons control is normally described as a status (condition).

WEAPON CONTROL STATUSES	
TERM	DEFINITION
WEAPONS FREE	FIRE AT ANY AIRCRAFT WHICH IS NOT POSITIVELY IDENTIFIED AS FRIENDLY. (THIS IS THE LEAST RESTRICTIVE STATUS.)
WEAPONS TIGHT	FIRE ONLY AT AIRCRAFT WHICH ARE POSITIVELY IDENTIFIED AS HOSTILE.
WEAPONS HOLD	DO NOT FIRE EXCEPT IN SELF-DEFENSE. (THIS IS THE MOST RESTRICTIVE STATUS.)

RIGHT OF SELF-DEFENSE

Rules of engagement do not prohibit a unit or air defense weapon from shooting at

an aircraft that is attacking it — *the right of self-defense is never denied.*

FIRE CONTROL ORDERS

Fire control orders are commands which are used to control AD engagements on a case-by-case basis, regardless of the prevailing weapons control status.

Fire control orders are normally issued by the immediate ADA commander (team chief) for the purpose of fire distribution or for safety.

FIRE CONTROL ORDERS	
ORDER	ACTION
ENGAGE	TAKE TACTICAL ACTION AGAINST THE SPECIFIC TARGET INDICATED. (THIS ORDER CANCELS ANY PREVIOUS FIRE CONTROL ORDER.)
CEASE ENGAGEMENT	STOP TACTICAL ACTION AGAINST THE SPECIFIC TARGET NOW BEING ENGAGED. PREPARE TO ENGAGE ANOTHER TARGET.
HOLD FIRE	AN EMERGENCY ORDER USED TO STOP ALL TACTICAL ACTION BY A PARTICULAR FIRE UNIT OR AGAINST A PARTICULAR TARGET, E.G., TO PROTECT SPECIFIC FRIENDLY AIRCRAFT.

LOSS OF COMMUNICATIONS

If communications break down for any reason, the section/team must take immediate action to reestablish communications. These actions will be listed in the TSOP and may be similar to the following if, at the time communications are lost, the weapons control status was:

Weapons Tight. The section/team will remain in weapons tight.

Weapons Hold. If a time limit was placed on the weapons holds restriction, the

section/team will maintain weapons hold for this time limit and then revert to weapons tight. If no time limit was established, the section/team will maintain weapons hold for 30 minutes and then revert to weapons tight.

Weapons Free. If a time limit was established, the same rule applies as in weapons hold. If no time limit was established, the section/team will immediately revert to weapons tight.

WARNING PROCEDURES AND ALERT STATUSES

To prepare units for enemy air attack, air defense warnings (ADW) may be broadcast by ADA battalion, TOC, or the division airspace management element (DAME). These warnings provide the platoon leader general information of the air threat.

States of alert can be used by the section chief to vary the level of preparedness of his teams. These states of alert should be defined in the local TSOP and may be based on the ADWs. (See example.)

AIR DEFENSE WARNINGS

RED — ATTACK IS IMMINENT OR IN PROGRESS.

YELLOW — ATTACK IS PROBABLE.

WHITE — ATTACK IS NOT PROBABLE.

EXAMPLE

RED - BATTLE STATIONS
ALL TEAMS PREPARE TO ENGAGE AIRCRAFT.

YELLOW - STANDBY
DESIGNATED TEAMS PERFORM AIR WATCH
AND BE PREPARED TO ENGAGE AIRCRAFT.
ALL TEAMS BE PREPARED TO ENGAGE
AIRCRAFT WITHIN A SPECIFIED TIME.

WHITE - STAND-DOWN
TEAMS ARE TEMPORARILY RELEASED FROM
THE AIR DEFENSE MISSION, BUT MUST BE
ABLE TO ATTAIN STANDBY STATUS WITHIN A
SPECIFIED TIME PERIOD.

SUPPLEMENTAL FIRE CONTROL MEASURES

Supplemental fire control measures are procedural management measures intended to delineate or modify hostile criteria, delegate identification authority, or serve strictly as aids in fire distribution or airspace control. The fire supplemental fire control measures are air defense operations area (ADOA), weapons engagement zones (WEZ), high density airspace control zones, temporary airspace restriction measures, and sectors of fire and primary target lines (PTL).

Air Defense Operations Area. An area and the airspace above it within which procedures are established to minimize mutual interference between AD and other operations. It can include designation of one or more of the following:

- Air defense action area. An area and the airspace above it in which friendly aircraft or ADA weapons are normally given precedence in operations except under specified conditions. This type of ADOA is primarily used to minimize mutual interference between friendly aircraft and ADA weapon systems. Air defense action areas which have been prioritized for ADA weapons are similar to restricted operations areas for aircraft, except that air defense action areas are normally in effect for a longer period of time.
- Air defense area. A specifically defined airspace for which air defense must be planned and provided. This type of ADOA is primarily used for airspace control, but may also be used to define any area within which ADA units are operating.
- Air defense identification zone (ADIZ). Airspace of defined dimensions within which the ready identification, location, and control of airborne vehicles are required. This type of ADOA is normally used only for airspace control. Areas within an ADIZ will normally be characterized by extremely stringent hostile criteria and weapons control statuses.

Weapons Engagement Zone (WEZ). A volume of defined airspace within which a

specific type of AD weapon is preferred for use in an engagement. Use of WEZ does not preclude engagement of high-priority targets by more than one type of weapon system if centralized control of each weapon system involved is available. The activation of a WEZ can be used to delegate identification authority to respective fire units by specifying different (usually more stringent) hostile criteria within the WEZ than outside the WEZ. Commonly used WEZs include —

- Fighter engagement zone (FEZ). FEZs are normally established only in those areas where no effective surface-to-air capability is deployed.
- High-altitude missile engagement zone (HIMEZ). Normally applied to long-range surface-to-air missiles (SAM), a HIMEZ limits the volume of airspace within which these weapons can conduct engagements without specific direction from the authority establishing the WEZ.
- Low-altitude missile engagement zone (LOMEZ). This volume of airspace establishes control over engagements by low-to-medium altitude SAMs (to include Hawk). The same considerations pertinent to the HIMEZ and FEZ apply. Subject to weapon system capabilities, the LOMEZ may extend beyond the forward line of own troops (FLOT).
- Short-range air defense engagement zone (SHORADEZ). Areas of SHORAD deployment may fall within a HIMEZ or LOMEZ. It is also possible that some areas may be solely defended by SHORAD assets. A SHORADEZ can be established to define the airspace within which such assets will operate. Because centralized control over SHORAD weapons may not be possible, these areas must be clearly defined and promulgated so that friendly aircraft can avoid them.

The example shows WEZ geographic and altitude boundaries for a type AD region. Each WEZ gives particular types of weapons more freedom of action in the protection of

rear area assets. Thus, within an activated HIMEZ, Hercules and Patriot would be placed in a less restrictive WCS. The same applies to Hawk with regard to the LOMEZ. Established well forward, the LOMEZ gives Hawk greater freedom of action and maximizes its effectiveness. The SHORADEZ performs the same function for short-range ADA organic to committed divisions. The FEZ covers the same region, but over ADA, WEZ areas descend only to the upper limits of HIMEZ, LOMEZ, and SHORADEZ. Since fighters and ADA systems each have their own operating areas, the possibility of friendly aircraft engagement is minimized.

WEZs are established by local operation plan, but are activated and modified by message.

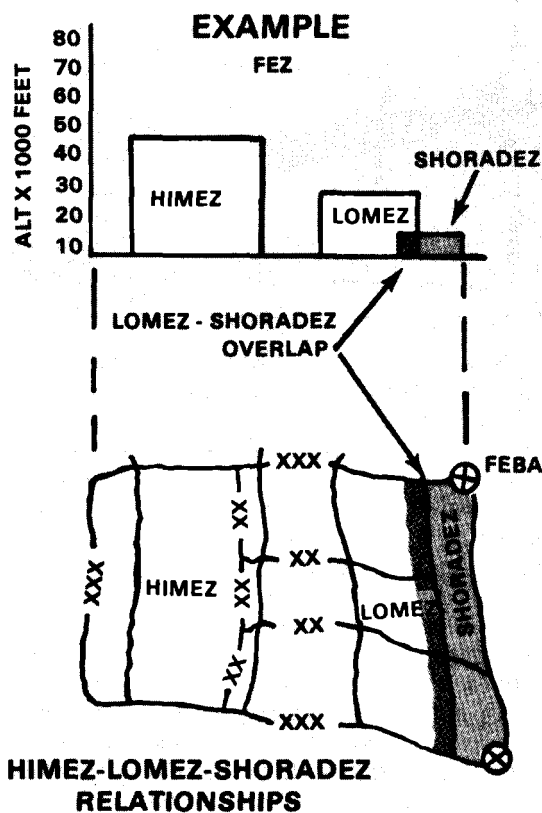

High-density Airspace Control Zone (HIDACZ). A HIDACZ is an airspace of defined dimension in which there is a concentrated employment of numerous and varied airspace users. These can include aircraft, artillery/mortar/naval gunfire, local AD weapons, and surface-to-surface missiles. HIDACZ is established by the area air defense commander upon request of local maneuver commanders. HIDACZ is established when the level and intensity of airspace operations dictate the need for special airspace control measures. The number of such zones will vary depending on the combat situation and/or the complexities of air traffic control in conjunction with fire support coordination. The establishment of a HIDACZ normally increases temporary restrictions on ADA fires within the volume of defined airspace.

Temporary Airspace Restriction Measures. Temporary airspace restrictions can be imposed on segments of airspace of defined dimensions in response to specific situations and requirements. These can include search and rescue (SAR) operations, air refueling areas, high density airspace control zone, concentrated interdiction areas, and areas declared AD WEAPONS FREE. These restrictions include —

- Identification of the airspace user being restricted.
- Period, area, altitude, and height of restriction.
- Procedures for cancellation or modification of the restriction in event of communication loss.

The three common temporary airspace restrictions are —

- Restricted operations areas.
- Minimum risk routes (MRR)/low-level transit routes (LLTR).
- Standard-use Army aircraft routes.

Restricted operations areas are airspaces of defined dimensions within which the operation of one or more airspace users is

restricted, generally for a short time. These areas are established by the airspace control authority (ACA) in response to the requests of ground force commanders.

Restricted operations areas for aircraft can be established to maximize ADA effectiveness. In such cases, the normal ADA weapons control status will be Weapons Free.

EXAMPLE

RESTRICTED OPERATIONS AREAS FOR AIRCRAFT

WEAPONS FREE: FOR DESIGNATED AIRSPACE AROUND A KEY CROSSING SITE DURING RIVER-CROSSING OPERATIONS. WEAPONS FREE AREA INFORMATION (E.G., SIZE, TIME-RESTRICTION IS IN EFFECT) WOULD BE PROVIDED TO AIR FORCE AND ARMY AVIATION UNITS AS WELL AS AIR DEFENSE UNITS. KEEPING FRIENDLY AIRCRAFT AWAY FROM THE WEAPONS FREE AREA WOULD ALLOW ADA MAXIMUM FREEDOM TO ENGAGE HOSTILE AIRCRAFT.

Restricted operations area for ADA can be established to maximize aircraft effectiveness. In such cases, the normal ADA weapons control status will be Weapons Hold.

EXAMPLE

RESTRICTED OPERATIONS AREA FOR ADA

WEAPONS TIGHT: EXCEPT WEAPONS HOLD, 0600-0645, FOR HELICOPTERS WESTBOUND OVER 1ST BRIGADE AREA. THIS CONTROL STATEMENT PROVIDES SPECIAL PROTECTION FOR FRIENDLY HELICOPTERS SCHEDULED TO PASS WESTWARD THROUGH THE 1ST BRIGADE AREA AT INDICATED TIME.

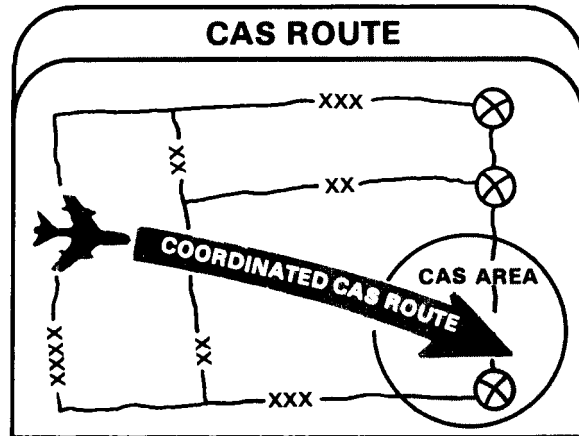
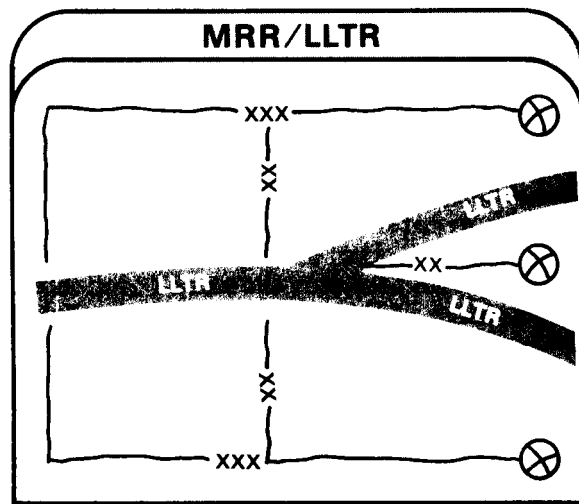

Minimum risk route/low-level transit route (MRR/LLTR): A temporary corridor of defined dimensions passing in either direction through ADA defenses, a high density airspace control zone, or through a restricted operations area. It is designed to reduce risk to high-speed aircraft transiting the tactical operations area at low altitudes. MRRs/LLTRs will normally be confined to that airspace in which ADA must be maintained at Weapons Free. Such circumstances will exist where there is inadequate timely control capability to permit a more flexible method of air defense. However, aircraft transiting the tactical operations area are not required to use activated MRRs/LLTRs. In such cases where aircraft

do not use MRRs/LLTRs, it is recognized that established AD procedures will apply. Also, close air support (CAS) aircraft will not normally use MRRs/LLTRs. This is because such sorties are flown in response to Army requests and are coordinated by the forward air controller (FAC) or other tactical air control system elements with the supported Army unit.

The weapons control status for ADA fire units whose engagement ranges intercept an activated MRR/LLTR remains at Weapons Tight for that part of the route. Should it become necessary to change to Weapons Free, that particular route will be closed by the commander who established it.

Standard-use Army aircraft routes are temporary corridors of defined dimensions

passing in either direction through the rear operations area to designated points in the tactical operations area. These routes will terminate in relatively secure areas. Two points are important for ADA in connection with standard-use routes —

Since high-speed aircraft avoid standard-use routes, ADA hostile criteria may include provisions that high-speed aircraft within these routes can be declared hostile.

The weapons control status of ADA fire units whose engagement ranges intercept an activated standard-use route remains at Weapons Tight for that part of the route. Should it become necessary to change to Weapons Free, that particular route will be closed by the commander who established it.

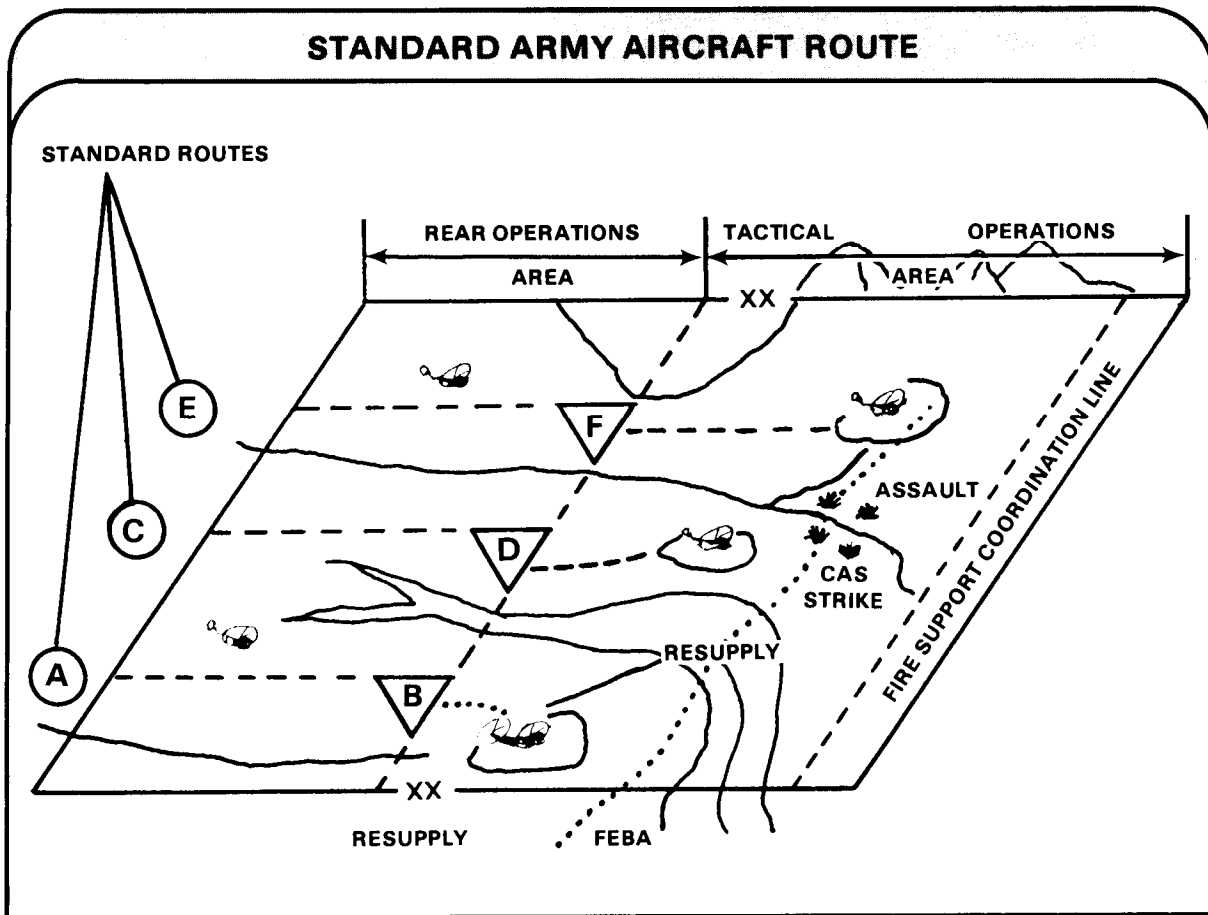

Sectors of Fire and Primary Target Lines.

Stinger teams normally use sectors of fire and primary target lines to insure that all aircraft attacking the defended asset are engaged. Normally, if a single aircraft is attacking the asset, all air defense must be prepared to defend against multiple targets attacking from different directions. Also, these control measures provide sectors of fire or primary target lines applicable to each weapon defending an asset. Each Stinger team normally concentrates its fires on the most threatening aircraft within its assigned sector or closest to its primary target line. Typical control measures are—

- Primary sector of fire (PSF). A sector defined by azimuth boundaries within which the team will focus its primary attention (both searching and firing).
- Primary target line. An azimuth along which the team will focus its primary attention.

The assignment of a PSF or PTL does not restrict the team to looking only at the sector or line. Rather, it means that, given two targets that are equal threats, the team will fire on the target within the PSF or closest to the PTL.

Sectors of fire are normally designated at section headquarters after review of fire unit coverage diagrams. Overlapping coverage and distance between teams is discussed later in this manual. The section chief assigns primary target lines as shown in the example.

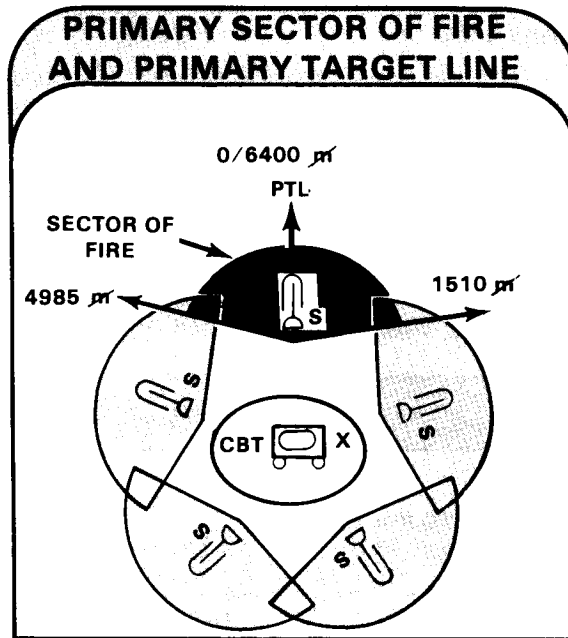

CHAPTER 4 Communications

The ability of a Stinger platoon/section leader to react to rapidly changing conditions on the modern battlefield is dependent on efficient and reliable communications. Radio and wire communications are provided Stinger units to facilitate command and control. Because the Stinger teams are widely dispersed, and subject to frequent and rapid moves, radio is the prime means of communications during tactical operations.

Threat forces know the key to success in combat is an effective communications system. The Threat will use electronic warfare (EW) to disrupt as many command, control, and weapons communications systems as possible. Their major electronic offensive will happen during the first minutes of the first battle. Therefore, communications on the modern battlefield may be considerably degraded or nonexistent.

★ The improved early warning Manual SHORAD Control System (MSCS) ties in the air defense coordination net and the early warning broadcast nets which are used by Stinger units. (See FMs 44-3, 44-11, and 44-18-1 for further details.)

STINGER RADIO EQUIPMENT

Stinger platoons use only one type of AM radio — AN/PRC-104 (1) for receipt of early warning. Stinger platoons use FM radios for battery and platoon command nets, and for supported unit nets. Stinger platoons within armored, infantry, mechanized (AIM) infantry divisions and separate brigades are authorized the AN/VRC-47 (2) radio and AN/VRC-48 (3) radio. Within these units, Stinger

teams are authorized an AN/VRC-47 (2) radio. Stinger platoons within air cavalry combat brigades and armored cavalry regiments are also equipped with these radios. Stinger platoons with airborne divisions are authorized the AN/VRC-48 (3) and AN/ GRC-160 (4), radios. Stinger platoons within air assault divisions are authorized the AN/VRC-48 3 and AN/PRC-77 (5) radios.

CONTENTS			
	PAGE		PAGE
Stinger Radio Equipment	4-1	Wire Communications	4-8
Radio Nets	4-4	Backup Communications	4-9
FAAR/TADDS	4-7	Using the CEOI	4-10

(1)

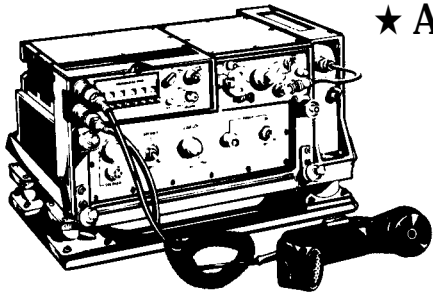

★ AN/GRC-213

AM RADIO SET AN/GRC-213 IS USED TO MONITOR EARLY WARNING INFORMATION. IT IS AUTHORIZED FOR THE STINGER PLATOON AND SECTION HEADQUARTERS. PART OF THE AN/GRC-213 CAN BE RAPIDLY CONVERTED TO A MANPACK (AN/PRC-104A).

AN/VRC-47, and AN/VRC-48

(2)

AN/VRC-47

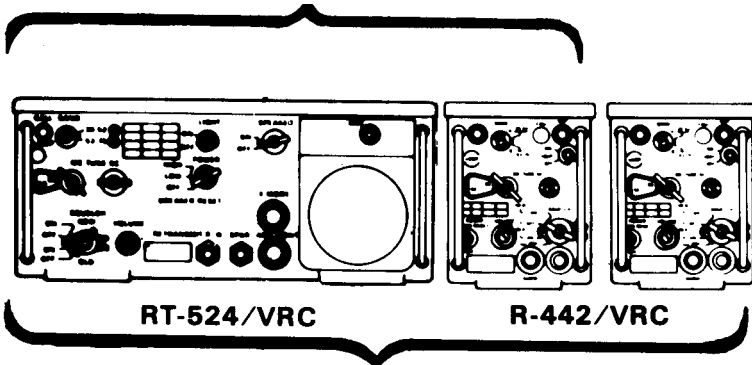

THE AN/VRC-47 COMBINES THE RT-524/VRC WITH ONE ADDITIONAL RECEIVER — THE R-442/VRC. THIS RADIO SET MONITORS ONE NET WHILE THE RECEIVER-TRANSMITTER OPERATES IN ANOTHER.

THE AN/VRC-48 RADIO USES THE RT-524/VRC RECEIVER-TRANSMITTER. THE AN/VRC-48 COMBINES THE RT-524 WITH TWO ADDITIONAL RECEIVERS (R-442/VRC AUXILIARY RECEIVER). THIS RADIO SET OPERATES IN THREE RADIO NETS AT THE SAME TIME. THE RADIO RECEIVERS MONITOR TWO SEPARATE NETS WHILE THE RECEIVER-TRANSMITTER OPERATES IN A THIRD.

(3)

AN/VRC-48

AN/GRA-39

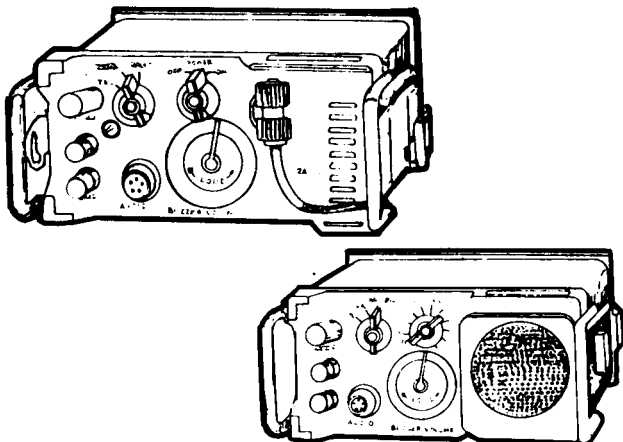

BOTH AN/VRC-47 AND -48 RADIOS CAN BE REMOTED USING THE AN/GRA-39 RADIO SET CONTROL GROUP. THIS BATTERY-OPERATED REMOTE CONTROL SYSTEM CONSISTS OF A LOCAL CONTROL UNIT AND A REMOTE CONTROL UNIT. WHEN CONNECTED TO THE RADIO WITH FIELD WIRE, THE AN/GRA-39B CAN BE OPERATED FROM A DISTANCE OF UP TO 3.2 KM (2 MI). BY USING THE REMOTE CONTROL UNIT, STINGER PERSONNEL CAN TRANSMIT AND RECEIVE COMMUNICATIONS INFORMATION WHILE POSITIONED AWAY FROM THEIR VEHICLES.

AN/GRC-160

THE AN/GRC-160 INCORPORATES THE COMPONENTS AND OPERATIONAL CHARACTERISTICS OF THE PORTABLE FM RADIO SET AN/PRC-77 AND THE VEHICULAR RADIO SET AN/VRC-64. THE AN/GRC-160 WILL NET WITH THE AN/VRC-12 SERIES. IT IS, HOWEVER, A SMALLER SET AND IS DESIGNED TO OPERATE OVER SHORTER DISTANCES. THIS RADIO SET CAN BE USED IN REMOTE OPERATION.

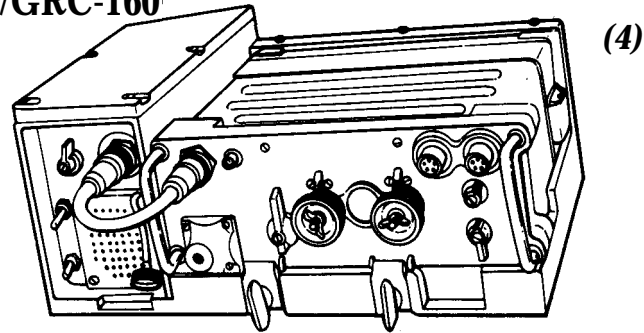

(4)

AN/PRC-77

RADIO SET AN/PRC-77 IS A SHORT-RANGE, LIGHTWEIGHT, FULLY TRANSISTORIZED RADIO SET THAT CAN BE EITHER VEHICLE-MOUNTED OR MAN-CARRIED. IT CAN BE OPERATED WITH SPEECH SECURITY EQUIPMENT.

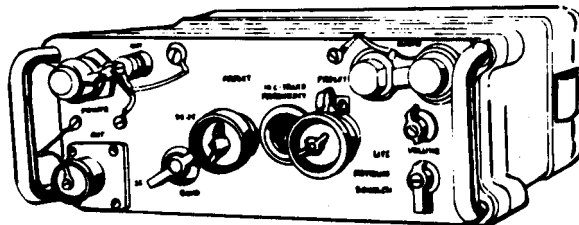

(5)

★STINGER PLATOON RADIOS & CHARACTERISTICS

RADIO	TECHNICAL CHARACTERISTICS				REFERENCES
	TYPE OF SERVICE	FREQUENCY RANGE	PLANNING RANGE	REMOTE OPERATION	
① AN/GRC-213	SINGLE CHANNEL VOICE	2.0 TO 29.9 MHz			TO BE DETERMINED
② + ③ AN/VRC-48, 47	SINGLE CHANNEL VOICE	BAND A 30 TO 52.95 MHz BAND B 53 TO 75.95 MHz	LOW 8 KM HIGH 41 KM	USES AN AN/GRA-39B	TM 11-5820-401-12 TC 11-4
④ + ⑤ AN/GRC-160 (AN/PRC-77)	SINGLE CHANNEL VOICE	LOW BAND 30 TO 52.95 MHz HIGH BAND 53 TO 75.95 MHz	8 KM	AN/GRC-160 CAN BE REMOTED	TM 11-5820-498-12
RADIO SET CONTROL GROUP AN/GRA-39	SINGLE CHANNEL VOICE	300 TO 3500 MHz	3.2 KM USING FIELD WIRE		FM 24-24 TM 11-5820-477-12

RADIO NETS

PLATOON COMMAND NET

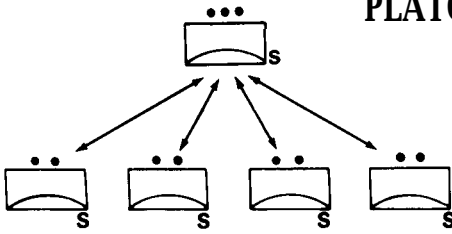

THE STINGER PLATOON COMMAND NET IS USED TO PROVIDE COMMAND AND CONTROL OF STINGER. THIS IS A TWO-WAY NET BETWEEN THE PLATOON AND SECTION HEADQUARTERS.

SECTION COMMAND NET

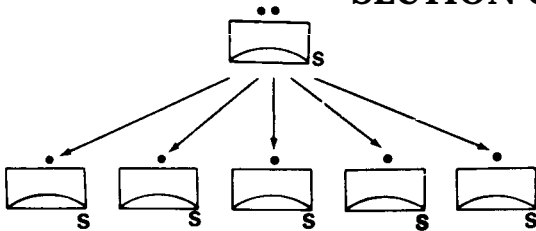

STINGER SECTION COMMAND NET IS USED TO PROVIDE COMMAND AND CONTROL OF STINGER TEAMS. THIS IS A TWO-WAY NET BETWEEN THE STINGER SECTION HEADQUARTERS AND THE STINGER TEAMS.

The relationship of the Stinger nets and equipment within a sample platoon in an AIM division is shown below. No attempt is

made to show communications links or equipment above platoon level.

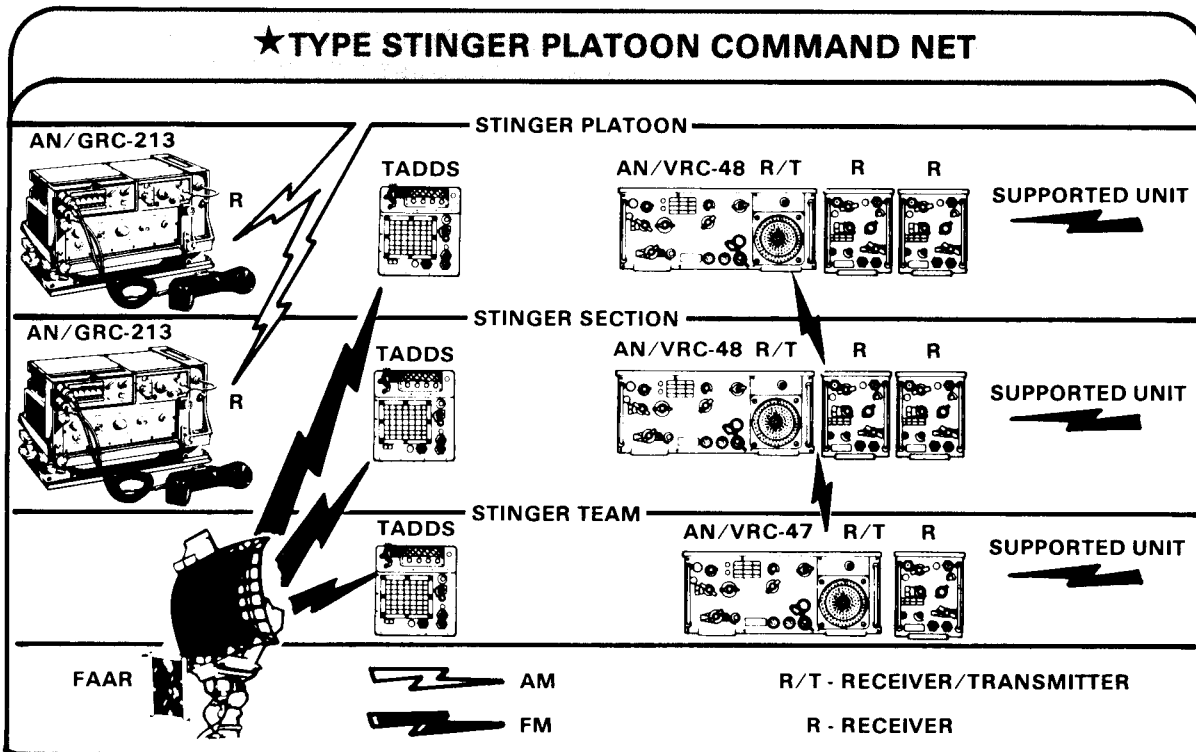

Normally, the Stinger platoon leader will place the receiver/transmitter unit of the AN/VRC-48 on the frequency of the platoon command net. This allows two-way communications between the platoon headquarters and the sections. The platoon may be in support of a maneuver unit. In this case, one receiver of the AN/VRC-48 is tuned to the frequency of the supported unit's command net. If not in support of a maneuver unit, this receiver can be used to monitor other air defense units. These units operate with or in the vicinity of the platoon. The second receiver of the AN/VRC-48 is normally used to monitor the C/V battery command net. The platoon leader can switch frequencies to transmit to monitored units as necessary.

★ The TADDS (FM) and the AN/GRC-213 (AM) radios are both used to monitor early warning information. The TADDS receives this information directly from a FAAR. The

AN/GRC-213 monitors early warning information which is generated from either a HIMAD battalion or the nearest air defense command and control facility.

When the platoon leader uses his equipment in this manner, he is receiving a great deal of data. The table shows what data are transmitted over the various nets.

★ The Stinger section headquarters has similar communications capabilities as the platoon headquarters. The Stinger section headquarters is authorized an AN/VRC-48 radio, a TADDS, and an AN/GRC-213 AM radio set. This equipment gives the section chief the capabilities to receive early warning information from the early warning net and FAAR. Also, he can monitor two frequencies while receiving and transmitting on a third.

★ TRANSMITTED DATA	
NET	INFORMATION
EARLY WARNING NET (AM)	EARLY WARNING, COMMAND AND CONTROL INFORMATION.
PLATOON COMMAND NET (FM)	WARNING ORDERS. MOVEMENT ORDERS. COMMAND AND CONTROL INFORMATION. EARLY WARNING INFORMATION. ANY OTHER INFORMATION ESSENTIAL FOR SECTION OPERATIONS.
SUPPORTED UNIT COMMAND NET (FM)	ADMINISTRATIVE AND LOGISTICS INFORMATION. RESTRICTIVE CONTROLS THE SUPPORTED UNIT COMMANDER WISHES TO PLACE ON THE PLATOON. ANY OTHER INFORMATION ESSENTIAL TO COORDINATING AIR DEFENSE SUPPORT OF THAT UNIT.
C/V BATTERY COMMAND NET (FM)	EARLY WARNING, COMMAND AND CONTROL INFORMATION RECEIVED FROM THE DAME, DIVISION TACTICAL CP, OR THE AIR DEFENSE COORDINATION OFFICER. FAAR LOCATIONS. AIR INTELLIGENCE INFORMATION FROM THE BATTALION S2. INFORMATION ON C/V UNITS OPERATING IN THE VICINITY OF THE STINGER SECTION.
FAAR/TADDS LINK	APPROXIMATE TARGET LOCATION AND TENTATIVE IDENTIFICATION.

The Stinger section headquarters operates in the Stinger section command net. Normally, the Stinger section chief will place the receiver/transmitter unit of the AN/VRC-48 on the frequency of the section command net. This allows two-way communications between the section headquarters and the teams. If the section is

in support of a maneuver unit, one receiver of the AN/VRC-48 is tuned to the frequency of the supported unit's command net. The second receiver of the AN/VRC-48 is normally used to monitor the Stinger platoon command net. The section chief can switch frequencies to transmit to monitored units as necessary.

STINGER TEAM NETTING - AIM DIVISION

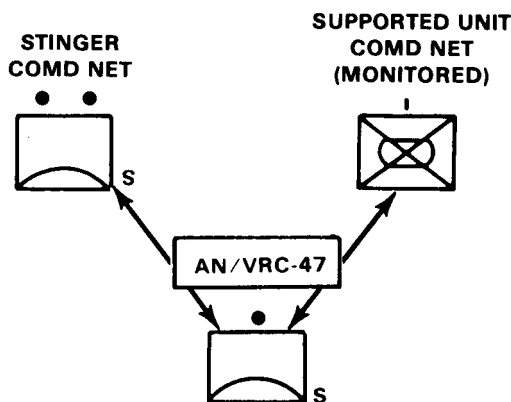

EACH STINGER TEAM IN AN ARMORED, INFANTRY, MECHANIZED (AIM) DIVISION, SEPARATE BRIGADE, AND ARMORED CAVALRY REGIMENT IS EQUIPPED WITH A TADDS AND AN AN/VRC-47 FM RADIO. THE TEAM CHIEF NORMALLY PLACES HIS RECEIVER/TRANSMITTER ON THE FREQUENCY OF THE SECTION COMMAND NET. THE AUXILIARY RECEIVER IS THEN USED TO MONITOR ANY OTHER FREQUENCY THE SECTION CHIEF SPECIFIES. THIS IS TRUE ONLY IF THE TEAM IS NOT SUPPORTING A MANEUVER UNIT. REMEMBER, HE CAN ONLY MONITOR ONE NET AT A TIME IN ADDITION TO HIS SECTION COMMAND NET. THE TADDS, OF COURSE, RECEIVES INFORMATION FROM A FAAR. THE STINGER TEAM-SUPPORTED UNIT RELATIONSHIP IS SHOWN.

STINGER TEAM NETTING - AIRBORNE

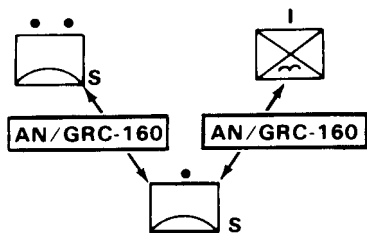

EACH STINGER TEAM IN AN AIRBORNE DIVISION IS EQUIPPED WITH TWO AN/GRC-160 RADIOS. ONE RADIO PROVIDES COMMUNICATIONS WITHIN THE SECTION COMMAND NET. THE OTHER RADIO PROVIDES COMMUNICATIONS WITHIN THE SUPPORTED UNIT COMMAND NET.

★ STINGER TEAM NETTING - AIR ASSAULT

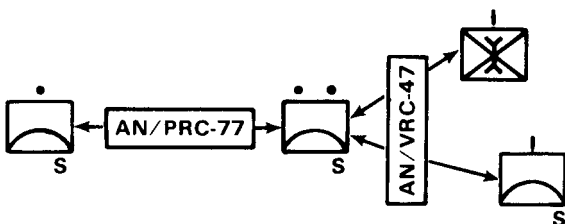

EACH STINGER TEAM IN AN AIR ASSAULT DIVISION IS EQUIPPED WITH ONE PRC-77 RADIO, WHICH PROVIDES COMMUNICATIONS WITHIN THE SECTION. THE STINGER SECTION HEADQUARTERS MONITORS THE SUPPORTED UNIT COMMAND NET AND SERVES AS THE RADIO LINK BETWEEN THE TEAMS AND THE SUPPORTED UNIT.

★ STINGER TEAM NETTING WITH VULCAN

WHEN VULCANS PROVIDE AIR DEFENSE OF A COMPANY TEAM ALSO SUPPORTED BY STINGER, THE VULCAN PLATOON LEADER, VULCAN SQUADS, AND STINGER TEAM(S) OPERATE IN THE VULCAN PLATOON NET. EARLY WARNING, CHANGES IN WEAPONS CONTROL STATUS, AD WARNINGS, ALERT STATUS, AND OTHER INFORMATION RECEIVED BY THE VULCAN PLATOON ARE REPEATED ON THE VULCAN PLATOON NET. WHEN REQUIRED, THE COMPANY TEAM COMMANDER AND THE STINGER SECTION CHIEF MAY PASS ORDERS AND INFORMATION TO THE STINGER TEAM THROUGH THE VULCAN PLATOON NET.

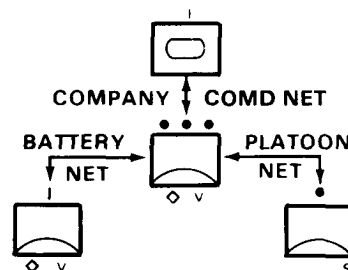

FAAR/TADDS

FAAR

The FAAR is a self-contained, pulse-doppler search radar system. Its mission is to provide EW in the form of general target location and tentative identification. The EW is provided to TADDS receivers located at Chaparral/Vulcan fire units, Stinger platoons, sections, and teams. The range of the FAAR is 20 kilometers.

The FAAR transmits information to the TADDS using an AN/VRC-46 FM radio. Since the AN/VRC-46 is an FM radio, line of sight is necessary between the FAAR and the TADDS.

★ Several FAARs will normally be operating in the division area. Each has a different address code. Also, each is assigned a different frequency in the Communications-Electronics Operations Instructions (CEOI). To get the location of the FAARs, the section chief usually obtains this information from the local C/V battalion tactical operation center.

Normally, the Stinger section chief will study the positions of the various FAARs in the division area. He will then determine which one will provide the best early warning coverage for his teams. He then must determine if line of sight can be achieved with the selected FAAR. If the teams cannot achieve line of sight, he must choose another

FAAR. FAAR positions may change during a battle. Therefore, the section chief must know where the FAARs are located at all times.

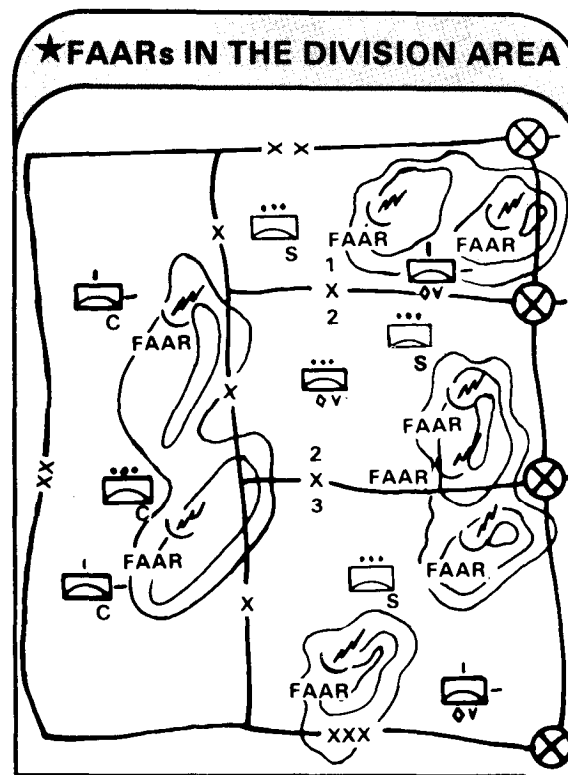

TADDS

The size of the sector a Stinger team must search affects the range at which aircraft can be detected. If an observer is warned of an approaching aircraft and has a narrow sector of search, his chances of detecting the target early are greatly improved.

Each Stinger team is authorized a target alert data display set (TADDS). The battery operated TADDS is a lightweight FM receiver used to obtain early warning, location, and tentative identification of aircraft detected by a FAAR belonging to the Chaparral/Vulcan battalion.

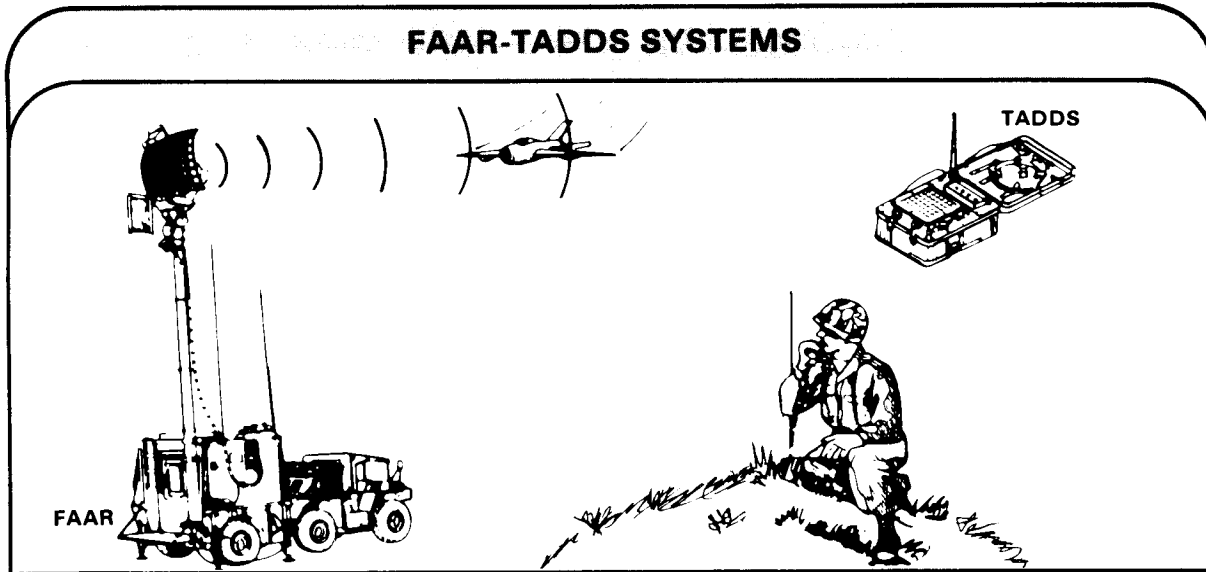

WIRE COMMUNICATIONS

Wire is one of the most dependable communications means. Wire is more secure than radio communications, but security of classified information is only insured when it is used over security approved wire systems. Wire communications are especially useful in defensive operations when movement is often limited and time is available for installation and maintenance. When the supported unit establishes its wire system, Stinger units can communicate by wire. Stinger wire communications means are limited. The Stinger units depend on the parent organization or supported unit to lay wire to them.

Stinger team positions may be

interconnected by wire for local communications in static situations or during listening or radio silence. This might be the situation where Stinger units are supporting a battalion task force.

Members of split Stinger teams also use wire to communicate over short distances. The gunner strings wire to another position, attaches the field telephone, and establishes communications with the team chief.

Two types of field telephones are used within the platoon. The TA-312/PT is used by both platoon and section headquarters, while the TA-1/PT is used at the team level.

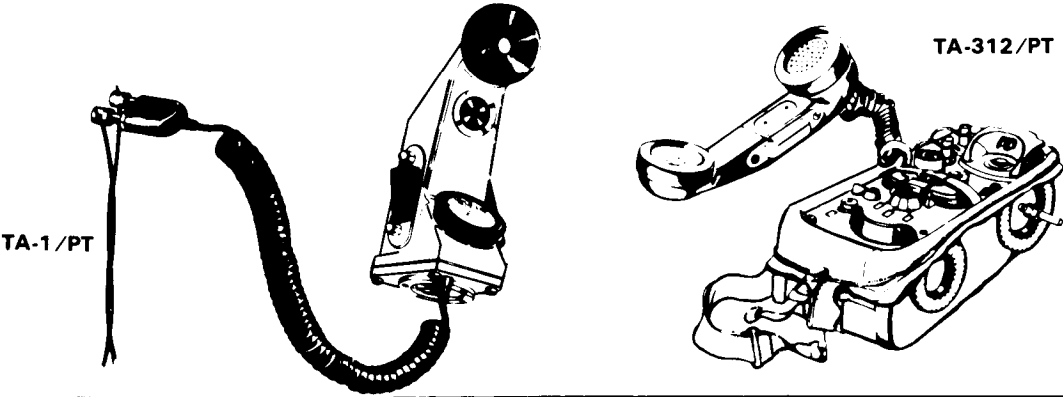
FIELD TELEPHONES		
		
TELEPHONE CHARACTERISTICS		
TYPE	TA-312/PT	TA-1/PT
TALKING AND SIGNALING RANGE.	22.4 KM (WET LINES) TO 38.4 KM (DRY LINES), USING WD-1/TT WIRE.	9.26 TO 16 KM USING WD-1/TT WIRE.
SIGNAL INDICATION.	AUDIBLE (ADJUSTABLE).	VISUAL OR AUDIOVISUAL.

REFERENCE TM 11-5805-201-12 AND TM 11-5805-243-12 FOR SPECIFIC INFORMATION CONCERNING THE OPERATION AND ORGANIZATIONAL MAINTENANCE.

BACKUP COMMUNICATIONS

The mobility required of a Stinger section in most cases dictates that radio be the primary means of communications. For sections in a static situation, wire can be used effectively as a backup. For sections on the move, however, wire is impractical.

The Stinger sections and teams need early warning and command and control information to accomplish their mission. Backup channels for this information already exist in the platoon's and section's normal communications setup. Use of alternate routing of information can be accomplished through the supported unit nets. For instance, a message could be routed over the supported unit net to a Stinger team whose radio has been damaged. The section

chief could send the message through the supported unit command net directly to the unit nearest the Stinger team. In the same case, if time and distance permit, the team could also lay wire to a nearby unit for temporary communications.

★ The AN/GRC-213 receiver gives the platoon leader and section chief the capability of getting early warning. The Stinger team does not have this capability. Therefore, any early warning from this source must be relayed to Stinger teams over the section command net. Since this type of information is time-essential, it could be outdated before the team receives it. This information must be verified.

VISUAL

★ Arm and hand signals may be used by the Stinger team members. They use these signals to communicate among themselves and with supported unit personnel. Arm and hand signals are useful when radio or wire is not available and battlefield noise does not permit use of voice commands. Arm and hand signals should be used only when absolutely necessary. Standard and special hand-and-arm signals are covered in FM 71-1. They are used to control small unit actions, recovery operations, and vehicle movements for the tank and mechanized infantry company team. Arm and hand signals for the communication of Stinger fire commands are shown in FM 44-18-1.

SOUND

Such simple devices as whistles, bugles, horns, sirens, bells, klaxons, voice amplifiers, and explosive devices are used for sound communications. Principal uses of sound communications are to attract attention, transmit prepared messages, and spread alarms. Sound signals are satisfactory only for short distances; range and reliability are greatly reduced by battle noise. Sound signals are open to enemy interception and imitation. Thus, they may be restricted for security reasons. To avoid misunderstanding, sound signals must be simple. Prearranged meanings for sound signals are normally included in the unit SOP and CEOI.

USING THE CEOI

Proper use of the CEOI is a major portion of operations security (OPSEC). The CEOI is perhaps the most abused document in the Army today. Often it is regarded as a document which interferes with communications

instead of aiding effective, secure communications. To be effective, all of the CEOI, not just parts of it, must be used in training. Operations security, including use of the CEOI, is discussed further in appendix B.

CHAPTER 5

Stinger Employment Principles and Guidelines

Stinger units are organized and equipped to accomplish the ADA mission within their system capabilities. The specific tactical mission assigned to a Stinger platoon will vary depending on the mission received by its higher headquarters and the current tactical situation.

This chapter describes the types of missions which can be assigned to a Stinger unit. It also describes how Stinger deployment may have to be changed based on changing priorities and how Stinger is organized to support the tactical plan. The chapter also shows how Stinger defenses are planned.

SECTION I

ORGANIZATION FOR COMBAT

Stinger's role is to provide air defense for forward combat elements against low-altitude hostile aircraft. Stinger defends high-priority maneuver and field artillery battalions in position, and also defends high-priority critical assets (e.g., command post, trains, ASP, and POL) for which no ADA guns or Chaparral are available. Stinger also complements ADA guns when priorities and the situation permit.

★CONTENTS	
	PAGE
<i>Section I Organization for Combat</i>	
Allocation of Forces	5-1
Organizing for Combat	5-2
Tactical Missions	5-2
Types of Air Defense	5-5
<i>Section II Air Defense Planning</i>	
Air Defense Employment Principles	5-5
Air Defense Artillery Employment Guidelines	5-6
Stinger Defense Design Requirements	5-7
<i>Section III Different Defense Considerations</i>	
Static Critical Asset Defense	5-10
Mobile Critical Asset Defense	5-13
Defense of Maneuver Units	5-15

ALLOCATION OF FORCES

Stinger assets of a division are consolidated at the Chaparral/Vulcan (C/V) battalion and are allocated in accordance with the division commander's priorities. Once priorities are established the C/V battalion commander will task-organize to defend these priorities. Priorities may include forward maneuver brigades, cavalry squadron, artillery units or point targets; i.e., bridges.

ORGANIZING FOR COMBAT

When task organizing for combat, certain general guidelines are applicable to any type of operation. The organization must support the tactical plan; for example, the force at the critical point must be strong enough to do the job. The platoon is designed to operate with four sections. Allocate enough time for sections to move into the supported maneuver unit area. Anticipate future requirements — organize so that minimum changes will be required.

At brigade level, task organizing of ADA assets allocated by the division commander for a particular operation is based on the brigade commander's priorities for air defense. The ADA commander must retain sufficient control to react to rapid changes in air defense priorities which come about by changes in the ground commander's scheme of maneuver. Normally at brigade level, the ADA battery commander will task organize the ADA assets for the brigade. The Stinger platoon leader may help in this task.

★ A maneuver battalion may require more or less than five teams; there may be instances where a maneuver battalion requires no Stinger teams. To support these

varying requirements, the Stinger platoon leader retains the flexibility to adjust the number of teams in the sections in accordance with the tactical situation.

Additionally, the SHORAD battalion commander retains the flexibility to adjust the number of sections in Stinger platoons. For example, if a brigade is organized with more than three battalions and has more than one supporting field artillery battalion, the SHORAD battalion commander may detach sections from other Stinger platoons and attach them to the Stinger platoon supporting the brigade.

The platoon's success in combat is based on the skillful use of its Stinger assets. To properly task organize at this level, leaders must have a clear understanding of the capabilities and limitations of the section, teams, and Stinger weapons they have available to allocate.

At times, a Stinger platoon may provide the only air defense for a brigade. In this case, the platoon leader makes recommendations to the commander on air defense priorities and task organizing.

TACTICAL MISSIONS

The role of the Stinger weapon system is to provide air defense against hostile low-altitude rotary and fixed-wing aircraft for critical assets of the supported organization. The ADA commander selects the appropriate tactical mission for his subordinate elements based on the mission he receives and on the tactical situation which confronts him.

Therefore, the tactical mission received by your platoon can be an ADA standard tactical mission, an ADA standard tactical mission, with certain elements modified or deleted, or a specific narrative mission.

An ADA standard tactical mission can be assigned to any type of ADA unit and

assigns specific responsibilities to the receiving unit and establishes a specific and definite command relationship between the supported and supporting unit. Four ADA standard tactical missions are: general support (GS), general support-reinforcing (GS-R), reinforcing (R), and direct support (DS).

GENERAL SUPPORT

An ADA unit with a GS mission provides air defense for the force as a whole. It supports the entire force and is not committed to any specific element of the force. This is the case where a Stinger section could be in GS of a battalion as a whole. Also, a Stinger platoon may be placed in GS of a brigade as a whole.

GENERAL SUPPORT-REINFORCING

An ADA unit with a GS-R mission primarily provides air defense for the force as a whole. Secondly, it also augments the coverage of another ADA unit. GS-R units are not committed to any specific element of the force. An example may be a Stinger platoon primarily supporting a whole brigade and secondarily reinforcing coverage of a Vulcan platoon which is DS to a maneuver battalion. This tactical mission is seldom used for Stinger.

REINFORCING

An ADA unit with a reinforcing mission augments the coverage of another ADA unit.

Both ADA units are committed to a specific element of the force. This tactical mission is seldom used for Stinger.

DIRECT SUPPORT

An ADA unit with a DS mission provides dedicated air defense for a specific element of the force that does not have its own ADA. The ADA unit is committed to that specific element of the force. For example, a Stinger section may be placed in DS of a maneuver battalion for a certain operation. This mission is used frequently with Stinger.

ADA standard tactical missions can be assigned to any type ADA unit. This does not mean that any one standard tactical mission is the norm for a particular type unit. It is possible that none of the ADA standard tactical missions will apply in particular situations. In such a case, the ADA commander might issue a standard tactical mission with certain elements modified. Or he might avoid the use of standard tactical missions altogether and issue only a specific narrative mission. Therefore, it is incorrect to say, for instance, that DS is the normal tactical mission for Stinger. Direct support is a possible Stinger mission, but by no means the normal Stinger mission.

The standard tactical mission definition states that such missions assign specific responsibilities to the receiving unit. The responsibilities of each ADA standard tactical mission are summarized in matrix form.

REMEMBER

THE PLATOON OR SECTION MAY NOT ALWAYS RECEIVE A STANDARD TACTICAL MISSION. THE PLATOON LEADER/SECTION CHIEF MAY RECEIVE A SPECIFIC NARRATIVE MISSION OR A STANDARD TACTICAL MISSION WITH CERTAIN ELEMENTS MODIFIED OR DELETED. THE MISSION MAY BE TO PARTICIPATE IN AN ALREADY ESTABLISHED DEFENSE OR TO ESTABLISH A DEFENSE IN CONJUNCTION WITH OTHER STINGER UNITS.

★ RESPONSIBILITIES OF ADA STANDARD TACTICAL MISSIONS				
MATRIX	GENERAL SUPPORT (GS)	GENERAL SUPPORT-REINFORCING (GS-R)	REINFORCING (R)	DIRECT SUPPORT (DS)
WHO ESTABLISHES AD PRIORITIES?	THE FORCE COMMANDER.	(1) THE FORCE COMMANDER. (2) THE SUPPORTED COMMANDER THROUGH THE REINFORCED ADA COMMANDER.	THE SUPPORTED COMMANDER THROUGH THE REINFORCED ADA COMMANDER.	THE SUPPORTED COMMANDER.
WHO LOCATES THE ADA UNIT?	THE COMMANDER ASSIGNING THE MISSION IN COORDINATION WITH THE SUPPORTED GROUND FORCE COMMANDER.	THE COMMANDER ASSIGNING THE MISSION IN COORDINATION WITH THE SUPPORTED GROUND FORCE COMMANDER.	THE REINFORCED ADA COMMANDER IN COORDINATION WITH THE SUPPORTED GROUND FORCE COMMANDER.	THE DS ADA COMMANDER WITH APPROVAL OF THE LOCAL GROUND FORCE COMMANDER.
WHO POSITIONS ADA FIRE UNITS?	ADA FIRE UNIT COMMANDERS IN COORDINATION WITH THE LOCAL GROUND FORCE COMMANDER.	ADA FIRE UNIT COMMANDERS IN COORDINATION WITH THE REINFORCED ADA UNIT COMMANDER AND THE LOCAL GROUND FORCE COMMANDER.	ADA FIRE UNIT COMMANDERS WITH APPROVAL OF THE REINFORCED ADA UNIT COMMANDER AND THE LOCAL GROUND FORCE COMMANDER.	ADA FIRE UNIT COMMANDERS WITH APPROVAL OF THE LOCAL GROUND FORCE COMMANDER.
WITH WHOM SHOULD LIAISON BE ESTABLISHED?	AS REQUIRED.	AS REQUIRED, BUT INCLUDING THE REINFORCED ADA COMMANDER.	AS REQUIRED, BUT INCLUDING THE REINFORCED ADA COMMANDER.	SUPPORTED UNIT COMMANDER.
WITH WHOM SHOULD COMMUNICATIONS BE ESTABLISHED?	AS REQUIRED.	AS REQUIRED, BUT INCLUDING THE REINFORCED ADA UNIT.	AS REQUIRED, BUT INCLUDING THE REINFORCED ADA UNIT.	SUPPORTED UNIT.
WHERE DOES THE LOGISTICAL SUPPORT COME FROM?	ADA UNIT.	ADA UNIT.	ADA UNIT.	SUPPORTED UNIT IS RESPONSIBLE FOR ALL CLASSES OF SUPPLY WITHIN THEIR CAPABILITIES.

Notes:

1. The term "locating" specifies the establishment of a broad operating area (commonly, a "goose egg").
2. The term "positioning" specifies the selection of an exact point within the operating area. (Although not addressed in this chapter, the term "siting" specifies the placement of individual items of equipment on selected spots within the position.)

TYPES OF AIR DEFENSE

AREA DEFENSE

This defense type is reserved by friendly Air Force units. (Stinger does not participate in this type defense.)

BELT DEFENSE

This is a specialized application of area defense. It places limited ADA weapons in a strict attrition role. A belt defense is not normal ADA employment. (Stinger does not participate in this type defense.)

POINT DEFENSE

This is defense of a limited area, normally in the defense of the vital elements of a force or the vital installations of the rear zone. The asset defended can be either mobile or static. (A point defense is the air defense normally used by all ADA units including Stinger.)

SELF-DEFENSE

This type of defense is used by friendly units to defend themselves against air attack through the use of organic weapons. (Stinger participates in this type defense.)

SECTION II

AIR DEFENSE PLANNING

AIR DEFENSE EMPLOYMENT PRINCIPLES

Four basic principles govern the employment of all air defense weapons: Mass, Mix, Mobility, and Integration. These principles provide the foundation for the employment doctrine and tactics discussed in this chapter.

MASS

This is achieved by allocating enough Stinger air defense weapons to adequately defend the asset. For example, a Stinger section is the minimum force that can defend a maneuver battalion. If the threat is severe or if the battalion is widely scattered, two sections may be required to obtain the mass necessary to defend the battalion.

principles of mass and mix on a dynamic battlefield. Continual movement of air defense units is required to provide protection for moving point defenses (maneuver elements).

Stinger teams must be able to move continually with armor and mechanized infantry forces, reacting to the frequent changes in missions and priorities. Stinger teams should possess mobility equal to the maneuver element they are supporting.

MIX

This is achieved by employing different types of air defense weapons together to defeat the air threat. When a variety of weapons are used together, air defense is more effective. Thus, a mixture of Vulcan guns and Stinger weapons augmented by small arms, all differing in characteristics, offers a better defense than Stinger alone.

INTEGRATION

This is achieved by tying all ADA weapons together in a common effort and by coordinating air defense with maneuver. Effective command, control, and communications links must be established between all levels of the air defense artillery organization and with each maneuver element receiving air defense support.

MOBILITY

This permits the application of the

Stinger is integrated into the overall air battle through application of the air defense commander's rules and procedures. It is integrated into the maneuver force through coordination between the Stinger platoon leader and the maneuver force commander.

The Stinger platoon leader and his commander must also be guided by these principles when deciding where and how to use Stinger sections and teams.

AIR DEFENSE ARTILLERY EMPLOYMENT GUIDELINES

Certain general guidelines must be considered by Stinger platoon and section chiefs when designing defenses and selecting locations for Stinger teams. These include balance fires, overlapping fires, weighted coverage, mutual support, early engagement, and defense in depth.

★ BALANCED FIRES

Since critical assets will often be attacked as targets of opportunity, attack can come from any direction. It is, therefore, desirable to have equal firepower in all directions. On rare occasions, enemy aircraft may be confined to a well-defined avenue of approach. Balance may then be sacrificed and the defense weighted in the direction of attack. This should be done, however, only when there is little possibility of an attack from another direction.

★ OVERLAPPING FIRES

Teams are normally positioned so that the engagement capability of one team overlaps that of an adjacent team. By

following this guideline, the section chief can guard against the possibility that an aircraft will slip through the defense without being engaged by at least one Stinger team. The maximum overlapping fire distance between teams is 4,000 meters. In cases where more than one weapon system is employed in the same defense, overlapping fires should be achieved between *LIKE* weapon systems.

★ WEIGHING COVERAGE

In unusual circumstances, such as when terrain restricts low-level attacks in particular directions or when intelligence has established that air attacks will come from a particular direction, a defense can be weighted.

★ MUTUAL SUPPORT

Mutual support allows one Stinger team to fire into the dead zone of another Stinger team. The maximum mutual support distance between teams is 2,000 meters.

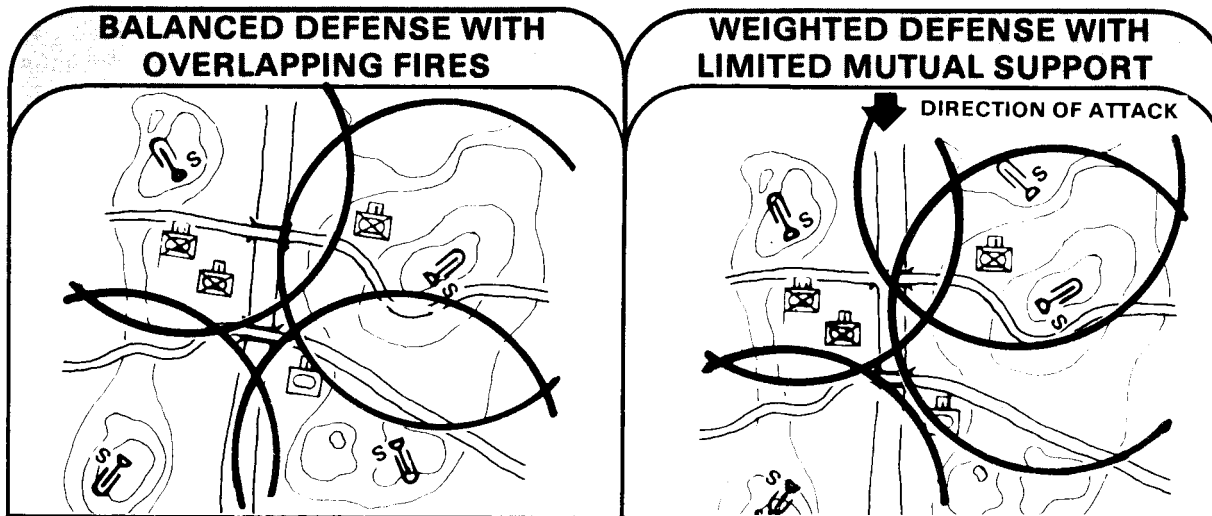

EARLY ENGAGEMENT

Stinger teams should be positioned so that they can engage an aircraft before it can attack the unit or asset being defended. This means that teams should be positioned out away from the asset being defended or well forward in the direction of the expected air attack.

★ Ideally, an attacking aircraft should be engaged and destroyed before it can release its ordnance. The range at which an aircraft can release ordnance on a target is defined by an ordnance release line (ORL). The ORL will, of course, vary with the type of ordnance, the attack technique used, and the speed and altitude of the aircraft. In general, the Stinger section leader should plan for a defense against aircraft using the pop-up technique. The range of the ORL for this type of attack varies from 500-1,500 meters.

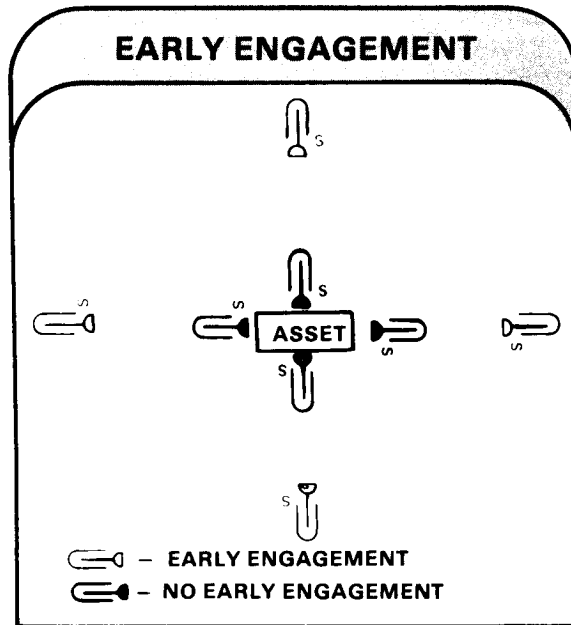

DEFENSE IN DEPTH

This is that quality of a defense which allows supporting fire units to absorb and progressively weaken attack, prevent observation of the asset by the enemy, and

allow the supported commander to maneuver his reserve. It is achieved through adherence to all the other employment guidelines.

STINGER DEFENSE DESIGN REQUIREMENTS

★ Besides the principles and guidelines discussed previously, other considerations must be taken into account when planning a defense. Discussed below are the requirements and situations under which the principles and guidelines are applied. In some cases, it may be advisable to use effectiveness templates when planning a Stinger defense. Sample effectiveness templates are shown in (SNF) FM 44-1A(U).

SCHEME OF MANEUVER

The Stinger platoon leader/section chief must know the ground commander's scheme of maneuver before he can plan a successful defense.

AIR DEFENSE PRIORITIES

Air defense priorities provide the basis for the Stinger platoon organization for combat. Since the number of assets which may require Stinger protection usually exceeds the number of weapons available to adequately protect them, a priority listing must be developed. Air defense priorities are established for every operation and for each course of action considered by the supported

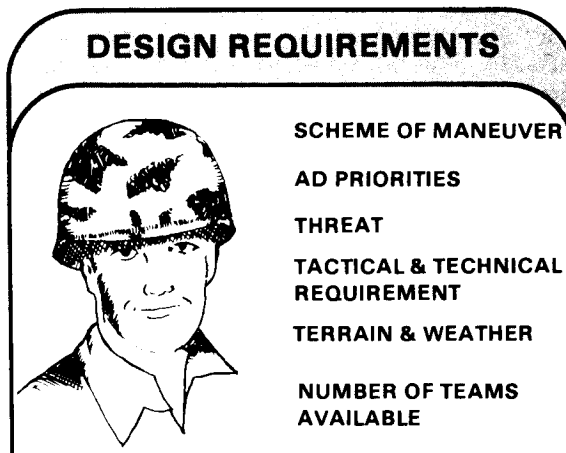

commander and staff. The development of the priority list is essentially a matter of assessing each element of the supported unit as a potential target for enemy air attack. Factors considered include:

Criticality. The supported unit commander makes a determination on the importance of various assets to the success of the operation. For example, a bridge may be deemed to be absolutely essential to the advance of a battalion which will conduct a river crossing operation. Air defense of this bridge then might have a higher priority for air defense and requires more ADA weapons than other less important assets.

Vulnerability. Another consideration is vulnerability. Some assets may be hardened or hidden while others are required to be in the open. Others may be naturally more vulnerable to damage from air attack. For example, a bomb dropped on a fuel dump will cause much more damage to combat capability than the same bomb dropped on a tank company.

★ **Recuperability.** This considers how fast an asset can recover from damage inflicted to again perform its mission. At times, recuperability can become of prime importance. For instance, if fuel is critically short, a fuel dump could not be recouped quickly. It would, therefore, be important to protect that asset. When fuel becomes available, the importance of the fuel dump might be decreased.

Sufficient air defense artillery assets to cover all possible targets may not be available. The commander may be able to relocate or consolidate assets to make the most of available air defense. For instance, a battalion's trains might be shifted closer to battalion TOC so that it can be afforded some Stinger protection.

★ Once priorities have been established, the SHORAD battery commander, in conjunction with his Stinger platoon leader, determines how his sections and teams should be allocated and, if appropriate, what positions they should occupy. At the battalion level, the Stinger section chief may operate in the

same manner as the platoon leader at the higher level. In a point defense, Stinger may be employed alone or be integrated with other divisional air defense weapons.

THREAT

★ In considering the threat, the Stinger leader asks himself two questions. What types of aircraft, ordnance, IR, and ECM has the threat been using in the area? How can the threat be expected to attack the defended unit?

★ The enemy air threat is perhaps the most difficult factor to evaluate. It is difficult to estimate what targets the enemy will attack and what tactics he will use. For example, if a helicopter threat exists, maneuver company teams in the forward area provide lucrative targets because of the threat ATGM capability and should receive priority for Stinger assets. Primary targets will be those targets that will stop or slow their attack, such as tanks, ATGM, and hard points. They will try to destroy these targets to achieve a breakthrough.

TACTICAL AND TECHNICAL REQUIREMENTS

When selecting positions for Stinger teams, the following must be considered:

Observation and Fields of Fire. This is the primary consideration. Positions should be selected that provide all-around visibility and allow the weapon to be fired in any direction. Positions should ideally have at least 5 km of observation in the direction from which attack is expected. When employed with other Stinger teams in a point defense, the prime consideration for position selection is visibility within its assigned sector closest to its primary target.

Communications. Positions selected should offer good line-of-sight communications with the Stinger section headquarters, unit being supported, and the FAAR being used for early warning. If the team cannot communicate from its position, the position is unsatisfactory.

Physical Security. Team positions must have protection from ground attack. Teams must be positioned within or near friendly units for security against ground attack. This is particularly true when teams are supporting units in the forward area. Also, teams must have protection against enemy ground fires. Masking between the position and the enemy hides the position from enemy ground observation and suppressive actions.

Cover and Concealment. Firing positions should offer cover and concealment so the team is afforded protection from enemy observation and fire. Because of the dust and smoke signature produced by a missile firing, the enemy can spot a Stinger firing position and attack it. Therefore, the team must seek and obtain cover and concealment immediately after firing. The team's vehicle and trailer must also be camouflaged.

Accessibility for Team Vehicles. The position should be easy for the team vehicle to move into. Concealed routes are necessary

to the rear and flanks for rapid shifting of position. The team must be relatively close to the vehicle for access to the basic load. If the selected team firing position is too far from the team vehicle, the team will have difficulty in off-loading and carrying Stinger weapons. Also, the team will have to carry other equipment to the site, such as TADDS, field wire, and the remote control unit for communications. Another consideration is good accessibility for the team vehicle when the team must move quickly to an alternate position.

Technical Requirement. The technical requirements of the Stinger weapon position pertain to safety. The gunner must insure that the area behind the weapon is clear of other personnel to a distance of 50 meters (164 feet). The team chief should be close to the gunner's side and insure that he is not endangered by the weapon backblast. Also, the gunner should allow at least 5 meters safety distance from equipment (e.g., a vehicle).

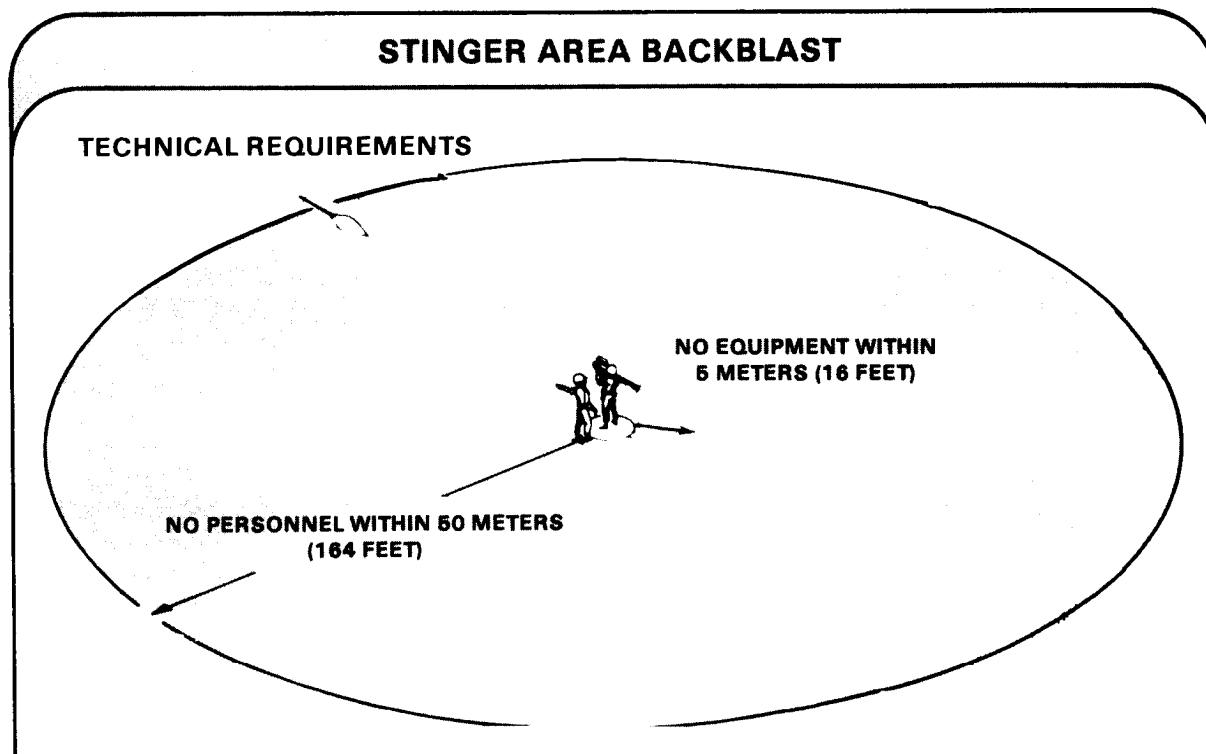

TERRAIN AND WEATHER

Hilly terrain presents masking problems for the employment of Stinger. Also, hilly terrain restricts communications, acts to inhibit team mobility, and increases the supply problem. Weather can adversely affect Stinger ir acquisition range. For example, rain, snow, and fog will absorb and scatter ir radiations and reduce ir range. Also, rain, snow, dust, fog, smoke, heat shimmer, and haze tend to reduce visibility which reduces the range of visual detection of aircraft. The effects of terrain and weather can thus influence the number of Stinger teams needed, and their locations to defend the asset.

NUMBER OF TEAMS AVAILABLE

As a general rule Stinger teams may not be available in sufficient numbers to defend all the ground commander's assets. The Stinger platoon leader must therefore make

this fact known to the supported unit commanders and make recommendations on how many assets he can defend.

REMEMBER

THESE EMPLOYMENT GUIDELINES ARE NOT HARD AND FAST RULES TO BE COMPLIED WITH IN EVERY POSSIBLE SITUATION.

OFTEN, STINGER SECTION CHIEFS AND TEAM CHIEFS WILL NOT BE ABLE TO COMPLY WITH ALL THESE GUIDELINES IN SELECTING POSITIONS FOR STINGER TEAMS. THE CHOICE OF THE BEST POSITIONS USUALLY INVOLVES A COMPROMISE OR TRADE-OFF BETWEEN THESE GENERAL GUIDELINES. THE DECISION AS TO WHICH GUIDELINES WILL BE ACCORDED PRIORITY IS SITUATION DEPENDENT AND IS DRIVEN BY THE DEFENSE DESIGN REQUIREMENTS.

SECTION III

DIFFERENT DEFENSE CONSIDERATIONS

★ STATIC CRITICAL ASSET DEFENSE

Stinger's capability to engage approaching aircraft makes it a valuable weapon for a static critical asset defense. It is especially effective when combined with other air defense weapon systems in a mixed and integrated defense.

The first step in planning a defense is to define the area to be defended. The area to be defended is defined by the borders of the asset increased by the radius of effect of the most likely weapon the enemy may use. This information should be plotted on a map. The C/V battalion and/or the supported unit S2 can usually provide information on the expected threat.

Vital points within a defense and routes of approach must also be considered before the planner can say he has adequately defined the area to be defended:

★ VITAL POINTS WITHIN A CRITICAL ASSET DEFENSE

Within a fairly large critical asset defense, certain assets will probably be of higher priority than others. The commander may be able to accept limited amounts of damage in some parts of the defense and unable to accept any damage in others. In these cases, coverage should favor the high-priority assets.

ROUTES OF APPROACH

Routes of approach fall into two general categories, probable and forced. A probable route of approach is one that the enemy is likely to use, but is not restricted to use. The pilot of an aircraft traveling at 500 knots 150 meters above the ground can see little detail on the ground. He can, however, see large objects such as highways, rivers, and

mountain ranges and may use them to assist in navigation. If such landmarks lead to a critical asset, they may be considered as in or near the probable route of approach. A forced route of approach is one that the attacker is compelled to use. When considering probable routes of approach, the planner may favor the routes in his coverage but balance cannot be disregarded completely. Balance is completely abandoned in favor of weighted coverage when considering forced routes of approach.

★ THREAT CHARACTERISTICS AND ORDNANCE RELEASE LINE

A thorough knowledge of enemy capabilities and techniques is essential when planning a defense. Chapter 1 of this manual describes attack techniques Stinger personnel will encounter.

In most cases, damage to an asset can result from an indirect hit within the radius of effect of the weapon the enemy chooses to use. Additionally, the fact that an enemy pilot may release the weapon at a distance from the asset, and not directly above it must be considered. Considering these factors, it then becomes the objective of the Stinger platoon/section leaders to organize a defense that insures engagement of the target prior to the point at which a weapon can be released.

★ The ordnance release line (ORL) will vary with the type of attack used. Since Stinger is designed to counter low-altitude aircraft, the ORL for the pop-up type attack should be used in planning — 1.5 kilometers is generally a good figure to use. In some instances, however, ordnance may be released farther from the target. If a pilot desires to attack an area, rather than a point, the ORL may be as much as 2 to 3 kilometers from the target. Unless there is terrain masking, Stinger's forward aspect capability will compensate for this.

Once the area to be defended has been defined, the defense planner must position his teams in accordance with the employment guidelines of balance,

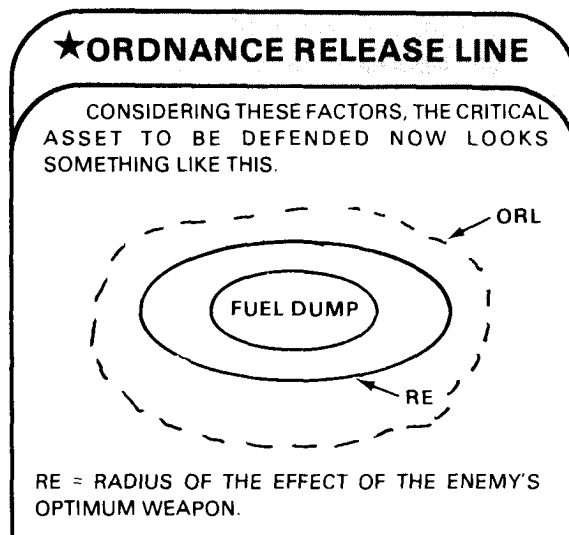
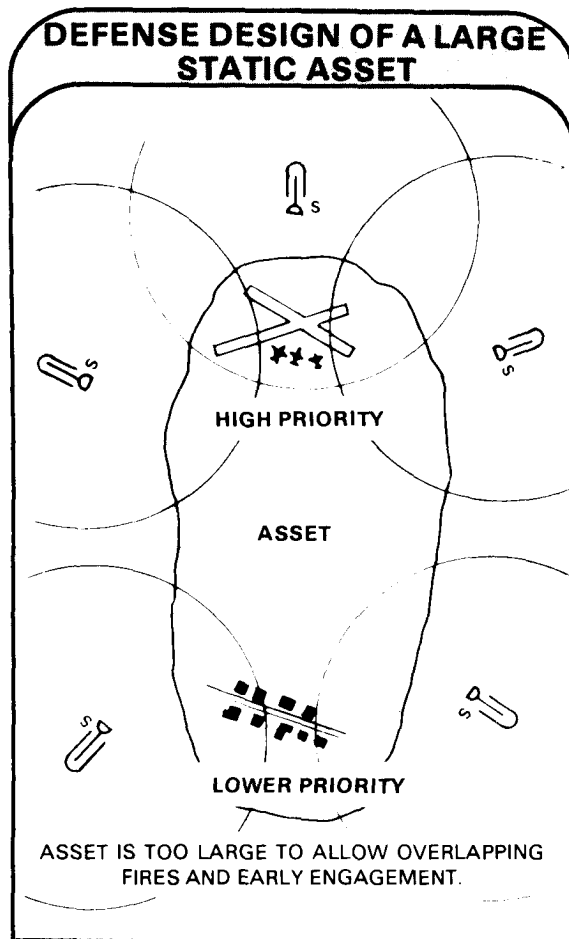

overlapping fires, early engagement, and weighted defense.

MAP ANALYSIS AND PLANNING

Once the section chief has defined the area to be defended and plotted it on a map, he begins his map analysis. The section chief often will have to make decisions quickly and will not have time for a detailed analysis. The map analysis described below will serve as a logical base upon which to make decisions.

The section chief must identify two things in this analysis — team positions and

any areas the teams cannot cover as placed.

An incoming low-flying aircraft is masked to position A as shown below because position A is at a lower elevation than hill 101; therefore, a team at position A may not see a target until it is on this side of hill 101. The team at position B can see beyond hill 101; therefore, it can capitalize on early detection and the forward aspect capability of the weapon. The section chief selects position B over position A.

While this method is not particularly accurate, it does provide the section chief with a good idea of what positions are best for his teams. These positions may have to be further adjusted after a ground reconnaissance is conducted.

Once the final position is selected, the section chief must coordinate those locations with the supported S3.

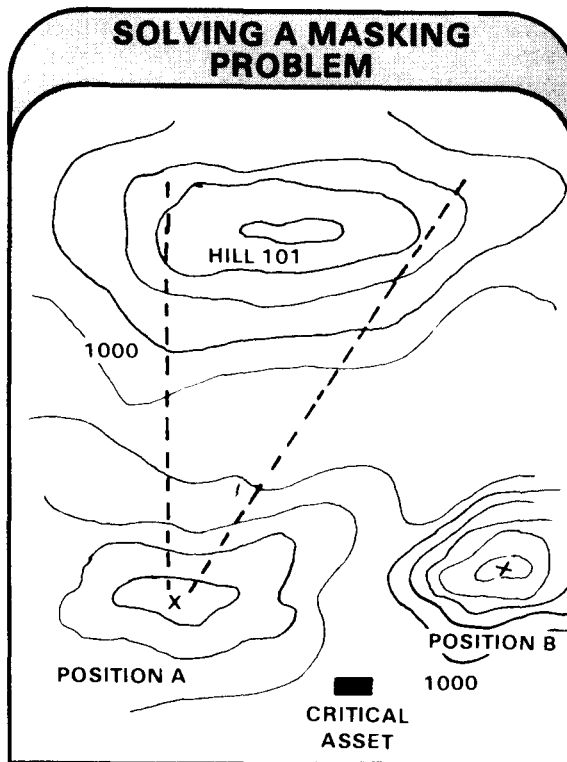
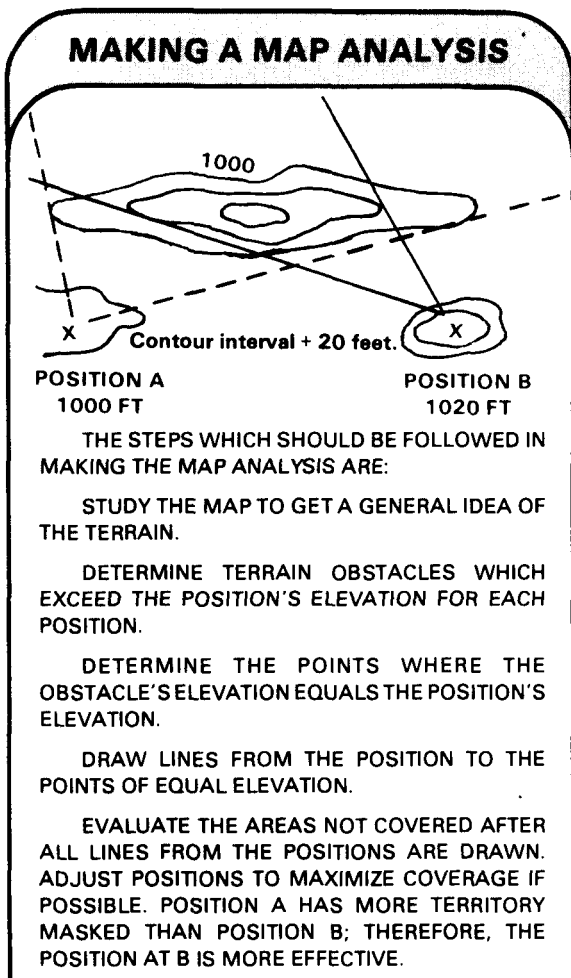

★ MOBILE CRITICAL ASSET DEFENSE CONVOYS

Stinger teams will often be required to provide air defense for units while they are moving in convoy or march column along roads behind the line of contact. Units in convoy will usually be moving at a speed of 15-20 mph in either an open column (50-100 meters between vehicles) or closed column (50 meters or less between vehicles). The total length of the convoy will, of course, vary depending on the spacing of the vehicles and the size of the unit. For example, in closed column, a mechanized infantry battalion is about 6 kilometers long and in open column about 18 kilometers long. A field artillery battery in closed column is approximately 1/2 kilometer long and in open column about 2 kilometers long.

When traveling in convoy under conditions of good visibility, units are likely targets and are vulnerable to attack by enemy air. As with the defense of units in position behind the line of contact, attack by high-performance aircraft is the primary concern; attack by helicopters is less likely.

March columns are more likely to be attacked as targets of opportunity, rather than as preplanned targets. This means, in essence, that the pilots of enemy aircraft must first find and pinpoint the location of the targets before making an attack run. An attack on a convoy by a flight of aircraft is described in chapter 1.

Stinger can be employed to defend a convoy by pre-positioning Stinger teams along the march route or by integrating Stinger teams into the march column.

PRE-POSITIONING TEAMS ALONG THE ROUTE OF MARCH

Stinger teams may be pre-positioned to defend a convoy as it passes a critical point along the route. This is the preferred way of defending a convoy, if the tactical situation permits. This method of employment can be considered when a critical point can be

identified along the route where the convoy is likely to be forced to bottleneck or may halt; such as at bridges which could be destroyed before or as the unit crosses, road junctions where other traffic may slow or halt the column, or refueling points. This method can be used when the distance to be traveled by the convoy is relatively short (e.g., about 5 kilometers); or when circumstances will permit Stinger teams to join and be integrated with the column after it passes the critical point.

Pre-positioned teams can be used only if the route is relatively secure from ground attack. This allows pre-positioning of Stinger teams at the critical point. Stinger teams can move out ahead of the column and occupy positions prior to the convoy passing the critical points.

The enemy may preplan air strikes at critical points such as crossroads and bridges along march routes. Since these points are readily identifiable from the air, there is a higher probability of attack on the first pass by enemy aircraft. Accordingly, when possible, an early engagement capability against any direction of attack should be provided.

When establishing a point defense along the march route, the employment guidelines for Stinger are applied in the same way as when defending a stationary point defense behind the line of contact. Once the convoy passes the critical point, Stinger is moved ahead to another critical point. Stinger teams are often employed in leapfrog style to insure continuous protection along the route of march. This tactic is extremely difficult to employ if there is only one congested primary route.

INTEGRATING TEAMS INTO THE MARCH COLUMN

★ If only one team is available, the team should not be split. When teams are split,

efficiency is greatly degraded. The ADA planner should employ a sufficient number of

systems to achieve mutual support or overlapping coverage.

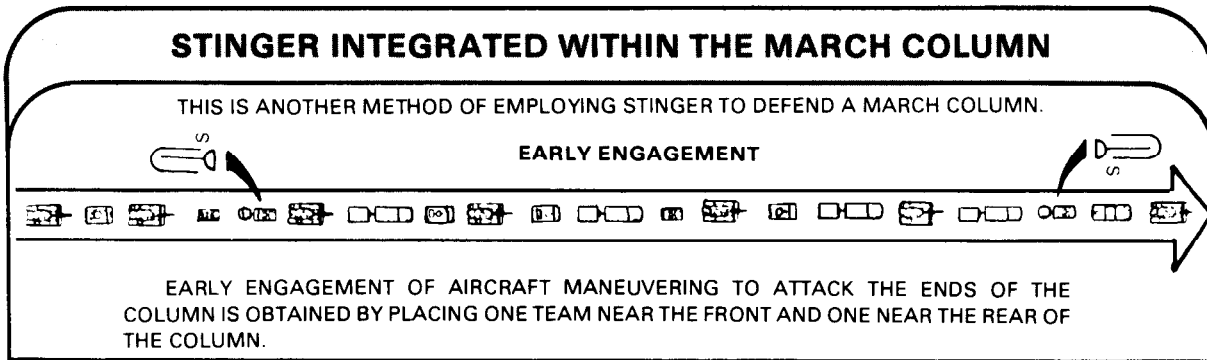

When air attack is imminent, or in progress, the Stinger team moves its vehicle off the road and quickly dismounts. The team takes up the best available firing position — a position from which the aircraft can be seen and Stinger can be safely fired.

before it makes its attack run on the convoy. Stinger teams should be ordered to hold fire against enemy aircraft only when WEAPONS HOLD is in effect. This also applies when it is necessary to support the commander's concept of the operation; for example, to support a deception operation.

★ When possible, the Stinger team engages the aircraft on its first pass and

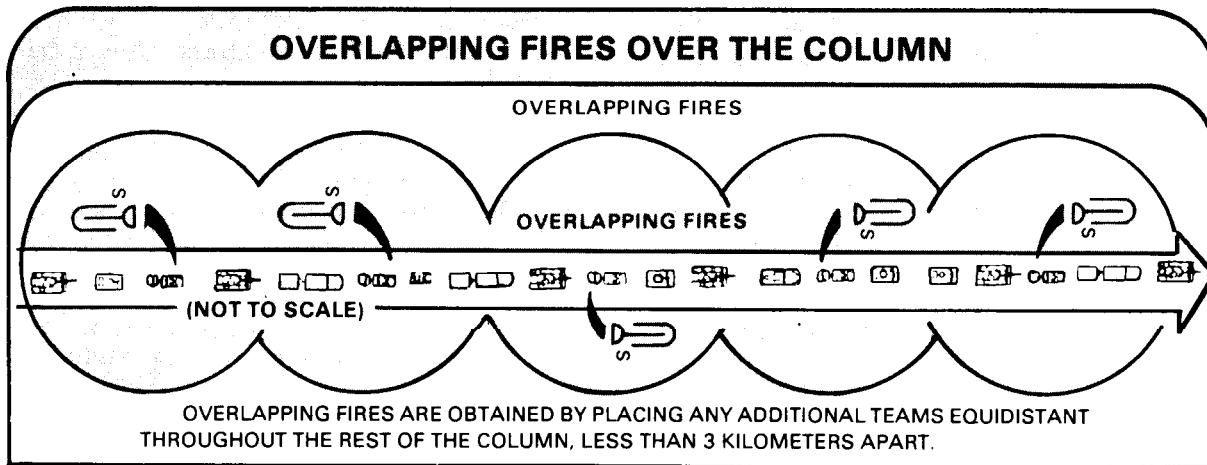

When the column is attacked, the massed fires of all available small arms, machine guns, Stinger, and any supporting ADA weapons are placed on the attacker to destroy him, drive him away, or cause his ordnance

delivery to be ineffective. When the immediate threat of air attack has subsided, the Stinger team resumes its assigned position within the convoy, passing other vehicles as necessary to regain this position.

DEFENSE OF MANEUVER UNITS

Defending maneuver elements in offensive and defensive operations are covered in detail in chapter 7. Certain general considerations apply to both operations. A Stinger section defending a maneuver battalion will generally be closer to the forward edge of the battle area than one defending a fixed asset. Three factors take on a high degree of importance. These factors are physical security, mobility, and position requirements.

PHYSICAL SECURITY

Physical security becomes a primary consideration. To perform their mission effectively, Stinger teams must be reasonably secure from ground attack. This may preclude positioning teams in front of maneuver elements. The early engagement capability is reduced to insure physical security of the Stinger team.

MOBILITY

Mobility is the second major consideration. The Stinger team must have the capability to move and shoot to keep up with maneuvering combat elements. This mobility must be achieved and maintained to insure air defense protection to the maneuver force. The mobility of the Stinger teams must be the same as that of the supported force.

POSITION REQUIREMENTS

*Position requirements is the third major consideration. The Stinger section chief should position his teams as close behind maneuvering elements as possible. The positions should provide all-around observation and if possible have line of sight with a FAAR. This usually dictates positions on high terrain. If a position with all-around observation is not available, then a position from which the team can at least see in the direction of the enemy avenue of approach is desirable. The section chiefs position must also have line of sight for communication with the Stinger teams and the supported unit.

As a general rule, Stinger teams should overwatch maneuvering elements from good positions. Maneuver elements are most vulnerable to air attack when moving; therefore, Stinger teams must be prepared to fire at all times.

Maneuver units in the forward area can expect attacks by both high-performance aircraft and helicopters. Although attacks from any direction are possible, attacks from the general direction of the enemy ground forces are most likely. Enemy aircraft will probably approach their targets on routes generally perpendicular to or parallel with the forward line of own troops (FLOT). Aircraft may even penetrate and attack the point defense from the rear if they have any remaining ordnance. Maneuver units are more likely to be attacked as targets of opportunity than as preplanned targets. Therefore, jet aircraft attack techniques may be similar to those depicted for the attack of march columns wherein the aircraft pilot first finds and fries his target and then attacks.

★ When two or more Stinger teams are supporting one company team, they should normally be separated, with teams on opposite flanks or ends of the unit's formation to improve early engagement against aircraft attacking from various directions. The dimensions of the company team formation are usually small enough to permit overlapping fires between Stinger teams positioned in this manner,

Remember, when a company team comes under air attack, it should temporarily divert some or all of its small arms and machine guns to an air defense role to assist Stinger and other supporting ADA weapons in destroying or driving off attacking aircraft.

The allocation of Stinger teams, both to the support of committed maneuver companies and to the defense of other assets in the task force rear area, will often provide a bonus effect of early engagement and overlapping fires. To illustrate by example, a

battalion task force is in a defensive position with its company teams deployed along the FEBA. The TOC, trains, and heavy mortar platoon are to the rear as shown.

One Stinger team has been allocated to each company, one team to the battalion

TOC, and one team to the heavy mortar platoon. The Stinger teams have been positioned to defend these individual assets.

Shown below are considerations when in the defense of a task force as a whole.

EARLY ENGAGEMENT FROM FRONT AND REAR

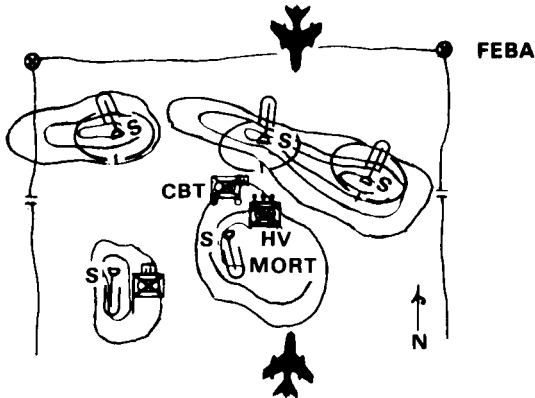

THE STINGER TEAMS SUPPORTING THE COMPANIES PROVIDE AN EARLY ENGAGEMENT CAPABILITY AGAINST JET AIRCRAFT ATTACKING ASSETS IN THE TASK FORCE REAR AREA FROM THE NORTH.

THE STINGER TEAMS PROTECTING THE TASK FORCE ASSET IN THE REAR PROVIDE AN EARLY ENGAGEMENT CAPABILITY AGAINST JET AIRCRAFT ATTACKING THE COMPANY TEAMS FROM THE SOUTH.

EARLY ENGAGEMENT FROM FLANKS

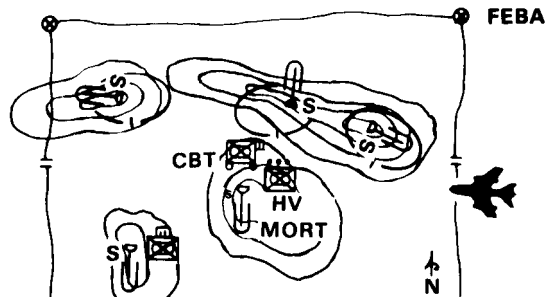

THE STINGER TEAMS SUPPORTING THE COMPANIES ON THE FLANKS PROVIDE AN EARLY ENGAGEMENT CAPABILITY AGAINST JET AIRCRAFT ATTACKING THE TASK FORCE FROM THE EAST OR WEST.

★ OVERLAPPING FIRES

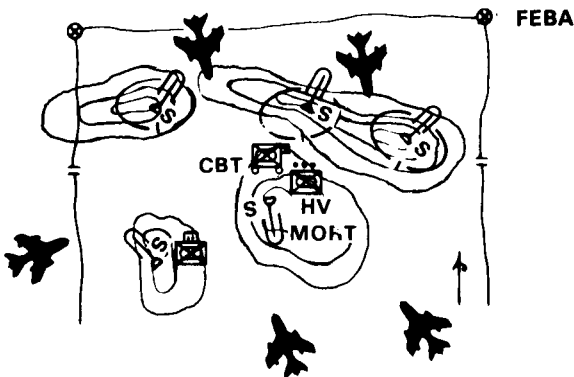

THE LOCATIONS OF THE STINGER TEAMS ARE SUCH THAT OVERLAPPING FIRES AGAINST AIRCRAFT ATTACKING FROM DIFFERENT DIRECTIONS ARE POSSIBLE.

REFERENCE (SNF) FM 44-1A (U), FOR STINGER WEAPON SYSTEM PARAMETERS (LAUNCH AND INTERCEPT BOUNDARIES) FOR VARIOUS SPEED TARGETS.

CHAPTER 6

Stinger Platoon Operations

Command control of the Stinger platoon is performed by the Stinger platoon leader from his headquarters element. To insure coordination and integration of the Stinger sections in the overall air defense for the supported unit, he normally locates his headquarters element in the vicinity of his parent battery. The purpose of the Stinger headquarters element is to command and control Stinger sections and teams, collect and pass on pertinent information to the sections, and position Stinger teams as required to support the mission.

This chapter will discuss how platoon and section headquarters personnel operate in combat. It describes how platoon personnel prepare for combat operations and how they accomplish their mission.

COMMAND RELATIONSHIPS

In the division, the Stinger platoon operates as an element of either a Chaparral or a Vulcan battery. When an ADA battery is supporting a maneuver force, the battery commander is the air defense artillery officer for that maneuver force. For example, when a Vulcan battery is in direct support of a brigade, the Vulcan battery commander is the principal adviser to the brigade commander on air defense matters. The Stinger platoon leader is a subordinate ADA unit leader. He provides assistance to the commander on Stinger matters and receives direction on Stinger employment.

When not deployed with a higher level ADA unit, the Stinger platoon leader can

serve as the supported unit's air defense advisor. This situation occurs when, through the process of organizing for combat, the Stinger platoon is the sole air defense unit providing air defense for a maneuver force.

This would also be the case where a Stinger platoon is organic to a separate brigade/regiment. Once priorities are established by the commander, the Stinger platoon leader develops the plans and orders necessary to defend the unit against air attack. The Stinger platoon leader receives direction from the commander/S3 for Stinger employment.

CONTENTS

	PAGE		PAGE
Command Relationships	6-1	Platoon Operations	6-7
Troop Leading Procedures	6-2	Platoon Headquarters Internal Operations ...	6-8
SOPs and Combat Orders	6-4	Section Headquarters Internal Operations ..	6-12
Reconnaissance, Selection and Occupation of Position	6-5		

TROOP LEADING PROCEDURES

The platoon leader must prepare for combat by following certain procedures and organizing for the specific mission. To accomplish the tactical mission, the platoon leader should follow a logical sequence. It begins when he is alerted for a mission. It starts all over again when he gets a different mission. In combat, the leader will rarely have time to go through each step of the planning sequence in detail. The steps include

- Receive the mission.
- Issue a warning order (to subordinate leaders).
- Make a tentative plan (that will accomplish the mission).
- Initiate the necessary movement.
- Make the reconnaissance.
- Complete the plan.
- Issue orders.
- Supervise and refine the plan.

Once the battle starts, subsequent orders and responses must be fast, effective, and simple. This requires teamwork and an understanding which permits the leader to turn a mission-type order into action. This action must support the plan of the next higher commander without detailed instructions. The process is not rigid; modify it to fit the mission, situation, and available time.

RECEIVE THE MISSION

Stinger leaders receive a mission in either an oral or written operation order (OPORD) or a fragmentary order (FRAGO). The order is prepared and sent from the battery tactical operation center (TOC) to the Stinger platoon headquarters. It outlines the mission for the unit. A platoon leader may have about 2 to 3 hours time to prepare for the operation; however, time will vary with the tactical situation. The platoon leader should analyze the mission and plan the use of available time.

ISSUE A WARNING ORDER

The platoon leader issues a warning order to the sections, telling his subordinates of the action and the time it is to start. The warning order must be issued early enough for the sections to have time to plan and prepare. Normally, warning orders are issued through the chain of command. This allows all personnel to be kept informed of what they must do and why. A warning order gives advance notice of an action or an order that is to follow. They are usually issued as brief oral or written messages.

EXAMPLE

```
122300T NOV 82 NB 253614
FROM STINGER PLT LDR, B BTRY, 1-18 ADA
TO ALL STINGER SECTION CHIEFS B BTRY,
1-18 ADA
"B BTRY WILL BE RELEASED FROM GS, 32 INF
DIV, AND ASSIGNED DS TO 1ST BDE, 32d INF
(CP-NB294726), EFFECTIVE 130700T.
STINGER SECTIONS WILL BE ASSIGNED DS TO
RESPECTIVE BATTALIONS. MORE INFORMA-
TION TO FOLLOW WHEN BRIGADE OPORD IS
ISSUED."
```

MAKE A TENTATIVE PLAN

If the platoon leader knows the mission and terrain, he can make a quick decision about how the unit can accomplish the mission. This is a tentative plan that he can change if necessary when he goes through the remaining steps. The tentative plan he develops is the basis for coordination, reconnaissance, reorganization (if any), and movement.

INITIATE NECESSARY MOVEMENT

Make good use of available time so that the section chiefs can prepare their teams to move. The platoon leader must have an SOP

to permit these actions to proceed simultaneously so that no time is wasted. The sections may be required to move with their supported unit to provide air defense protection en route. If so, coordination must be effected with the ADA battery commander or convoy commander as the case may be. Such matters as the location of FAARs, new signal instructions, reorganization and maintenance, and any other items not covered by SOP should be taken care of before the movement starts.

MAKE THE RECONNAISSANCE

The platoon leader may or may not see the terrain over which the platoon may fight. In most cases he can only make a map reconnaissance. Combat conditions require the procedure to be completed in a few hours. The positions of Stinger teams are determined in designing the defense. These positions are plotted on a map and represent the tentative location for defense. The platoon leader considers overlapping coverage between weapons, any weighting of the defense desirable, and nature of terrain so far as can be determined from the map. Actual positions must be selected from a ground reconnaissance and may vary within narrow limits from positions selected by map reconnaissance. The platoon leader may accompany the battery commander on his reconnaissance. Whether section representatives accompany the reconnaissance party depends upon the tactical situation and time. In most cases the section chief will accompany the supported battalion reconnaissance party.

COMPLETE THE PLAN

As a result of the reconnaissance, the platoon leader may or may not alter the tentative plan. Focus on specific tasks for all units. Make certain that all team locations are accessible to FAAR for early warning and are coordinated with the supported unit.

ISSUE ORDERS

★ Most orders are issued orally, sometimes from a handwritten, five-paragraph, field-order outline and a sketch or overlay. If the commander has made a reconnaissance, he will issue orders from a vantage point in the assigned area. This permits him to point out particular terrain features on the ground as well as on the map. The commander may issue overlays with his order. He then requires subordinate commanders to copy this information on their own maps. The Stinger platoon leader may or may not accompany his battery commander to hear the brigade order. But at some point in time, he will receive the order. At times he will get the section chiefs together and issue orders to them before an operation. Normally, however, the section chiefs will receive the operations order or FRAGO from the platoon leader during a fast-moving operation. Personnel are briefed in sufficient detail to insure that they understand exactly what they are to do. Items covered during the briefing should include, at a minimum, the enemy situation, the friendly situation, how Stinger will support the operation, ADA rules of engagement, missile resupply status, FAAR locations, frequencies, and any additional material deemed necessary by the platoon leader.

Again, the tactical situation and time will be the deciding factor on how the platoon leaders and section chiefs receive their instructions.

SUPERVISE AND REFINE

Make sure that all arrangements have been made to get the job done. The platoon leader and section chief must supervise to insure that all necessary preparations for conduct of the operation are being made. These include coordination, reorganization, maintenance, resupply, movement, and other required actions. Make sure teams have maps, CEOI extracts, full gas tanks, full basic loads, and reprogrammed IFF interrogators (if needed).

Make provisions for maintenance of communications between the sections and the platoon headquarters. Terrain and distance factors could disrupt radio communications. The platoon headquarters

element must relocate to reestablish radio contact. Once the operation has begun, see that the plan is followed and be prepared to refine the plan as the situation develops.

SOPS AND COMBAT ORDERS

STANDING OPERATING PROCEDURES

The best way to insure that troops quickly understand what a leader wants them to do is to develop SOPs for different situations. Use these SOPs during training. SOPs tell platoons or sections how to react and what the platoon leader/section chief wants them to do. In other words, they preclude having to issue the same instructions every time something needs to be done. This is important because once the battle begins, success or failure may depend on how fast the unit can react to the orders the platoon leader/section chief receives.

There will be situations when special instructions will need to be issued. The time available will determine exactly how to issue the orders. Even when there isn't much time, the ideas shown below will help in issuing clear and complete instructions.

OPERATIONS ORDERS

An operation order is simply a presentation of the information and instructions needed to accomplish a specific mission. The amount of detailed information in the operation order will depend on the information already received and the time allowed for preparation.

The example shows how to organize the platoon order to make sure troops are told everything they need to know. This format will help the platoon leader to prepare his order. Use it as a checklist and remember that it is only a guide. Give the order in words that the troops can understand. For example, he might say, "here's how we're going to do the job," rather than, "execution."

★ EXAMPLE

SITUATION:
INFORMATION ON THREAT AND FRIENDLY FORCES.

THE MISSION AND INTENDED ACTIONS OF AT LEAST THE NEXT HIGHER HEADQUARTERS AND OTHER ADA UNITS IN THE AREA.

MISSION:
WHAT THE UNIT (BATTERY, PLATOON, OR SECTION) IS TO DO.

EXECUTION:
THE TACTICAL PLAN TO ACCOMPLISH THE MISSION.
TASKS FOR EACH PLATOON, OR FOR SECTIONS AND INDIVIDUALS.

SERVICE SUPPORT:
ADMINISTRATIVE INFORMATION TO INCLUDE PLANS FOR -
AMMUNITION.
RESUPPLY.
CASUALTY EVACUATION.
RATIONS.

COMMAND SIGNAL
IFF INFORMATION.
RADIO FREQUENCIES AND CALL SIGNS, SIGNALS, AND OTHER CONTROL MEASURES THAT WILL BE USED DURING THE OPERATION.
WHERE THE LEADER WILL BE DURING THE OPERATION AND WHERE THE NEXT HIGHER LEADER WILL BE.

The most important part of receiving an order is knowing what the unit has to do in respect to the area and the supported unit. The chances of success are reduced unless the

leader knows exactly what he is supposed to do, what other units are doing, and where and when these actions are to be done. After hearing the entire order, don't leave until all of the questions have been answered.

As soon as the order is received and the commander's plan is understood, take a few minutes to go over the notes that were taken. Think about the order and ask these questions —

- What *mission(s)* was received?
- What is known about the *threat*?
- How does the *terrain* and *weather* influence the operation?
- What *supplies or equipment* are needed? Are any *special tasks* assigned to anyone?

Mission. Identify exactly what the unit is to accomplish. Be sure to know how much time is required to prepare. Are there any restrictions or special tasks that apply to the platoon or section?

A thorough understanding of the mission will allow the leader to make a time schedule for required preparations. The platoon/section leader will be told what time the operation is to begin and when the platoon/section must be ready to go. He should identify the things that must be done, then work backwards from the "ready" time to allow the troops time to finish each task. This technique is called the "reverse planning sequence."

Threat. Develop the best picture of the Threat:

- Where he is located.
- What his strength is.

- What type of weapons and equipment he has.

This applies equally to the ground and air threat. Tell the troops as much as you know about how to destroy the kind of enemy you are likely to meet.

Sometimes the enemy will use the same pattern over and over in a certain area. For example, if the enemy has been conducting ambushes around road junctions, tell the troops about it.

Terrain and Weather. Most decisions on routes, sectors of fire, primary target lines, team positioning, and movement depend on the terrain. Study every bit of ground to properly employ men and equipment and gain an advantage over the enemy. Proper use of terrain will provide cover and concealment before, during, and after the operation; increase the effectiveness of Stinger fire; and decrease the effectiveness of enemy fire.

Take into consideration how weather can influence the operation. Cold, heat, rain, or snow can create problems if men and equipment are not prepared. Also, certain weather conditions can lower Stinger effectiveness (refer to chapter 5).

Supplies, Equipment, and Special Tasks. Consider the mission to be accomplished. Does the unit have the right kind of supplies and equipment? If the mission requires a special skill, such as tactical air movement, be sure to know how to do it. If help is needed, or if something is needed for the operation, but is unavailable, tell the leader/commander.

RECONNAISSANCE, SELECTION, AND OCCUPATION OF POSITION

Stinger units will be continually moving, whether employed in forward or rear areas. The section must move often to perform its mission and survive on the battlefield.

Reconnaissance, selection, and occupation of position (RSOP) must be part of every unit's SOPs. SOPs for RSOP must be thoroughly understood and practiced

repeatedly by unit personnel. SOPs must cover both day and night movements and occupations of position. They should include loading plans for each of the ways in which the unit can be moved — rail, sea, air (both cargo aircraft and helicopter), and road. The platoon, normally, does not displace by itself. Therefore, this discussion will be limited to RSOP as applied only to the section. The section usually displaces with the supported unit and seldom conducts an RSOP independent y.

THE ROP SEQUENCE

The basic sequence of actions for conducting RSOP is as follows:

- Receive a movement warning order.
- Issue the section warning order.
- Plan the reconnaissance.
- Brief personnel and issue orders.
- Make a ground reconnaissance and select positions.
- Plan and prepare for the occupation.

The time available for RSOP and circumstances under which it is conducted will vary greatly. A section chief will seldom have time to conduct a detailed ground reconnaissance and a methodical occupation of position. Often, time will permit only a hasty map reconnaissance, some quick oral orders, and a rapid displacement to new positions. No matter how abbreviated the RSOP, however, the basic actions remain about the same. The two actions most commonly abbreviated will be the ground reconnaissance and the planning of the occupation.

After conducting a map reconnaissance, the section chief identifies the team primary/alternate positions to an accuracy of about 100 meters. The team chief can then pick the best position within the general area. If a ground reconnaissance is possible, the section chief or his designated representative will normally perform it. The purpose of the ground reconnaissance is to verify the

tentative general positions selected in the map reconnaissance. Team members are not normally taken on the ground reconnaissance unless the section is released from its air defense mission. In this case, the senior team chief is normally left in charge of the section while the section chief conducts the reconnaissance.

If the terrain is particularly difficult or the distance to be traveled long, the section chief should have the teams accompany the supported unit until reaching the new positions to insure air defense coverage during movement. Upon reaching the new positions, he can reposition his teams as necessary to take advantage of the terrain not shown by his map reconnaissance.

A section RSOP may be required for two reasons:

When a Defended Asset or Unit Moves. The reconnaissance party may consist of the section chief and guides from the supported unit. The teams would move with the supported unit providing air defense protection en route. Members of the recon party may be used as guides at the release point to insure a rapid and orderly occupation of position.

As time permits, the section chief and his party make a detailed reconnaissance of each team position as well as his own CP location.

The section chief will brief the guides as to each team's primary sector and primary target line. As the teams pass the release point, they will pick up their guides and move to the selected firing positions. If not already accomplished by the reconnaissance party, each team's primary task is to select the best firing position within the area assigned by the section chief and become operational. In addition, each team will select at least one or two alternate firing positions. As time permits, they will continue to improve primary and alternate positions, digging foxholes, camouflaging, and providing overhead cover.

In this example, the section is given a new mission. The section is to defend a key bridge within a battalion rear area.

In Response to a Change in Mission. This situation requires that the section chief move his section as a unit rather than by individual teams or as a supported unit

movement. First, the section chief issues a warning order to allow his team chiefs to prepare for the movement. Using a map, the section chief normally spots locations for his teams. The section chief selects a route, an assembly area, checkpoints, and release points along the route.

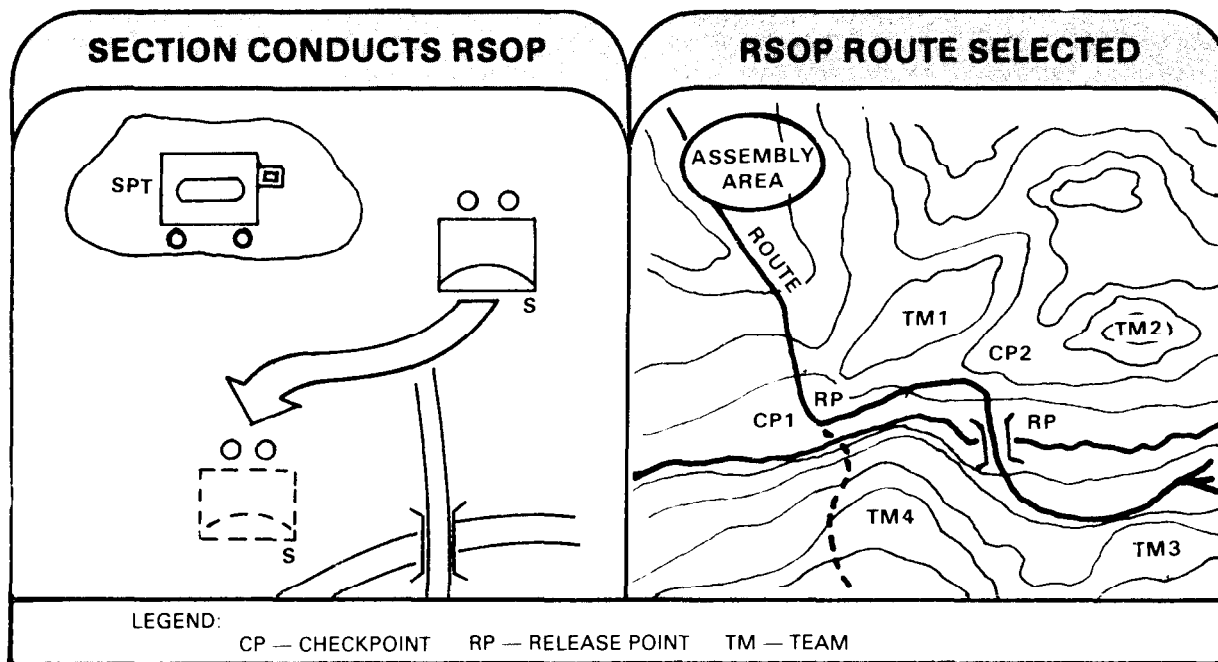

PLATOON OPERATIONS

The Stinger platoon headquarters element is small. It consists of the platoon leader and two other individuals. They are the platoon sergeant and the radiotelephone operator/driver. The element is transported on a ¼-ton truck and trailer. This element is not staffed to operate as a large command post. The platoon leader normally locates his headquarters element in the vicinity of his parent battery. Depending on the tactical situation, the element can collocate with a centralized Stinger section which has good communications. Collocating with a centrally located section can be used to take advantage of additional personnel. For

instance, the platoon leader could leave the platoon sergeant in charge of the element and he could be free to visit his other sections, check on the troop's welfare, supplies, problems, etc. Also, more personnel would be available to man the element.

The platoon leader can locate close to the brigade TOC. At this location, the headquarters element radio can be remoted from the vehicle to the TOC. He can assist the AD coordination officer from the supporting ADA battery to the TOC. This duty can give the Stinger platoon leader first-hand information on the air battle. The platoon

radio must be monitored at all times, even if the teams are on standby.

The platoon headquarters monitors the operational state of all sections by radio. The platoon headquarters maintains a Stinger situation map and overlays, and monitors the position and engagement reports of its sections. Personnel and equipment losses are monitored and reported to higher headquarters. The platoon headquarters monitors missile expenditure and

coordinates missile resupply within the supported maneuver unit. If necessary, the platoon headquarters may have to reallocate existing missile stocks between sections. The platoon headquarters assists its sections in resolving any unforeseen problems which the section cannot handle.

Air defense priorities within the supported maneuver unit are frequently reexamined to accommodate any change in plans and unit losses.

PLATOON HEADQUARTERS INTERNAL OPERATIONS

For Stinger platoon day-by-day operations, some simple yet effective procedures may be used to keep the commander posted on the air defense situation. The platoon leader should be prepared to brief his commander on all air defense matters pertaining to the force whenever called upon to do so. In turn, he must also attend briefings on operations and intelligence so that he knows what the unit is doing. He should also keep the platoon sergeant abreast of the tactical situation and any on-going activities.

communications with Stinger sections, and supervising the training of Stinger sections.

Radiotelephone Operator/Driver. The radiotelephone operator (RATELO)/driver is required at the platoon and section levels. This position requires an experienced individual to operate the command net station and monitor the C/V command net radio and early warning net. He transmits time-critical air defense information to the sections when other personnel are absent or asleep. The platoon headquarters radio must be monitored 100 percent of the time.

PLATOON HEADQUARTERS PERSONNEL

The platoon leader has the platoon sergeant and the radiotelephone operator/driver to assist him.

Platoon Sergeant. The platoon sergeant is the senior noncommissioned officer assigned to the Stinger platoon. The platoon has a very complex command and control problem for a unit of its size. The platoon controls a total of 18 teams operating in a large part of the division area. Some of the platoon sergeant's responsibilities and tasks include, but are not limited to: assisting the platoon leader in planning and conducting the defense of the supported unit against low-altitude air attack, establishing and maintaining

OPERATIONAL AIDS

Several operational aids may be used by headquarters element personnel to assist them in their daily operations.

Air Defense Status Chart. The operating status of the Stinger section and other pertinent data are maintained to provide a ready source of information for the headquarters personnel. A commander may want to look at the chart at any time, so it must reflect current status. The use and design of the chart will vary with the individual platoon. This chart could be mounted on a small board and covered with acetate. It does not have to be elaborate. In fact, the status can be shown on a sheet of paper as shown in the example.

★EXAMPLE

AIR DEFENSE STATUS CHART

AD WARNING: RED
DTG: 072526Z

WEAPONS CONTROL STATUS: WEAPONS FREE
DTG: 072526Z

ELEMENT	LOCATION	CALL SIGNS	STATES OF READ-INESS	MISSION	SUPPORTED UNIT AND CALL SIGNS	MSLS ON HAND	FAAR LOCATION & FREQUENCY	REMARKS
A SECT	66855485	B2G60		DS	1-76 C3D41		6685 5485 CHANNEL 1	
TEAM 1	66825765	B2G61	BS			6		
TEAM 2	68205650	B2G62	BS			6		
TEAM 3	69006995	B2G63	BS			6		
TEAM 4	70455542	B2G64	BS			6		
TEAM 5	68105530	B2G65	M			6		
B SECT	1825094	B2G70		GS	3-76 C4E51		7080 4900 CHANNEL 2	
TEAM 1	71555456	B2G71	STBY			6		
TEAM 2	72695380	B2G72	STBY			6		
TEAM 3	71795328	B2G73	STBY			6		
TEAM 4	71185256	B2G74	M			6		
TEAM 5	73505276	B2G75	OA			6		
C SECT	75554810	B2G80		GS	3-76 C5F61		7600 4700 CHANNEL 6	
TEAM 1	75255086	B2G81	BS			3		
TEAM 2	76315015	B2G82	BS			6		
TEAM 3	77404935	B2G83	BS			6		
TEAM 4	74404965	B2G84	BS			6		
TEAM 5	75544929	B2G85	BS			6		

LEGEND:

BS - BATTLE STATIONS
STBY - STANDBY
M - MAINTENANCE

OA - OUT OF ACTION
DS - DIRECT SUPPORT
GS - GENERAL SUPPORT

GS-R - GENERAL SUPPORT-REINFORCING
ATCH - ATTACHMENT

Operations Overlay. An operations overlay can be fabricated by superimposing a locally devised coordinate system on acetate over an operations map. An operations overlay of this type can be used for airspace coordination purposes so that the platoon leader can determine which Stinger teams are affected by friendly aircraft flights. The operations overlay for the platoon need not

be elaborate. An overlay normally shows locations of friendly units, boundaries, control points, coordinating points, objectives, directions of attack, axes of advance, and routes of march.

Stinger weapon positions are plotted on the operations overlay. The overlay should be classified according to the SOP.

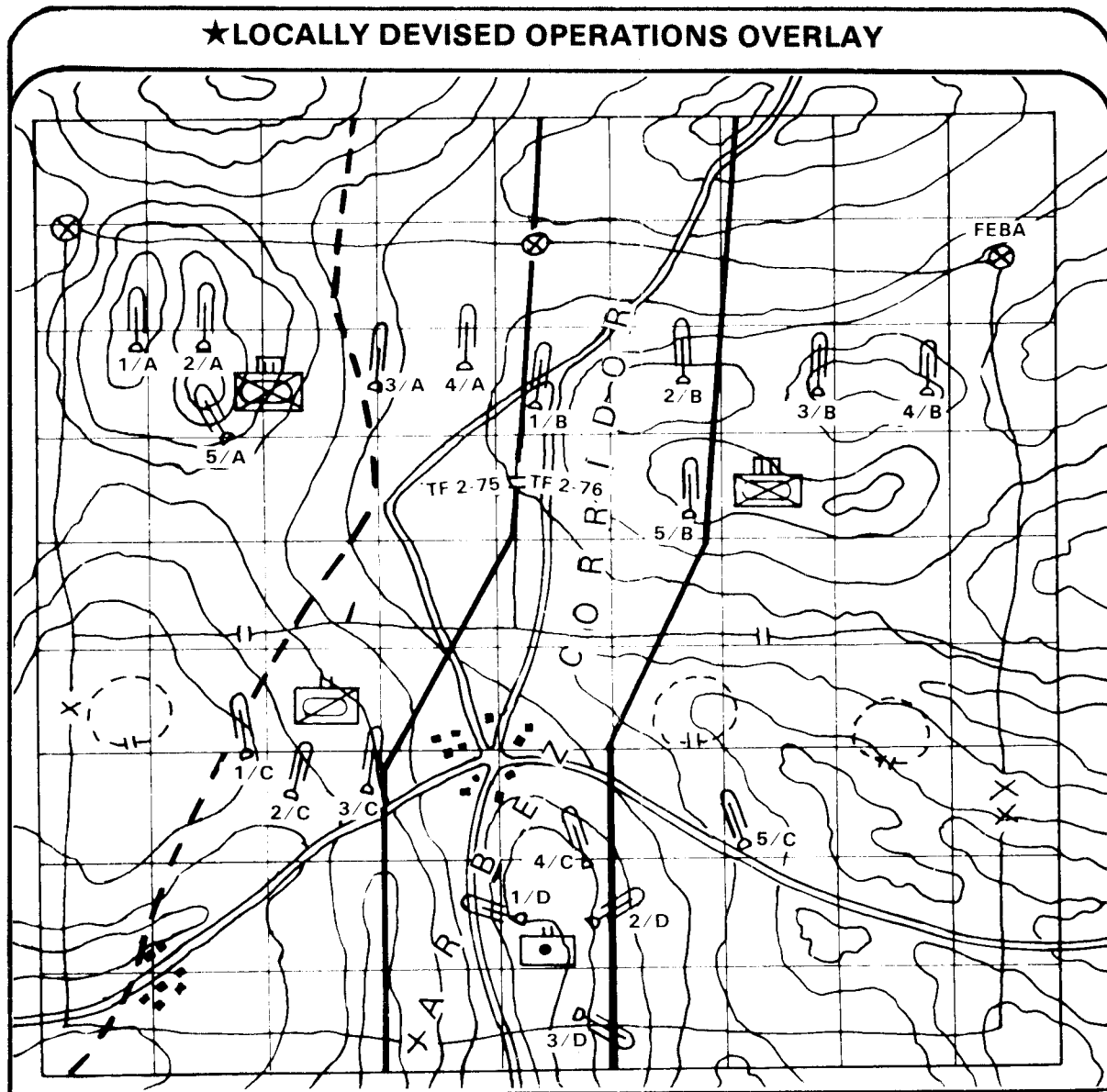

Journal of Events. The Stinger platoon headquarters should maintain a journal of events which reflects important actions concerning the platoon. States of alert, changes in weapons control status, etc., should be recorded. Entries should be simple and direct and need not be typed. Some units may require only that the Stinger platoon

contribute entries to the unit's staff section journal. In any event, the Stinger platoon CP should operate in concert with the commander's or S3's directives in this matter. Sample entries are shown. (Detailed information pertaining to journals and workbooks is found in FM 101-5.

SAMPLE DAILY STAFF JOURNAL ENTRIES					
DAILY STAFF JOURNAL			PAGE NO: 1		NO OF PAGES: 2
ORGANIZATION STINGER PLATOON			FROM		TO
			0001	21 NOV 82	2400 21 NOV 82
ITEM NO.	TIME		INCIDENTS, MESSAGE, ORDERS, ETC.	ACTION TAKEN	INIT
	IN	OUT			
1	0905	0911	WEAPONS HOLD; 1400-1430 HR	DISSEMINATED TO TEAMS ALPHA AND BRAVO.	OFV
2	1205	1209	TEAM DELTA REPORTS ENEMY JAMMING	REPORT FORWARDED TO BATTERY COMMANDER.	

INTELLIGENCE

Stinger personnel must take the initiative to obtain all information concerning the enemy air threat, the terrain, and the weather. Much intelligence information is disseminated from the division to brigade and from the brigade to the battalion. This information is available to the battery command post. Pertinent intelligence should be passed on to Stinger platoon personnel as required.

Some of this information is gleaned from order of battle manuals, captured maps, situation reports (SITREPS), aerial photography, weather reports, etc. The

platoon coordinates with the supported unit's intelligence section daily for updated intelligence and maps. Each Stinger section and team must have a map of the area in which they are operating.

Threat Air Intelligence. Threat air intelligence will come down to the platoon from the battery CP. The platoon leader will forward pertinent information to the sections. The platoon leader may also visit the battery CP to obtain specific information. In the case of nondivisional Stinger units, the Stinger platoon leader may contact an air defense command post such as the C/V command

post for this information, if time and distance permit. The Stinger teams need to know the composition of the air threat for aircraft recognition purposes. They must know as much as possible about enemy aircraft they will encounter and any new variations of ground attack techniques which may develop. A list of enemy aircraft is developed by intelligence agencies and provided through air defense channels to assist in identification after hostilities commence.

Periodic updating of information pertaining to these aircraft will better prepare Stinger personnel for combat. Even during combat operation, the Stinger platoon leader must continue to reinforce aircraft recognition skills of Stinger personnel during inactive periods.

Terrain and Weather. Terrain and weather affect Stinger operations. For example, terrain that affords good observation and long fields of fire favors the use of attack helicopters by the enemy. Stinger personnel

must become adept at map reading and recognizing masked locations from which hostile aircraft/helicopters may launch surprise attacks. Weather conditions affect Stinger operations to a considerable degree. Stinger effectiveness is degraded during certain atmospheric conditions. In general, the higher the humidity, the shorter the range of infrared radiation acquisition. Other particles in the atmosphere, such as dust, smoke, fog, and rain, will absorb and scatter infrared radiation and reduce its acquisition range. Also, these conditions will reduce visual detection and identification ranges which are vital to gunner reaction times during an engagement.

Weather affects all aspects of operations. The Stinger platoon leader must consider not only the effects of weather on his Stinger teams and weapons, but also its effect on air operations and on the terrain. The platoon leader may have to relocate teams in periods of reduced visibility to maintain overlapping coverage.

SECTION HEADQUARTERS INTERNAL OPERATIONS

The Stinger section chief selects the position where the section headquarters is to be located. The section headquarters will be located at some point between the teams and the supported unit CP or the Stinger platoon CP. The main consideration is whether he can effectively command and control the Stinger teams. To accomplish this, he must communicate with each team.

Day-by-day operation of the headquarters element is very similar to that of the platoon headquarters. Many of the control requirements are time critical.

COMMAND RELATIONSHIPS

The section chief positions his teams in accordance with the commander's air defense priorities. If the maneuver unit is

supported by a Vulcan platoon, that platoon leader assumes overall control of ADA resources. In this case, the Stinger section chief assumes the role of a subordinate ADA leader.

HEADQUARTERS PERSONNEL

Section Chief. The section chief directly controls his teams and is heavily involved in air defense planning. He must transmit early warning to the teams, evaluate friendly flight information, and adjust the weapons control status in the affected area. He monitors and evaluates the individual positions of the Stinger teams. He must monitor the current ammunition and fuel status of the teams and keep the platoon leader informed on important supply problems.

The section chief coordinates with company/battery/troop commanders and other leaders on positioning his teams. He coordinates with these leaders on security, rations, medical aid, communications requirements, etc., on a local level.

Also, he must evaluate and forward after-action reports required by the unit SOP.

The section chief may have to reallocate missiles. For example, if one team has expended all its missiles, he may have to

reallocate missiles within the section until resupply is affected.

In addition to these duties, the section chief advises the supported unit on air defense matters including small arms air defense.

Radiotelephone Operator/Driver. The RATELO/driver assists the section chief to operate the section command net and operate the Stinger section headquarters.

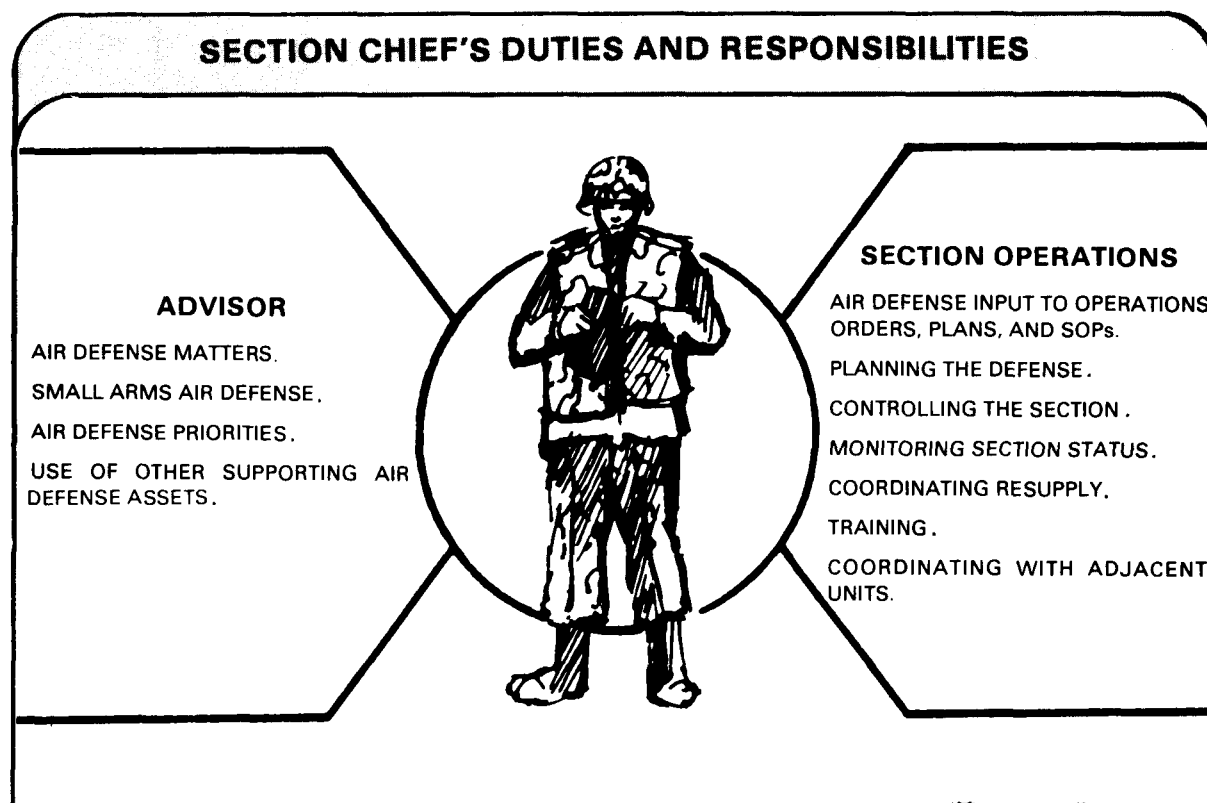

OPERATIONAL AIDS

Operational aids at this level must be small and simple.

Air Defense Status Chart. An air defense status chart at this level must show team

locations and other pertinent information to section operations as shown in the example.

Operations Overlay. An operations overlay can be made similar to the one at platoon level.

★SAMPLE AD STATUS CHART							
AIR DEFENSE STATUS CHART							
A SECTION							
AD WARNING: RED DTG: 072526Z				WEAPONS CONTROL STATUS: WEAPONS TIGHT DTG: 072526Z			
MISSION:							
STINGER TEAM	TEAM LOCATION	CALL SIGN	STATUS	MSLS ON HAND	DTG OF LAST IFF PROGRAMMING	FAAR LOCATION & FREQUENCY	REMARKS
1	66825765	B2G61	BS	6	041800	66855485 CHANNEL 8	
2	68205650	B2G62	BS	6	041930		
3	69006995	B2G63	BS	6	051800		
4	70455542	B2G64	BS	6	051930		
5	68105530	B2G65	M	6	061800		
LEGEND							
BS - BATTLE STATIONS		OA - OUT OF ACTION		GS-R - GENERAL SUPPORT-REINFORCING			
STBY - STANDBY		DS - DIRECT SUPPORT		ATCH - ATTACHMENT			
M - MAINTENANCE		GS - GENERAL SUPPORT					

IFF REPROGRAMMING

The section chief must determine when and where to reprogram the Stinger team's IFF interrogators and recharge the IFF interrogator batteries. This servicing is

based on the tactical situation. He may stagger this operation. That is, he may do this operation for three teams on one day and two teams on another day.

CHAPTER 7

Combat Operations

As a part of the divisional air defense battalion, Stinger is a vital member of the combined arms team.

This chapter focuses on the Stinger section and teams in support of the battalion task force conducting combat operations. The close relationship between Stinger and the supported maneuver unit is magnified by the very real enemy air threat and the requirement for continuous, ready, and effective air defense.

This chapter is not intended to fully inform the reader on the offensive and defensive techniques used by the battalion task force. The leaders of Stinger platoons and sections, however, must thoroughly understand the operations of the battalion task force and the company team to effectively support them.

HOW STINGER SUPPORTS COMBAT OPERATIONS

Stinger is always a defensive weapon, that is, it reacts to the presence of an air threat. Whether defending maneuver units engaged in the offense or in the defense, the key to successful Stinger operations is to establish and maintain positions that will enable Stinger teams to provide protective cover for the supported force. This means that Stinger moves with the force and shifts its positions as necessary to support the force.

The differences then, between Stinger operations in the offense and in the defense lie primarily in the manner the supported force moves in each situation. The offense is fluid. It is characterized by sudden bursts of

movement followed by short halts as contact is made and the battle develops. The tempo of the defense is slower but still involves movement as the supported force advances in preparation for the attack.

In a fluid situation, teams move and position themselves relative to the supported unit to maintain covering fires. On occasion, the section chief will be unable to position his teams. Therefore, the teams position themselves relative to the element of the force they are assigned to support. The teams will keep the section chief informed of their locations. If the tempo of the action is slower, the section chief retains positioning control of his teams.

CONTENTS

	PAGE		PAGE
How Stinger Supports Combat Operations ..	7-1	Stinger Support in the Defense	7-4
Stinger Support in the Offense	7-2	Dismounted Operations	7-5

STINGER SUPPORT IN THE OFFENSE

When maneuver units begin an offensive operation, they must give up their covered and concealed positions, attracting the attention of the enemy. Therefore, moving units are extremely vulnerable to air attack. For this reason, these maneuver units are normally accorded a higher priority for air defense than they would be in a defensive posture.

TYPES OF OFFENSIVE ACTIONS

The battalion task force will participate in many different types of offensive operations. Each of these combat activities require changes in the manner in which Stinger is deployed and employed. Operations commonly conducted include:

- Movement to contact.
- Attacks - hasty and deliberate.
- Exploitation and pursuit.

Movement to Contact. Movement to contact is a tactical maneuver to gain or regain contact with the enemy. Units moving to contact move in a traveling configuration, traveling overwatch or bounding overwatch. The method used depends on the probability of contact with the enemy. Traveling is used

in the initial phase of the operation when no contact with the enemy is expected. The unit shifts to traveling overwatch as the probability of contact increases and to bounding overwatch when contact is imminent.

Defense of the unit in the traveling technique is similar to the defense of a convoy. Stinger teams are integrated into the column, and firepower is concentrated at the head and tail of the column.

Stinger teams move out of the column path and dismount to engage attacking aircraft.

In the traveling overwatch, the unit slows down and moves in long bounds with an overwatch element providing covering fires over the bounding element. Stinger teams should be used with both the bounding and the overmatching elements. The teams with the overmatching element are positioned to provide coverage over the bounding element while it moves forward. The teams with the bounding element stop and dismount to engage attacking aircraft but their purpose is to establish forward positions to cover the trail element as it moves up.

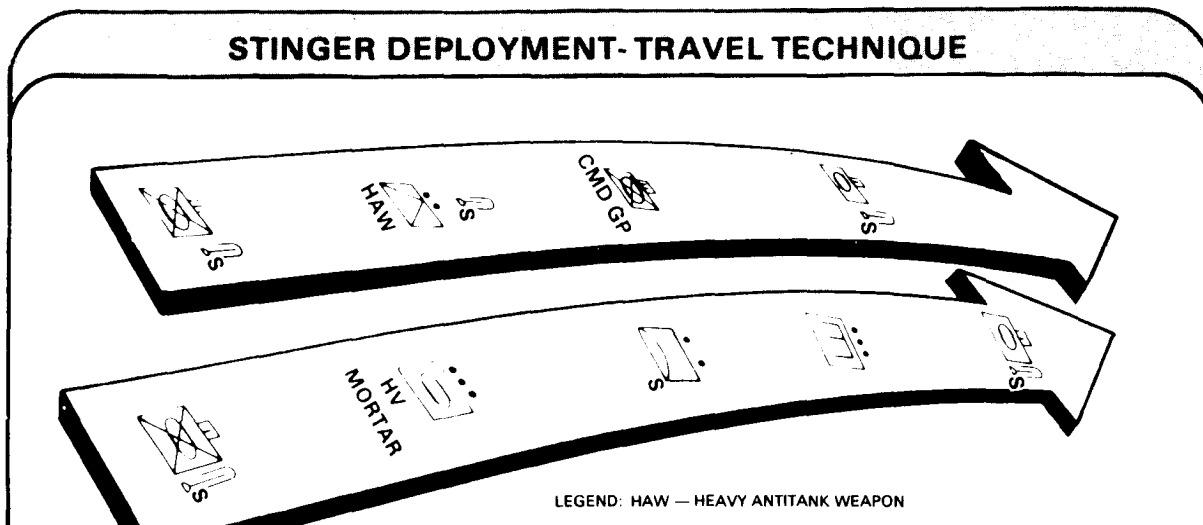

The bounding overwatch is characterized by short spurts of movement, making maximum use of cover and concealment. The lead unit moves under the protective fire of a trail overmatching unit. In this situation, the length of the bound is such that Stinger can cover the bounding element from the overwatch position. When the lead unit completes its bound, it provides cover as the trail unit with accompanying Stinger moves up.

If only one Stinger team is available, the team will normally remain with the overwatch element.

If two Stinger teams are available, one team will remain with the overwatch elements. The other Stinger team should accompany the bounding element. When the bounding element becomes the overmatching element, its Stinger team will be ready to fire.

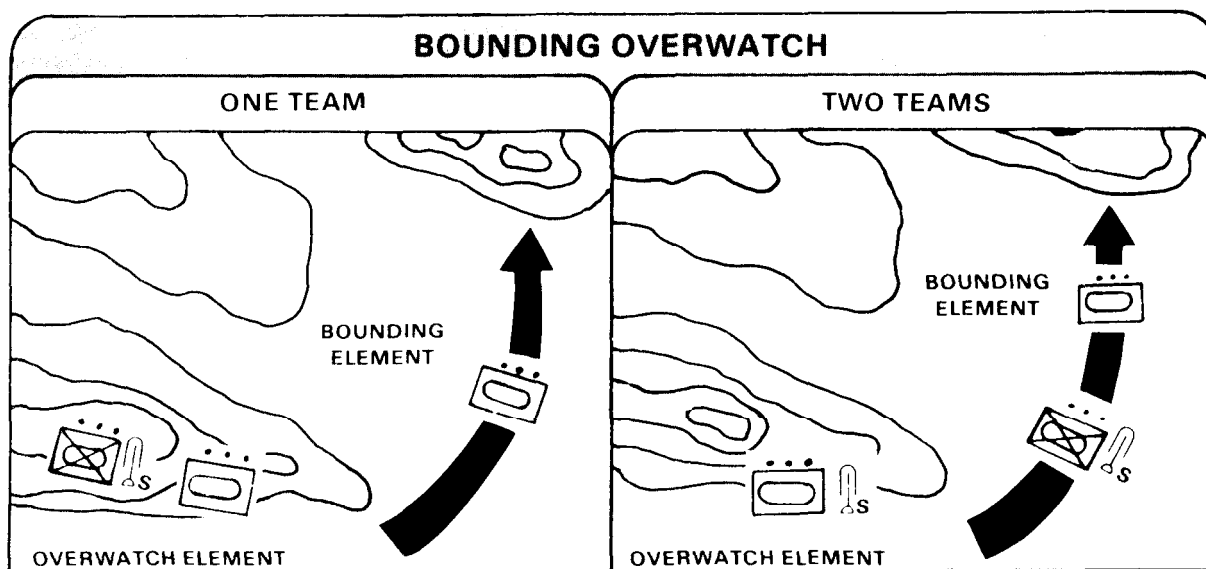

Attacks — Hasty and Deliberate. When the task force does gain or regain contact with the enemy, one of several actions may be taken. One company team may fix the enemy force with fire while the remainder of the task force bypasses it. The task force may conduct a hasty attack using fire and maneuver to neutralize or destroy the enemy and continue the attack. If strongly defended positions are encountered, the task force may stop, regroup, and mass for a deliberate attack to penetrate and break through into the enemy's rear area. When contact is gained, fire and maneuver may be used. Movement is similar to bounding overwatch, coupled with

controlled and directed fires against the enemy position.

The basic guidelines for Stinger teams supporting the bounding overwatch also apply during the attack.

Exploitation and Pursuit. An exploitation is undertaken to follow up success in the hasty or deliberate attack. This consists of a series of movements to contact and hasty attacks characterized by speed and violence. Once the enemy is in full retreat, the battalion task force executes a pursuit to overtake and destroy the retreating forces.

The same basic guidelines for Stinger teams supporting the bounding overwatch also apply during the exploitation and pursuit.

PLANNING FOR THE ATTACK

Normally at battalion level, Stinger support is planned and controlled by the section chief. Support is based on the battalion commander's priorities. The Stinger leader works closely with the battalion S3. Two factors, mobility and vulnerability, are critical considerations when planning support of an offensive operation. The team's organic vehicle is the ¼-ton truck. It may be unable to keep up with armor or mechanized infantry forces in some instances. When planning support of an operation, the section chief must recognize that his mobility problem may increase as ordnance litters the battlefield.

The Stinger teams will be more vulnerable to enemy direct and indirect fire than the armored or mechanized units they are supporting. This is true because Stinger must be fired from an exposed position. Also, the vehicle is not armored. These factors must be taken into account when planning an operation.

Flexibility and coordination are the keys to a successful plan. Once contact is made with the enemy, the battalion task force commander may have to shift units rapidly. Little or no time will be available for additional planning. The flexibility of the initial plan will determine how well Stinger teams continue to support the mission after contact. The Stinger section and teams must continuously coordinate with supported units, who insure that their units do not outrun or fall behind air defense coverage.

The Stinger section chief will normally receive a warning order prior to an offensive operation. This warning order can contain information such as the time of attack, mission, and objectives. It can also contain administrative instructions and employment plans for battalion elements. The section chief then issues a warning order to his teams. Additional information required to support his plan must be obtained from the supported unit.

Air defense priorities will be provided to the section chief with the warning order. After developing his plan, the section chief must get the battalion commander's approval through the battalion S3.

STINGER SUPPORT IN THE DEFENSE

The overall system of ACTIVE defense is based on the rapid movement of forces. These forces concentrate against the enemy's main thrust once it is identified. Battalion task forces then engage the enemy attack with all available firepower. The friendly forces use the advantages of terrain and prepared firing positions. As the attacker is defeated, forces are shifted to new positions or reoccupy old ones.

The battalion task force may be employed in a variety of situations in the conduct of the ACTIVE defense. At division level, the battlefield is normally organized into three areas: covering force area, main battle area, and rear area.

COVERING FORCE AREA

Forces in this area are deployed to find the enemy. They fight him with sufficient force to cause him to reveal the location of his main effort. Battalion task forces make up the covering force. They fight from a series of covered and concealed battle positions — engaging when the enemy cannot return effective fire. They then move on order to new positions and engage the enemy again.

Priority of air defense for a battalion task force in the covering force area (CFA) will normally go to the exposed and vulnerable company teams. Each company team should be supported by one or more Stinger teams.

The teams will be positioned to provide overmatching of units as they move from position to position. Remaining teams will be employed to protect logistical elements and other assets.

In the CFA, passive air defense measures of camouflage, dispersion, night displacement and resupply, and reduced size of CPs contribute to the effectiveness of air defense.

MAIN BATTLE AREA

The main battle area (MBA) begins at the forward edge of the battle area and extends to the rear boundaries of the forward brigades. Forces in the CFA delay the enemy and make him deploy. Then the battalion task forces are shifted in the MBA. Battalion task forces may concentrate on a series of successive battle positions in order to destroy the enemy in the main battle area.

In the main battle area, when the battalion TF is in the defense, the priorities of air defense will shift. The shift is from company teams more toward fire support, command and control, and logistical assets of the battalion. Company teams in good defensive positions are not as vulnerable as some other battalion elements. Typical priorities for Stinger support might be: heavy mortar, supporting tanks and antitank weapons (such as TOWs), trains, and TOC areas.

In the MBA, Stinger teams should be deployed behind the FEBA to protect the flanks and rear of the battalion task force from air attack. Stinger teams may occupy

preselected positions which are planned for as much overlapping coverage as possible. Usually, they provide air defense protection from overmatching positions. As a general rule, Stinger units will overwatch their supported units from high, accessible terrain that provides the best fields of view, communications, and command and control.

★ When a battalion task force is directed to shift to concentrate against the enemy main thrust in another brigade area, Stinger priorities would again change. Company teams moving on road networks provide lucrative targets for air attack. Stinger teams are integrated into each company's march column to provide air defense. A company team using open roads and moving a considerable distance may have two or more Stinger teams allocated to support it.

★ The Stinger section chief is located where he can best control the section. The teams begin movement when friendly elements begin movement. If a team is accompanying a maneuver element, the team chief selects the best positions en route to the new area.

★ When supporting a maneuver unit in defense, Stinger leaders must be aware of all the ground tactical aspects of the defense; the section chief must decide what to do in any given situation. For example, when a battalion task force is disengaging, the section chief must be prepared to rapidly change Stinger coverage to comply with new priorities.

DISMOUNTED OPERATIONS

Stinger is assigned to all types of divisions, separate brigades, and regiments. Regardless of their mode of transportation, at times Stinger teams will have to abandon their vehicles and operate dismounted. While Stinger teams operate most effectively with their organic equipment, they must be

prepared to support maneuver units under all tactical and terrain conditions.

A Stinger team without organic transportation to carry team equipment or the basic load of Stinger weapons is severely limited as to firepower, communications, and mobility.

★ OFFENSIVE OPERATIONS

Generally, the types of offensive operations conducted by foot mobile troops are similar to those previously explained for the battalion task force in offensive operations. During the attack, within battalions, companies use bounding overwatch and fire and maneuver.

Stinger teams provide support by moving and positioning themselves relative to the element of the force they are assigned to support.

★ When planning to move Stinger teams dismounted during an attack, extensive coordination is required. The commander may decide to provide assistance to Stinger teams to hand carry additional Stinger weapons to insure an adequate supply of weapons. When dismounted, because of weight limitations, the team is limited to carrying only two Stinger weapons. In addition, a team radio (manpack), extra BCUs, individual weapons, binoculars, etc., must be carried. Providing assistance to dismounted Stinger teams to carry extra Stinger weapons will enhance the sustainability of air defense for the supported unit. To aid the section chief in planning, a sample march-load and weight allocation table of Stinger team equipment is shown in FM 44-18-1.

Equipment remaining behind must be safeguarded. Arrangements must be made to bring this equipment forward as soon as the tactical situation permits.

The section chief should plan for resupply of missile rounds as required.

★ DEFENSIVE OPERATIONS

Dismounted troops are used in built-up areas or in rugged, broken, or heavily wooded terrain which restricts mounted movement. Dismounted troops in the defense do not move rapidly. Stinger positions are preselected as much as possible before teams move into them. Stinger positions are chosen with the idea of obtaining overlapping coverage. Again, when maneuver units displace in the defense, Stinger teams move and position themselves relative to the supported force.

★ During defensive operations, Stinger teams positions must include overhead protection. Alternate fighting positions should always be constructed.

★ STINGER IN AN NBC ENVIRONMENT

Stinger teams will fight essentially the same in a nuclear environment as in a conventional environment. Combat service support and communications may be disrupted more than in a conventional environment. Teams may also be isolated for extended periods of time. Otherwise, conventional team tactics are unchanged for use in a nuclear environment.

Complete descriptions of how Stinger personnel operate, survive, and fight in a nuclear environment are found in FM 44-18-1.

★ CHAPTER 8

MANPAD Defense in Non-ADA Units

MANPAD systems are allocated to non-ADA units to provide self-defense protection against air attack. This need has developed because of the improved capability of threat air forces to destroy our maneuver units. MANPAD systems in the self-defense role can be used to protect these non-ADA units when they are displacing, traveling in a convoy, or during other critical periods when the units come under air attack. This chapter discusses how MANPAD systems are employed, in general terms, to protect these units from air attack. For detailed employment doctrine and weapon handling techniques refer to this manual and FMs 44-18-1, 44-23, and 44-23-1. Classified weapon system capabilities and limitations and gunner ranging techniques of fire are found in (SNF) FM 44-1A(U).

ORGANIZATION AND EQUIPMENT

Current tables of organization and equipment (TOE) do not authorize MANPAD personnel in non-ADA units. In the base TOE, these units are not authorized communications and other equipment to support the

employment of MANPAD systems as in an ADA unit. MANPAD systems are employed by one soldier rather than as a two-man team found in a typical ADA unit.

CONTENTS			
	PAGE		PAGE
Organization and Equipment	8-1	System Employment	8-3
Command and Control	8-2		

NUMBER OF MANPAD SYSTEMS

The number of MANPAD systems for non-ADA units in the Army of Excellence heavy and light divisions are shown in the following tables.

LIGHT DIVISION		
TYPE UNIT	LEVEL AT WHICH AUTHORIZED	MANPAD SYSTEMS
FIELD ARTILLERY	BATTALION (3)	18
4.2 MORTAR	PLATOON (1)	9
MILITARY POLICE	SQUAD (9)	18
DIVISION HHC	COMPANY (1)	2
BRIGADE HHC	COMPANY (3)	3
TOTAL		50 TEAMS
NOTE: IF THERE ARE FOUR FIELD ARTILLERY BATTALIONS, INCREASE TO 20 TEAMS; TOTAL WOULD BE 52 TEAMS.		

HEAVY DIVISION		
TYPE UNIT	LEVEL AT WHICH AUTHORIZED	MANPAD SYSTEMS
FIELD ARTILLERY	BATTALION (3)	18
4.2 MORTAR	PLATOON (10)	20
MILITARY POLICE	SQUAD (18)	36
DIVISION HHC	COMPANY (1)	2
BRIGADE HHC	COMPANY (3)	3
TOTAL		79 TEAMS

Authorized equipment for the nondedicated gunner is shown in the following illustration.

EQUIPMENT AUTHORIZED FOR NON DEDICATED GUNNER	
EQUIPMENT	QUANTITY
REDEYE WEAPON ROUND	2
REDEYE WEAPON-ROUND CONTAINER	2

COMMAND AND CONTROL

The unit commander retains the responsibility and authority to direct self-defense gunners to engage known enemy targets. Other aspects of control for gunners are the same as used with small unit self-defense against air attack which are described in FM 44-8.

Self-defense gunners do not have equipment to effect access to normal ADA command and control communications channels. Based on their missions, only a simple communications system is required. FM radio, or wire communications between gunners and the unit command post, will serve to transmit necessary command and

control information.

The gunner will fire only in self-defense (WEAPONS HOLD); for example, when fired upon or when the aircraft commits a hostile act. Hostile criteria is found in chapter 3, FM 44-18 and chapter 5, FM 44-23.

SYSTEM EMPLOYMENT

Currently, the MANPAD system which is used for non-ADA air defense employment is the Redeye guided missile system. In this context, the Redeye mission is to provide air defense protection for assets throughout the division area. It will be employed to supplement and enhance local small arms used in the air defense role.

Early engagement should be strived for if the asset is critical to the command or operation. The matter of early engagement is one of judgment on the part of the commander. Early engagement is achieved by placing the gunner out and away from the defended asset. This is accomplished so that the gunner can engage and destroy the target prior to the aircraft reaching the ordnance release line. The gunner cannot accomplish this if he is positioned on, or close to the critical asset, because the advantage of early engagement is negated. Therefore, a fast mover (fighter bomber) can approach the asset and accomplish target destruction before he is engaged due, in part, to the location of the gunner and his reaction time.

Gunners must be provided, whenever possible, sufficient time to ready their weapons. When not alerted they must have their MANPAD weapons close by even when they are performing their own MOS duties. System effectiveness largely depends on gunner reaction time.

It must be remembered that the gunner is not in the ADA command and control loop. He does not know the weapons control status in effect and does not need to. However, he does need to know if an aircraft is performing an attack maneuver. The maneuver may be difficult for the gunner to assess; therefore, he needs to be well indoctrinated in expected threat aircraft tactics.

During convoy movement, the gunners will provide self-defense against enemy air attack. The positioning of MANPAD systems will depend on convoy length and available MANPAD weapons. Convoy protection procedures found in chapter 7, FM 44-18-1 apply. Gunners may be pre-positioned along the route of march to provide air defense at key points such as choke points and bridges.

CHAPTER 9

Support of Special Operations

The environment greatly affects combat operations. Operations cannot be stopped because of rain, snow, ice, extreme heat, lack of water, or rough terrain. Certain areas of the world combine one or more of these conditions. These environments present special problems to military operations. In this chapter, four environments most commonly encountered are described. They are mountains, jungles, deserts, and northern environments.

In addition to fighting in these environments, certain types of operations require special planning and tactics. Chief among these are airborne, air assault, night, and river crossing operations and operations in urban terrain. This chapter describes these types of operations and how Stinger can be used to support them.

MOUNTAIN OPERATIONS

Mountains of military significance are generally characterized by rugged, compartmented terrain with steep slopes and few natural or man-made lines of communication. The weather is usually seasonal varying from extreme cold to warm temperatures. Rapid, drastic changes in weather are not unusual in mountainous terrain. The wind can also pose a problem. In cold weather, the wind chill factor significantly increases the chance of frostbite. Winds are accelerated when forced over ridges and peaks or when converged through passes and canyons.

Above an altitude of 2,500 meters, acclimatization is required. Acclimatization is complete only when personnel realize their limitations and the limitations imposed on their equipment. After months in a high-

altitude environment, 70 percent of sea level work capacity standards can be achieved. The effects of high altitude on unacclimatized personnel are increased errors in performing simple mental operations, decreased ability for sustained concentration, deterioration of memory, decreased vigilance, increased irritability, and self-evaluation impairment.

There are several health hazards that exist in mountainous climates.

SNOW BLINDNESS

Because of the rarified atmosphere at high altitudes, more direct sunlight reaches the earth than at sea level. In the snowy conditions common in mountainous areas,

CONTENTS

	PAGE		PAGE
Mountain Operations	9-1	Airborne and Air Assault Operations	9-7
Jungle Operations	9-3	Operations at Night	9-10
Desert Operations	9-3	Military Operations in Urban Terrain	9-10
Northern Operations	9-5	River Crossing Operations	9-11

snow blindness can become a problem. Snow reflects about 75 percent of the sun's rays. This, coupled with the increased intensity of the sun's rays, can overload the eyes. Snow blindness is usually temporary. However, personnel with severe cases may be completely disabled for several days. Snow blindness can be prevented by using snow goggles or sunglasses which completely cover the eyes.

FROSTBITE

Frostbite is a constant hazard when the wind is strong because of the wind chill factor. The face, especially, must be protected from high winds and prop blast. Sweating excessively must be avoided. The buddy system is essential when the danger of frostbite exists.

SUNBURN

In the rarified atmosphere at high altitudes, sunburn can be a problem. A serious case of sunburn can disable a person for several days.

DEHYDRATION

Although normally associated with desert climates, dehydration can occur in mountainous climates as well. Personnel often will not drink as much water as they need. Use of fruit flavoring often helps. Leaders must, however, monitor their personnel closely for any signs of dehydration.

Mountainous terrain offers unique challenges to military operations. Some of the physical characteristics of this environment which affect operations are rugged peaks, steep ridges, deep ravines, and valleys; limited routes of communication; highly changeable weather; and the availability of natural cover and concealment.

Control of the heights is important to successful mountain operations. Mobility is

another prime consideration. Because of terrain and, in some cases, weather, obstacles and barriers assume added importance.

Mountainous terrain offers distinct advantages to attacking enemy aircraft. Aircraft can avoid radar and visual detection by flying at low level through valleys and mountain passes. They strike their targets with little or no warning. Heavy ground forces and combat support and service support units are road-bound, providing lucrative air targets. Narrow mountain roads are often restricted to one-way traffic with no room for passing. One vehicle disabled by an air attack may stop an entire column. It then becomes an open target for field artillery, ground, or follow-up air attack.

Mountainous terrain favors the use of small, lightly equipped maneuver elements. The nature of the terrain will normally afford these elements good cover and concealment. However, they will at times be exposed to air attack. Stinger may be the only air defense weapon that can accompany and provide close-in air defense protection for these units. Dismounted Stinger operations are not uncommon in this environment.

Because of terrain masking of radars and difficulty in establishing line of sight with FAARs, early warning for Stinger teams may be limited. Continuous visual observation must be maintained, particularly along likely low-level air attack routes. Observation posts some distance away from Stinger firing positions may be required for early detection of approaching aircraft.

Stinger sections and teams will rely primarily on radios for communications. Hill masses and forests will degrade distance and quality of FM radio transmission. Use of long-wire antennas and relays can ease this problem.

Reference FM 90-6 for further details on mountain operations.

JUNGLE OPERATIONS

Jungle areas are found in the wet tropics. They generally consist of trees interconnected by a network of thick vines. Jungles do, however, vary greatly within this general description. High temperatures, high humidity, and a heavy annual rainfall create lush vegetation. This can seriously impede movement.

One thing is hard to overcome when preparing for operations in a jungle area. It is the popular misconception in the minds of personnel about the jungle. Most unacclimatized personnel harbor a great fear of the jungle. They see it as a purgatory in the form of large trees, thick brush, swamps, heat, and humidity infested with thousands of animals, snakes, and insects just waiting to get them. This fear can incapacitate some personnel. Fortunately, most eventually see the jungle for what it actually is and learn to function with it. As with any other environment, the jungle serves those who know it best.

There are, of course, unique hazards in the jungle. As with anything else, proper training and precautions greatly reduce these hazards.

Movement either by vehicle or foot is difficult in jungle areas. Minor terrain features can present major obstacles to movement in combination with the dense vegetation. Defensive action in jungle terrain is considerably aided by natural features. Small units are the essential element in all jungle operations.

The dense jungle offers good concealment for maneuver forces. Therefore, enemy air attacks may be directed primarily against combat service support units, supply lines, and exposed field artillery units. However, air attack of maneuver units can be expected when they cross open areas such as rice paddies or rivers.

Stinger firing positions that offer 360° observation and fields of fire will be difficult, if not impossible, to find. Stinger teams defending unit convoys will normally have to be positioned within and move with these convoys. Stinger teams defending stationary assets may have to clear trees and underbrush to have adequate firing positions. These positions should only be occupied to engage aircraft. Then they should be vacated rapidly, as cleared areas are easily detected and attacked from the air.

Jungle conditions tend to reduce detection and identification ranges. This may require teams to be positioned closer together. More teams than usual may be required to defend a particular asset.

Thick vegetation, high humidity, and rugged, hilly terrain will reduce the range of FM radios. Extensive use of wire communications may be necessary. When radio is used, special purpose one-fourth wavelength antennas should be provided.

Rust, corrosion, and fungus growth will require an additional maintenance effort. Repair parts, ammunition, and other items should be kept in sealed containers until they are needed. This will minimize damage from rust and corrosion. Electronic equipment should always be kept on. The heat generated by the equipment eliminates moisture which causes corrosion.

Personnel must be well-trained and acclimated to the jungle environment. Heat exhaustion and jungle diseases carried by insects are common. Proper individual sanitation, wearing of protective clothing, and use of insect repellent will minimize these health risks.

Reference FM 90-5 for detailed information on jungle operations.

DESERT OPERATIONS

While most people see the desert as hot, arid, sandy land, actual conditions vary

greatly. The only common denominator is lack of water. The three different types of

desert are mountain, rocky plateau, and sandy or dune deserts.

Mountain type deserts are characterized by high, steep mountains. When it rains, it generally does so in high areas. This causes severe flash floods. Water from these floods collects in depressions. This water usually evaporates rapidly. In some instances, however, the volume of water entering the depression with each storm exceeds the evaporation rate, and a salt lake is formed.

Rocky plateau deserts are characterized by relatively slight relief interspersed with large flat areas. Rock is usually at or near the surface. Steeply eroded valleys are common. Flash floods often occur in these valleys.

Sandy or dune deserts are extensive, relatively flat areas covered with sand or gravel. Some areas contain sand dunes over 1,000 feet high and 15 to 25 kilometers long. Other areas may be totally flat for distances of 3 kilometers and beyond. As with other types of deserts, flash floods may be a problem. Rain in mountains can cause flash floods for hundreds of miles. High winds and dust storms are also common to these areas.

Water, of course, can be a major problem in any desert area. In desert areas with high temperatures, a resting man may lose as much as a pint of water per hour. Sweating may not be noticeable as it evaporates so fast that the skin may appear dry. To retain sweat on the skin, which aids in cooling the body, personnel must remain fully clothed.

Day/night temperature fluctuation can exceed 70° F in some areas. It is vital that leaders check their personnel to insure that they have all the equipment they will need prior to starting a mission. The wide dispersion of units common in desert warfare also places a great deal of responsibility on junior leaders.

The jungle and desert are very different environments. Although it may seem strange, many of the hazards present in a jungle environment are also present in a desert environment. The same key should be applied in fighting these hazards. The list

includes: dehydration, heat injuries, cold injuries, plague, typhus, malaria, dengue fever, dysentery, cholera, typhoid, polluted water, loss of mental alertness, and social diseases.

In hot areas, acclimatization will be needed. Two weeks should be allowed with progressive degrees of heat exposure and physical exertion. This will strengthen heat resistance, but it will not totally protect personnel.

The low, flat terrain found in desert areas normally aids Stinger in detection of enemy aircraft at greater ranges. During windy seasons, blowing sand may, however, degrade aircraft detection. Because of a general lack of landmarks such as wood lines, buildings, and rivers, enemy aircraft often will have problems finding and fixing their targets. This may require them to make two passes at a target; one to locate it and a second to attack it. This will greatly improve the chances of a Stinger team destroying the aircraft before it attacks the target.

Low, flat, desert terrain will require forces to disperse to prevent detection and engagement at long ranges. This dispersion aids passive air defense. However, it may cause gaps in defenses where overlapping fires between Stinger teams are not possible.

Covered and concealed positions are difficult to find in the desert. Vehicle tracks leading into firing positions must be erased or covered since they are easily spotted from the air. Since concealment is difficult, Stinger teams should move often. They should move to alternate positions every 1 or 2 hours and after each firing. The dust or sand cloud created by missile backblast may reveal the team's position.

Stinger teams must be able to move rapidly to survive. They must also move to keep up with the high-speed tactics used by mechanized maneuver elements. In most desert environments, track vehicles must be provided to Stinger teams when moving cross-country. The assigned ¼-ton vehicle will often bog down in loose sand or rocks.

Fast-moving operations and great distances between units will be found in the desert. These require reliance on radio, as opposed to wire, for communications. Line of sight can usually be obtained. However, lack of moisture and extreme heat may cause FM radio ranges to be reduced by as much as 30 percent. Dipole or other directional antennas should be used where possible to increase range of FM radios.

Dust and sand can be as deadly to equipment as enemy fire. Vehicle cooling and electrical systems are vulnerable to the

extreme heat of the desert. Extra water should be carried on all vehicles. Cooling systems should be checked several times a day. The eroding effects of sand on moving metal parts require more frequent cleaning of individual weapons and equipment air filters. The preventive maintenance effort on all equipment must be increased in the desert.

The Stinger system has been qualified for storage up to 160° and operation up to 140° F.

Reference FM 90-3 for detailed information on desert operations.

NORTHERN OPERATIONS

The area of northern operations is generally defined as the area lying north of the temperate zone. The boundary is irregular because of the many factors influencing climate in a given area. In general, the farther north from this boundary the harsher the climate.

As a minimum, harsher winters and milder summers will be encountered. In the far north, permafrost is encountered. In this area, the ground never fully thaws. This can be one of the trickiest areas in which to stage operations. The chart summarizes the environment which can be expected in the different seasons.

The most suitable time for conducting ground operations is from mid-winter to early spring before the breakup period. During this period, the ground remains frozen allowing greater mobility. Care must be taken with operations in the late spring or in the fall. They should only be undertaken when daytime thaw and nighttime freeze leave only a thin layer of mud on deeply frozen ground.

Vegetation varies from thick evergreen trees to moss and lichens. Forests are usually found closer to the temperate zone. Moss and lichen are usually found in permafrost areas. In summer in permafrost areas, vegetation may mat together over a pool of water. This is

called a bog. The matted vegetation may support a man but will not support any type of vehicle. These areas can be extremely dangerous.

There are certain unique weather conditions that are common in the northern environment.

NORTHERN ENVIRONMENT	
SEASON	CONDITIONS
SUMMER	LONG DAYLIGHT. MUD/DUST. SWAMPS IN PERMAFROST AREAS. RELATIVELY MILD TEMPERATURES.
WINTER	LONG NIGHTS. EXTREME COLD. ICE/SNOW. STRONG WINDS.
FALL	VARYING TEMPERATURES.
SPRING	MORASS (SWAMPS) OF MUD.

WHITEOUT

Whiteout is a milky atmospheric condition in which the observer appears to be surrounded by a uniform white glow. Shadows, the horizon, or clouds are not discernible. Whiteout is experienced in the air as well as on the ground. The observer's sense of depth and orientation is completely lost.

GREYOUT

Greyout occurs over unbroken snow at twilight or when the sun is close to the horizon. The observer is surrounded by an overall greyness. When the sky is overcast, shadows cannot be seen, leading to a loss of depth perception. The difference between this and whiteout is that the horizon can be seen, so orientation is not completely lost. The effect of greyout is greatest when a person is fatigued.

ICE FOG

Ice fog occurs around inhabited areas at temperatures below -35° F. Air at that temperature cannot hold the water vapor created by human activity. The excess water vapor freezes into ice particles and creates a fog.

Perhaps the greatest danger to personnel in a northern area comes from the cold. Special clothing is required for both wet and dry cold. Bare hands will stick to metal and fuel in contact with the hands will result in supercooling. If this occurs, the hands can be painfully frozen in seconds. The buddy system is essential in this environment. Overdressing may cause as many problems as not wearing enough clothes. Exhaustion is common in cold climates, especially when operating at high elevations.

Stinger teams operating in extreme cold should hold their breath during and after firing. The exhaust from the missile may crystallize into a form of ice fog. If this fog is inhaled, toxic fumes may thaw out inside the lungs causing injury or death.

Several factors must be taken into account when planning military operations in a northern area. Mobility may be a

problem. Momentum is difficult to achieve and easily lost. Requirements for heat will place a premium on fuel. Ice fog and tracks in snow can make camouflage difficult. Blending of features, lack of navigational aids, fog, and blowing snow make navigation difficult. Permafrost makes digging in positions extremely difficult. Night operations are the rule rather than the exception.

Conditions which tend to restrict movement on the ground have little or no effect on enemy air operations. Roads, hills, and rivers found in northern regions provide good navigational aids for enemy aircraft. Road-bound maneuver and support units are easily detected and attacked from the air.

Heavy snow in the winter and poor ground conditions in other seasons may require units to move on foot. Accompanying Stinger teams will be limited to one missile per team member. Other members of the unit may carry additional missiles for them. Resupply may have to be made by air.

Missile warm-up time will be increased. The wearing of bulky, heavy clothing and gloves will increase the time necessary to perform the engagement sequence. Proper training in operations in cold environments will reduce this time.

Extreme and prolonged cold has an adverse effect on all weapons and equipment. Sluggish operations, malfunctions, and broken parts are common. Additional time should be provided to perform preventive maintenance. Extreme cold can more than double the time it takes personnel to perform even the simplest maintenance task. Special attention must be paid to batteries. In extreme cold, batteries have decreased power levels and drain more quickly.

The Stinger weapon system has been qualified for storage to -50° F and operation to -40° F.

Reference FM 90-11 for detailed information on northern operations.

AIRBORNE AND AIR ASSAULT OPERATIONS

One phase of operations ends when the force conducting either an airborne or an air assault operation is on the ground. The principles and guidelines for the employment of Stinger are essentially the same as for other operations. One major factor sets these operations apart, as far as Stinger employment is concerned. This factor is the phasing of units, Stinger teams, and other air defense support into the objective area. Command and control relationships between Stinger teams and supported units must be clearly defined. This is modified, as necessary, as the operation progresses.

AIRBORNE

In a typical airborne operation, each battalion secures a drop zone. Each battalion

then develops its portion of the airhead. In the initial phase, a maneuver company from each battalion makes a parachute assault to secure a drop zone. Then the remainder of the battalion is dropped.

The initial phase is decentralized and the situation is likely to be very fluid. This is true until the entire battalion is on the ground. The Stinger section chief attaches his teams to the maneuver companies during the assault. Stinger thus provides air defense for the maneuver companies as they develop the airhead. Stinger team members do not jump with weapon systems. The weapon systems are palletized and dropped separately.

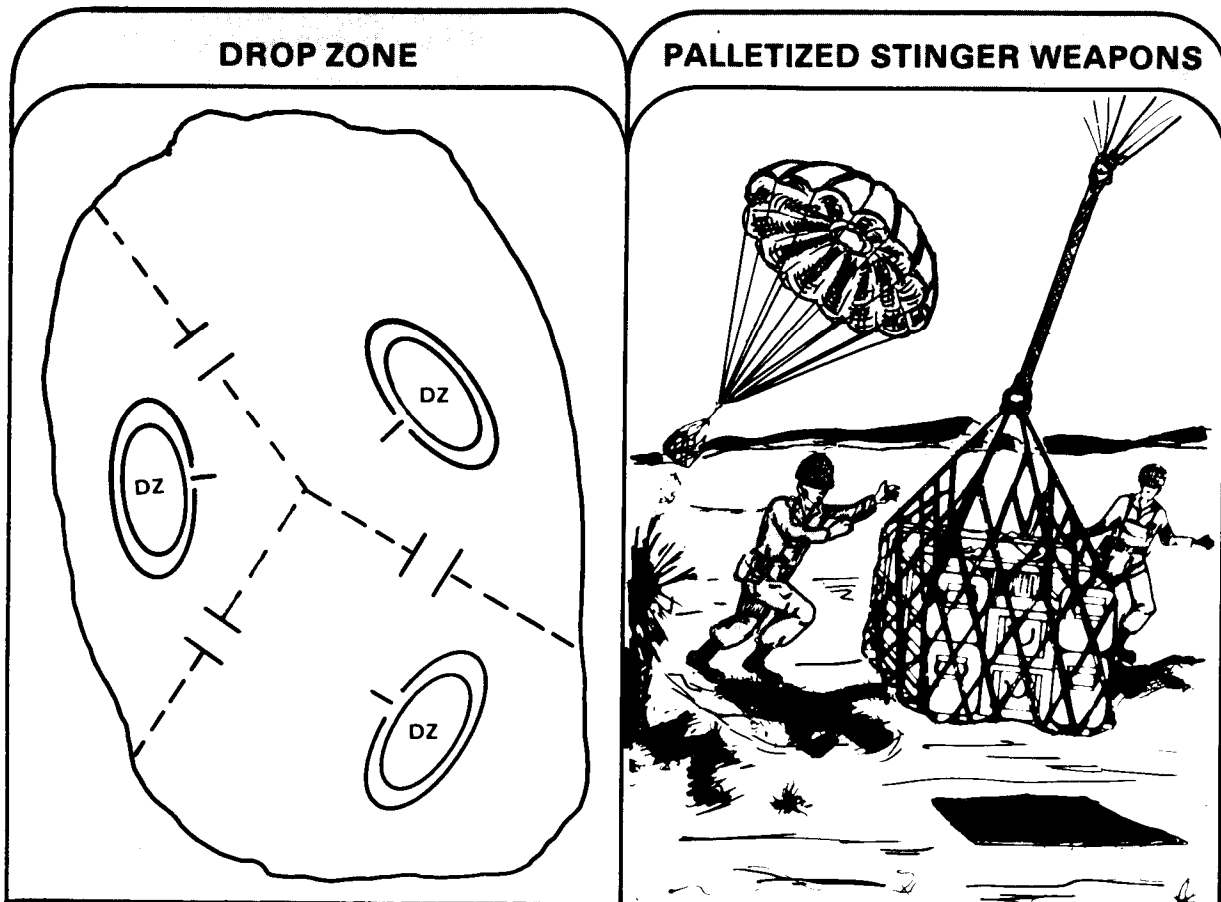

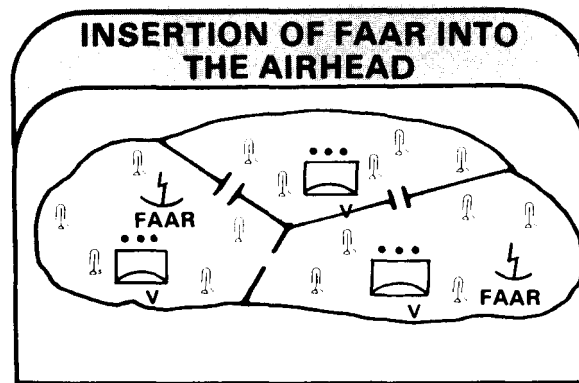
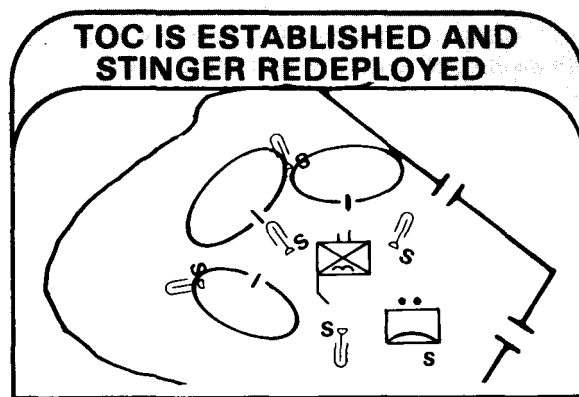
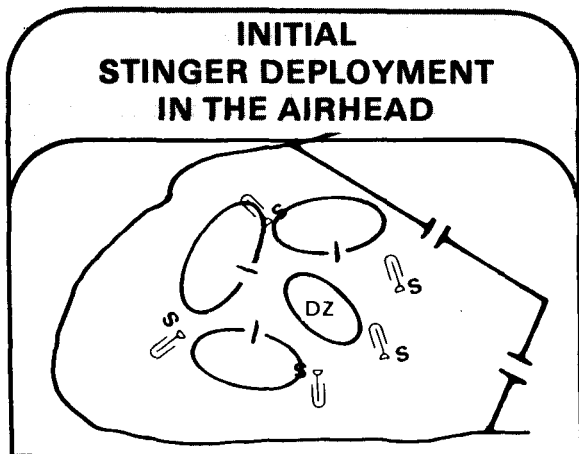

Once the battalion is on the ground, it establishes a TOC. The Stinger section chief then assumes control of his teams and coordinates the air defense of the battalion. Stinger teams previously attached to maneuver companies are relieved from attachment. They are redeployed as required to support designated battalion priorities as the airhead is established and expanded.

With the establishment of an airhead, the brigade is able to insert additional combat support and combat service support elements. These are needed to sustain combat power. As a part of the follow-up echelon, other air defense weapons may be air-landed.

A towed Vulcan battery is usually attached to the brigade for insertion into the airhead. Along with its three Vulcan platoons, the battery may have two FAARs. However, the FAARs may not be inserted into the airhead for several days and Stinger teams will have to operate without TADDS.

The Vulcan battery is responsible for providing air defense information to the Stinger sections. The Stinger section chief enters the Vulcan battery command net and forwards early warning and other air defense orders and information. Information received from the Vulcan battery is relayed to Stinger teams over the Stinger command net. When Vulcan and Stinger are supporting the same company, Stinger teams operate in the Vulcan platoon net. They receive air defense orders and information over this net. When required, the Stinger section chief may pass orders and information to the Stinger team(s) through the Vulcan platoon net.

Reference FM 7-30 and 71-101 for detailed information on airborne operations.

AIR ASSAULT

A typical air assault operation is of battalion size. The air assault task force (AATF) will initially move to covered and

concealed holding areas. These will be in proximity to primary and alternate pickup zones (PZ). Stinger teams are attached to

companies or, if necessary, platoons. Generally, two teams will go in the first helicopter to help secure the landing zone (LZ). The other teams follow later.

The teams are dependent upon the supported unit for assistance in carrying the extra Stinger missile rounds. They are provided no vehicle, and therefore are dependent upon the supported unit for mobility. Mobility for the section equipment and Stinger rounds is provided by a 1¼-ton truck and ¼-ton trailer.

Upon landing, troops disembark as rapidly as possible. They immediately move into tactical formations. Stinger teams remain attached to companies. Stinger teams immediately provide air defense of the LZ as subsequent lifts of troops and equipment are brought in.

Once on the ground, the AATF masses its combat power to engage in ground combat and attack its objective. The Stinger section chief assumes control of his teams. He also coordinates the air defense of the AATF. Stinger teams previously attached to the maneuver companies are relieved from attachment. They are then redeployed as required to support the AATF's priorities as it maneuvers to attack its objective.

The operation may be expanded with the insertion of additional maneuver and support elements, to include Vulcan units and FAARs. Control and coordination links similar to those used in the airborne operation are then established.

Reference FM 90-4 for detailed information on air assault.

REMEMBER

ONCE THE AIR ASSAULT FORCE IS ON THE GROUND, PRINCIPLES AND GUIDELINES FOR STINGER EMPLOYMENT ARE AS DISCUSSED IN CHAPTER 5.

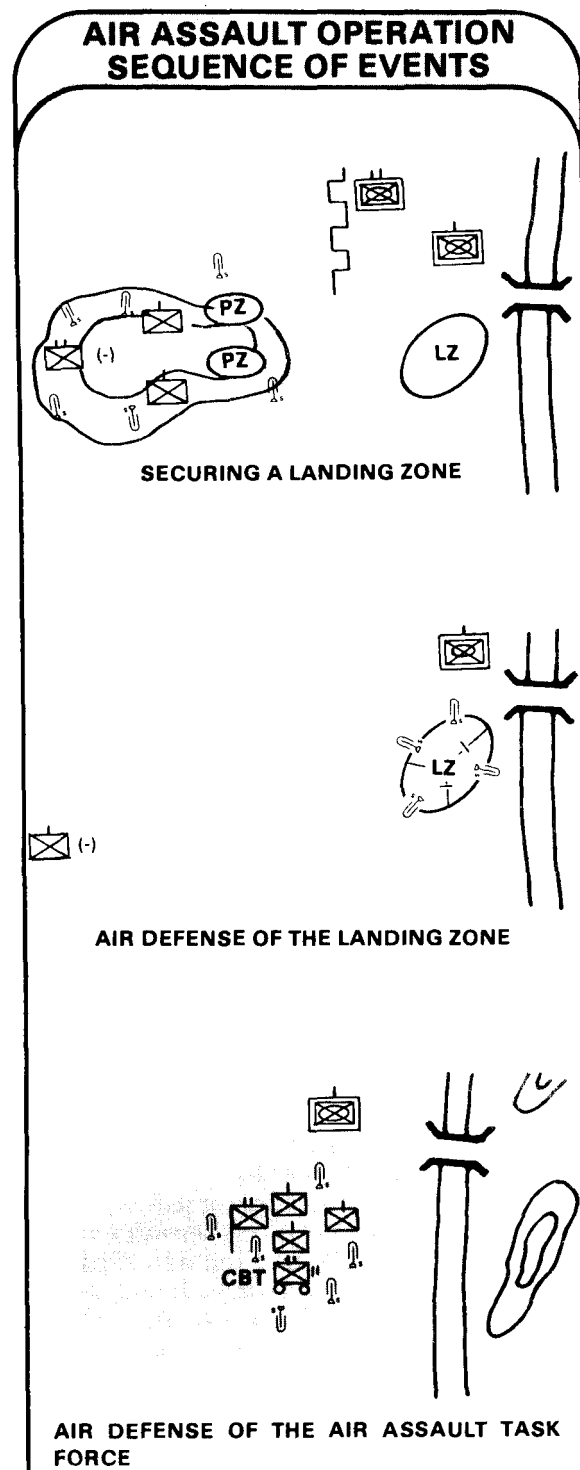

OPERATIONS AT NIGHT

During hours of darkness, the Stinger team's ability to perform its mission is severely handicapped. Fortunately, the air threat is not as great at night. However, the threat of nighttime attack by helicopter assault forces cannot be ignored. Visual detection, visual identification, and determining the range of an aircraft are difficult, if not impossible. In addition, the Stinger team consists of only two men. Thus, it is not manned for 24-hour operation. The section can perform only a limited air defense mission at night: a self-defense role, when the defended unit or asset is under air attack, or if a higher air defense authority declares Weapons Free during hours of darkness.

★ The Stinger team has a limited capability against jet aircraft at night. However, the team has a much better chance of engaging a slower moving aircraft such as a helicopter. Target detection is very difficult even when stars are visible. The gunner attempts to pick up the sound of the aircraft to determine its position and direction. When he hears the noise, the gunner points the sight at the noise source and activates the weapon. The gunner attempts to acquire the target at this time even though he cannot see it. He moves the weapon line of sight until he

receives ir acquisition signals (ir tone) indicating that the seeker has acquired the target. He maintains track and uncages the gyro. After uncaging, their tone gets stronger and louder. The gunner fires when he senses that the target is within range. The gunner does not make a range ring-target size estimation. If he cannot see the target, he does not apply superelevation and lead. If he can see the target, he should apply superelevation and lead prior to firing.

Stinger teams normally use the hours of darkness to move, rest, resupply, and perform maintenance on their equipment. They may be supporting a unit in a static position or a stationary asset. At nightfall they normally move from air defense firing positions to positions affording better security against ground attack (e.g., within the perimeter of the supported unit).

★ If supporting a unit that is moving during the night, Stinger teams normally move with the unit. Remaining within the unit's formation provides for Stinger security. Before first light, the teams deploy to air defense firing positions. They are then ready to engage aircraft as soon as visibility permits. Stinger in night operations is further discussed in FM 44-11.

MILITARY OPERATIONS IN URBAN TERRAIN

The battalion task force will often have to fight as part of a larger force. This may be in villages as a separate force or in towns and small cities. The defender has the advantage in built-up areas. He has instant fortified positions, good cover and concealment, and a detailed knowledge of the terrain. Where possible, built-up areas will be bypassed and isolated by attacking forces.

★ Because they are difficult to identify and hit, targets for enemy aircraft are few. City fighting is normally conducted at very close

ranges. The attacker usually attempts to clear the enemy from built-up areas one building at a time. Coordination for close air support by jet aircraft, because of the closeness of enemy and friendly units, is difficult. Enemy attack helicopters may be used to attack exposed vehicles. They have the ability to pop up from behind obstacles to engage targets and then hide behind buildings.

When supporting company teams fighting in urban terrain, Stinger teams take

up firing positions on rooftops. As company teams move through the built-up area, some of the Stinger teams remain in position. Meanwhile, others move to take up new firing positions on other rooftops. They maintain continuous overwatch against the air threat. Small arms and machine guns supplement

Stinger in defending the company teams when this occurs.

Reference FM 90-10 for detailed information on military operations in built-up areas.

RIVER CROSSING OPERATIONS

River crossings can be conducted to continue an attack as a part of a delay or withdrawal. River crossings can also be used to concentrate forces for another offensive or defensive operation. A battalion task force normally crosses a significant river obstacle as part of a brigade, division, or corps level operation.

A strong and well-planned air defense is necessary for a successful river crossing operation. A mix of ADA weapons — Chaparral, Vulcan, and Stinger — is employed in mass to protect crossing sites.

★ If all company teams are crossing at the same time, each should have dedicated Stinger support. The Stinger teams support the assault elements from good positions on the near side of the river. They cross after the assaulting elements have extended their bridgehead.

★ Priority for the Stinger section will normally be the units making the assault. Stinger elements are deployed with the assaulting elements and should be included in the early crossing forces.

★ Vulcan platoon may remain with the battalion task force as it continues the combat operation. Chaparral platoons will then be brought forward. They support the crossing of the rest of the brigade or division. Stinger teams will again be deployed with company teams when all elements of the task force have completed crossing the river.

From positions to the rear, Hawk units provide continuous overmatching coverage during the river-crossing operation.

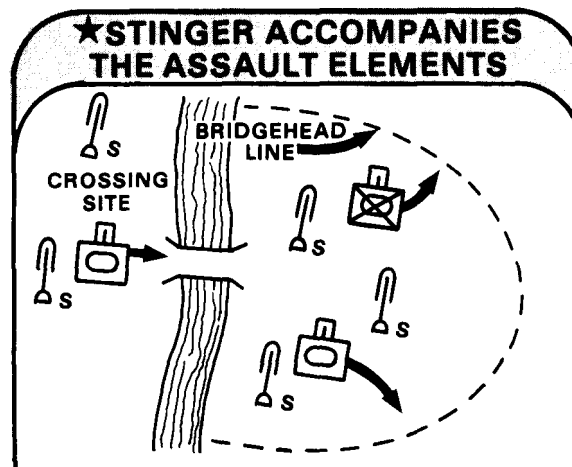
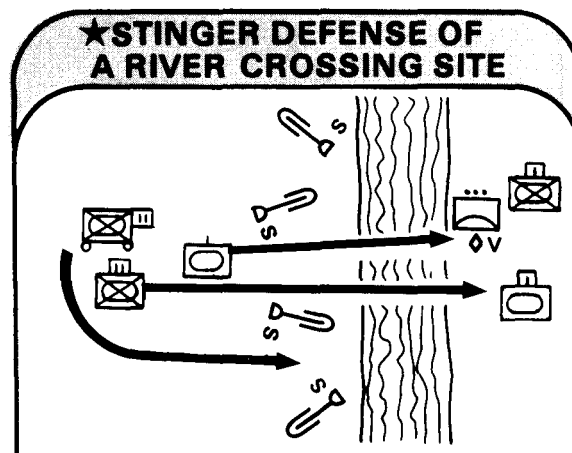

★ The following illustration shows a Vulcan gun battery-in support of a brigade in

the crossing. The integrated Vulcan/Stinger defense is shown below.

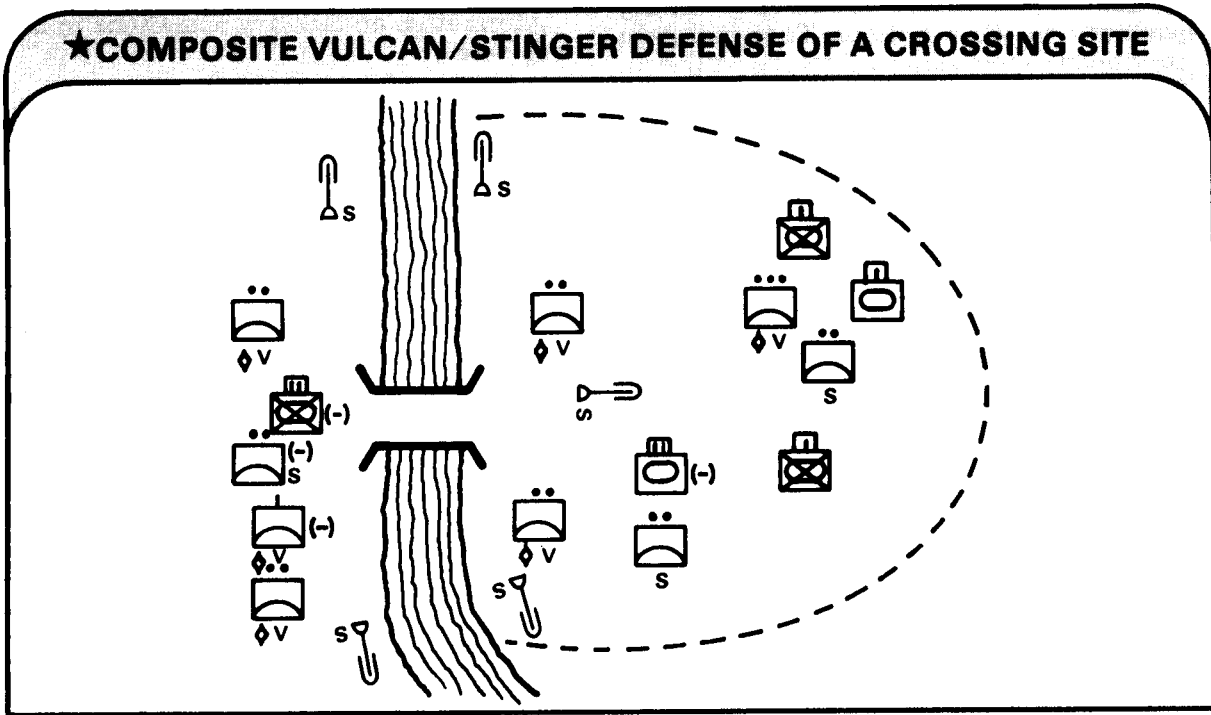

★ As elements of the brigade expand the bridgehead, the Vulcan battery commander moves additional elements of the battery to

thicken the defense of the crossing site and also to support the forward maneuver elements.

CHAPTER 10 Combat Service Support

Combat service support (CSS) is that support provided to a unit from outside sources. This chapter describes how Stinger platoons and sections are provided the supply, maintenance, medical, and administrative support necessary to sustain them in combat. Except for the performance of operator maintenance and IFF reprogramming, the Stinger platoon has no capability to provide combat service support to its teams. This responsibility must be assumed by the parent ADA battery. Stinger personnel must be fully aware of the procedures to follow, so that requests for and distribution of supplies and maintenance support are handled routinely and without delays.

CSS must begin with the actions of the platoon leader, platoon sergeant, and section chiefs. They must know the status of vehicle, and Stinger maintenance; of the supply of rations, ammunition, equipment, and POL in the platoon. Also, they must know the personal needs of their men. They must do all within their capabilities to improve conditions in these areas and seek assistance from the battery commander, XO, and first sergeant. Overall responsibility for platoon CSS belongs to the platoon leader.

STINGER-PECULIAR ITEMS

The Stinger weapon system is simple to maintain. Operator and organizational maintenance have been kept to a bare minimum. The requirements include visual inspection of system-peculiar equipment and correction of minor faults. Specific requirements can be found in TM 9-1425-429 12. The TL-29 electrician's knife is the only tool issued to Stinger personnel. Certain repair parts are necessary to perform operator/organizational maintenance. These are maintained in the prescribed load list (PLL) of the unit to which Stinger is assigned.

WEAPON ROUND/MISSILE ROUND

★ Both the weapon round and missile round are certified rounds of ammunition and each is sealed in a launch tube. Maintenance of certified rounds consists of the

replacement of minor exterior components, visual inspection of the exterior for damage, and visual inspection of the humidity indicator for excessive moisture.

No special maintenance is required to make the missile itself work. As long as the round is sealed, there is no exterior damage, and the humidity inside the sealed launch tube is at the correct level, the round should function properly.

Damage on the exterior of the launch tube or a bad humidity reading may be noted. If so, the referenced TM should be consulted to determine if the round should be turned in for a new one. The same applies to the separable gripstock assembly which is part of the weapon round.

A weapon round may malfunction during an engagement. In this case, both the missile round and the gripstock must be

CONTENTS			
	PAGE		PAGE
Stinger-Peculiar Items	10-1	Supply	10-3
Common Equipment	10-3	Other Logistical Support	10-3

considered unserviceable. The weapon round is a controlled item and every effort should be made to turn it in to the ammunition supply point (ASP), if the situation allows. If the weapon round is destroyed, the serial number should be recorded and reported through command channels. The missile round can be exchanged for a new one at the ASP. It can also be exchanged at the theater depot where the theater stock is located. In most cases, some missile rounds will be present at the ASP to insure ease of supply. The gripstock assembly may be exchanged for a new one at the missile support unit (MSU) or the post/station maintenance support unit. This unit is usually in the division rear area. All exchanges are governed by the direct exchange (DX) procedures in AR 710-2.

In some cases, the Stinger section may be supported by the rocket and missile support teams, rather than an MSU. This unit consists of ordnance detachments in a cellular organization. The entire unit or detachments of the unit may be found at theater, corps, or division level. This depends on where requirements exist. The section leader must determine which type of unit supports him and where it is located. He must do this before the need to exchange items arises.

SHIPPING AND STORAGE CONTAINERS

Operator and organizational maintenance consists of visual inspection and correction of minor faults. Again, TM 9-1425-

429-12 should be consulted to determine if the containers should be exchanged or repaired. Containers which cannot be repaired at the organizational level should be returned to the ASP with the weapon. A new container/weapon combination will then be issued.

BATTERY/COOLANT UNITS

During peacetime, BCUs will be sample tested by a quality team from CONUS. This quality team will replace faulty BCUs. BCUs used in the field that do not activate will be discarded. Those BCUs which have been expended will also be discarded. Inactivated BCUs will be turned into the ASP for return to the supply system.

IFF SYSTEMS

Unserviceable IFF programmers and interrogators will be exchanged at the MSU. The Stinger section maintains operational float interrogators for exchange with the teams.

TADDS

Nonoperational TADDS will be returned to the MSU for exchange.

TRAINING EQUIPMENT

Faulty training equipment (Training Set, M134 and field handling trainers) will be exchanged at the MSU. Limited organizational maintenance is authorized.

The following chart summarizes maintenance support for Stinger-peculiar items.

STINGER-PECULIAR MAINTENANCE SUPPORT		
ITEM	OPERATOR/ORGANIZATIONAL MAINTENANCE AUTHORIZED	EXCHANGED AT
GRIPSTOCK ASSY	YES	MSU
MISSILE ROUND	YES	ASP
CONTAINERS	YES	ASP
BCU	YES	NA
IFF SYSTEM	YES	MSU
TADDS	YES	MSU
TRAINING EQUIP	YES	MSU

COMMON EQUIPMENT

COMSEC

Although not Stinger-peculiar items, COMSEC equipment does require maintenance support. The Stinger section headquarters will perform operator maintenance required by the appropriate TMs. Some items may require additional maintenance. These will be evacuated through normal signal COMSEC channels to a maintenance facility.

OTHER COMMON EQUIPMENT

Operator and organizational maintenance required on other common equipment will be performed by the Stinger section/teams. Maintenance support for these items will normally be provided by the supported unit.

SUPPLY

The supplies most often needed by the platoon are food, fuel, ammunition, and spare parts.

Maintaining an adequate level of supplies within the platoon is mainly a matter of timely request for resupply. If the platoon leader waits for ammunition levels and other basic loads to become very low before requesting resupply, then the platoon will not have enough. Resupply and refueling must be accomplished at every opportunity.

Supplies for Stinger sections will be handled through the S4 of the parent unit. In rare instances, a section may be attached to another unit, or may be deployed in a manner that is not supportable by the parent unit. If this occurs, provisions for maintenance and logistics support should be made by the commander assigning the mission.

As mentioned previously, ammunition resupply is usually available at an ASP.

However, in some theaters, it may be necessary to go to a theater depot.

If avoidable, Stinger sections should not have section personnel or vehicles ferry parts or transport supplies. This is because of the limited number of personnel and vehicles in a section. Doing so may degrade the section's capability to perform its air defense mission or to react to a change in mission.

Other classes of supplies are provided to the Stinger platoon by request from the platoon leader to the battery supply sections located in battalion trains. Stinger teams supporting companies, batteries, or troops request rations, POL, clothing, spare parts, and personal health items through that unit's supply section. The Stinger platoon leader/section chief will prearrange this support when he orders his teams to support these units.

OTHER LOGISTICAL SUPPORT

The platoon leader makes recommendations to the battery commander for promotions, awards, and disciplinary actions. He promptly reports casualties and other losses. Personnel services — leaves and passes, command information, postal service, religious activities, exchanges, financial services, legal services, welfare, bath and laundry services, and rest and relaxation — are designed to help

commanders maintain morale. The platoon leader is responsible for having these services fairly and impartially provided to his soldiers.

★ Medical support for the Stinger platoon is provided by the parent medical section. However, depending on the situation, the platoon leader may arrange for the medical support from the unit being supported.

Administrative support is provided by the parent battalion/squadron S1 sections. The parent battery of the Stinger platoon will handle most of the routine administration pertaining to Stinger personnel.

Logistical support for nondivisional Stinger platoons will be handled by their parent organization.

The platoon leader's problems of insuring continuous CSS for his unit is compounded when his sections are deployed. Sections at different locations may be separated by considerable distances. Experience has shown, however, that all these problems can be overcome through careful planning and coordination.

★ APPENDIX A

References**REQUIRED PUBLICATIONS**

Required publications are sources which users must read to understand or to comply with FM 44-18.

FIELD MANUALS (FM)

44-18-1 Stinger Team Operations

RELATED PUBLICATIONS

Related publications are sources of additional information. Users do not have to read them to understand FM 44-18.

ARMY REGULATIONS (AR)

310-25 Dictionary of United States Army Terms
 310-50 Catalog of Abbreviations and Brevity Codes (Available in microfiche)
 710-2 Supply Policy Below the Wholesale Level

FIELD MANUALS (FM)

3-12 Operational Aspects of Radiological Defense
 3-22 Fallout Prediction
 5-20 Camouflage
 5-36 Route Reconnaissance and Classification
 6-20 (HTF) Fire Support in Combined Arms Operations
 7-7 (HTF) The Mechanized Infantry Platoon and Squad
 7-10 (HTF) The Infantry Rifle Company (Infantry, Airborne, Air Assault, Ranger)
 7-20 (HTF) The Infantry Battalion (Infantry, Airborne, Air Assault, Ranger)
 7-30 (HTF) Infantry, Airborne and Air Assault Brigade Operations
 11-50 (HTF) Combat Communications Within the Division
 17-47 (HTF) Air Cavalry Combat Brigade
 17-50 Attack Helicopter Operations
 17-95 (HTF) Cavalry

21-11 (Test)	First Aid for Soldiers
21-30	Military Symbols
21-40	NBC (Nuclear, Biological and Chemical) Defense
21-60	Visual Signals
24-1 (HTF)	Combat Communications
24-18	Field Radio Techniques
24-20	Field Wire and Field Cable Techniques
24-24	Radio and Radar Reference Data
30-102	Opposing Forces: Europe
31-71	Northern Operations (To be revised as FM 90-11)
32-6	SIGSEC Techniques
44-1 (HTF)	US Army Air Defense Artillery Employment
44-1-2	Air Defense Artillery Reference Handbook
44-3	Air Defense Artillery Employment, Chaparral/Vulcan/Stinger
44-8	Small Unit Self-Defense Against Air Attack
44-30	Visual Aircraft Recognition
44-90 (HTF)	US Army Air Defense Artillery Employment, Hawk
71-1 (HTF)	Tank and Mechanized Infantry Company Team
71-2 (HTF)	The Tank and Mechanized Infantry Battalion Task Force
71-101 (HTF)	Infantry, Airborne, and Air Assault Division Operations
90-2 (HTF)	Tactical Deception
90-3 (HTF)	Desert Operations
90-4 (HTF)	Airmobile Operations
90-5 (HTF)	Jungle Operations
90-6 (HTF)	Mountain Operations
90-10 (HTF)	Military Operations on Urbanized Terrain
90-13 (HTF)	River Crossing Operations
100-5 (HTF)	Operations
100-28	Doctrine and Procedures for Airspace Control in the Combat Zone
100-42	US Army/US Airspace Management in an Area of Operations
101-5	Staff Organization and Operations

TECHNICAL MANUALS (TM)

3-216	Technical Aspects of Biological Defense
3-220	Chemical, Biological, and Radiological (CBR) Decontamination
9-1425-429-12	Operator's and Organizational Maintenance Manual for Intercept-Aerial, Guided Missile System: Stinger, Trainer, GM Launcher, Interrogator and IFF Programmer
11-5805-201-12	Operator's and Organizational Maintenance Manual Telephone Set TA-312/PT
11-5805-243-12	Operation and Organizational Maintenance Manual: Telephone Set TA-1/PT
11-5820-477-12	Operator's and Organizational Maintenance Manual: Radio Set Control Groups AN/GRA-39 (A,B)
11-5820-498-12	Operator's and Organizational Maintenance Manual: Radio Set AN/GRC-160

TECHNICAL BULLETIN (TB)

(C) 380-41	Procedures for Safeguarding, Accounting, and Supply Control of COMSEC Materiel (U)
------------	--

PROJECTED RELATED PUBLICATIONS

These are publications that are scheduled for printing. Upon print, they will be distributed automatically via pinpoint distribution and will not be available for requisition from USA Publications Center, Baltimore, MD, until indexed in DA Pam 310-1.

FIELD MANUALS (FM) (Cent)

3-4	NBC Protection (Supersedes TM 3-221 and TC 3-2)
3-5	NBC Decontamination (Supersedes TM 3-220)
3-100	NBC Operations (Supersedes FM 21-40)
(SNF) 44-1A	US Army Air Defense Artillery Operational Planning Data (U)
44-11	Air Defense Artillery Employment, SGT York Gun/Stinger
90-11	Winter Operations (To supersede FM 31-71)

APPENDIX B
Operations Security

Operations security (OPSEC) includes essential security measures. These are used to deny the enemy information about planned, ongoing, and completed operations. Threat forces will use many intelligence sources in an effort to get information. They try to determine the location, capabilities, and intentions of US units. Their sources include ground reconnaissance, aerial reconnaissance, and signal intelligence elements. US forces, including Stinger sections, must therefore use OPSEC techniques and procedures. They try to neutralize the Threat intelligence collection effort. These techniques and procedures include deception, information security, physical security, signal security and electronic counter-countermeasures. This appendix covers OPSEC procedures used by Stinger units.

THREAT INTELLIGENCE COLLECTION MEASURES

The Threat knows that he must first destroy or neutralize our air defenses before he can successfully use his airpower. Air defense suppression is an effort to destroy or reduce the effectiveness of AD weapons so that coordinated air-ground operations can be completed. Before the Threat can attempt to suppress our AD weapons, including Stinger, he must first determine where they are located. He has many methods in which to do this.

HUMAN INTELLIGENCE

Human intelligence (HUMINT) is the use of people to gather information. These people can be members of the local

population, or enemy ground and air observers. They can also be enemy intelligence agents disguised as friendly troops or civilians. Loose talk, information posted on maps and vehicle windshields, and written materials improperly safeguarded are all collected through HUMINT.

SIGNAL INTELLIGENCE

Signal intelligence (SIGINT) is the use of devices to intercept and monitor our communications-electronics (C-E) systems. This includes both radio and radar systems. SIGINT is done in peacetime as well as wartime.

CONTENTS

PAGE	PAGE
Threat Intelligence Collection Measures B-1	Operating on the EW Battlefield B-7
Suppressive Attacks B-3	Communications-Electronics Operating
Radio Electronic Countermeasures B-3	Instructions (CEOI) B-10

PHOTOGRAPHIC INTELLIGENCE

Photographic intelligence (PHOTINT) is the use of photographic equipment aboard airborne platforms to gain information. PHOTINT, to include infrared imagery, is the most widely used detection method. It provides a permanent record of the exact details of an area. It also permits long-term comparisons to find changes in detail. PHOTINT is the most accurate means of pinpointing target locations.

ELECTRONIC WARFARE SUPPORT MEASURES

Electronic warfare support measures (ESM) are one of the three classes of electronic warfare (EW). The other two classes of EW are electronic countermeasures (ECM) and electronic counter-countermeasures (ECCM).

ESM entails the search, interception, identification, and location of C-E emitters. ESM is often confused with SIGINT, which is concerned with monitoring of C-E emitters for intelligence information. ESM, however, is concerned with identifying and locating the emitters, and includes both ground and airborne radio direction finding (RDF).

The enemy can pinpoint radio/radar transmitter locations by using direction finding equipment. The enemy's RDF equipment can locate any radio that transmits. That is, if there is line of sight between the RDF and the radio.

This appendix describes only those aspects of electronic warfare which affect Stinger communications and those OPSEC measures which Stinger personnel can use to operate on the electronic warfare battlefield.

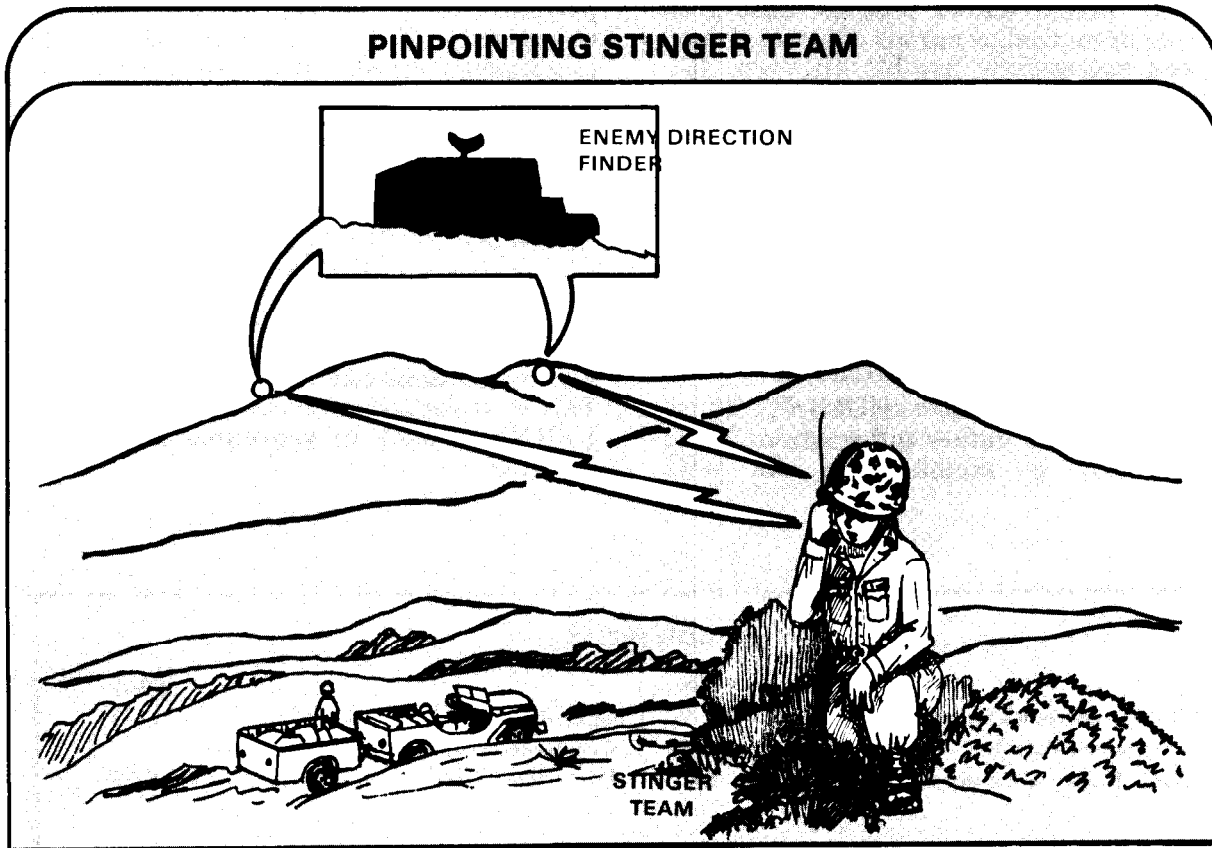

SUPPRESSIVE ATTACKS

After the Threat has located and identified a site, he will try to suppress that site. Remember, AD suppression includes all efforts designed to either reduce AD effectiveness or destroy ADA systems. The Threat will try to do this through physical suppressive attacks and electronic warfare.

The Threat can physically attack an ADA system in three ways —

- Indirect fire. This includes artillery, mortars, rockets, and surface-to-surface missiles. The Threat can use these weapons

to destroy a position without risking his own troops.

Ground attack. The Threat may attempt to destroy a position from the ground by using guerrillas, saboteurs, insertion teams, or other elements operating behind friendly lines.

- Air attack. Finally, the Threat may decide to attack with high-performance aircraft or attack helicopters. These aircraft may use conventional ordnance (bombs, rockets, cannon, or machine gun fire) or precision-guided munitions (smart bombs and ASMs).

RADIO ELECTRONIC COUNTERMEASURES

Electronic countermeasures are all actions taken to reduce an enemy's use of the electromagnetic spectrum. ECM described herein are those applied to radios.

The two ECM means that the Threat will use to do this are deception and jamming. Deception is the introduction of signals into a radio to deceive the operator. Jamming is the introduction of signals into a radio to hide or override actual information.

Once the Threat has a clear picture of friendly communications networks, he will try to enter certain nets disguised as a friendly station. This is known as "imitative communications jamming (ICD)." The Threat will use language experts who speak with the latest slang and accent, and are thoroughly drilled in communications

procedures. ICD agents are good and they are believable. If they are accepted into a Stinger net, they will direct you to fire at friendly aircraft, drive into ambushes, and displace to the wrong position.

All the Threat needs to jam a radio is a transmitter tuned to the frequency of the Stinger net, with enough power to override the signal at the receiver. Threat can use many types of jamming signals against Stinger team radios. The more common of these are described below. Don't try to memorize them; just be aware that they and others exist. When reporting jamming, it's more important to describe it accurately than to identify it by name. Following are types of jamming signals that may be used against you.

TYPES OF JAMMING SIGNALS

Although any transmitter can serve as a jammer, certain types of jamming signals

such as those shown on following pages have been considered more effective.

BABBLED VOICE

THIS SIGNAL IS COMPOSED OF MIXED VOICES ENGAGED IN SIMULTANEOUS CONVERSATIONS, PREFERABLY IN THE SAME LANGUAGE, WITH VOICE CHARACTERISTICS SIMILAR TO THOSE FOUND IN THE VICTIM COMMUNICATIONS NET.

*Signal can also be unintentional.



TO NE

THIS JAMMING SIGNAL IS A SINGLE FREQUENCY OF CONSTANT TONE. IT IS USED TO JAM MANUALLY KEYED MORSE CODE, VOICE, AND RADIO CARRIER CIRCUITS.*

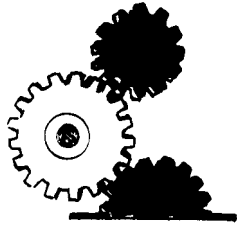

PULSE

THIS SIGNAL RESEMBLES THE MONOTONOUS RUMBLE OF ROTATING MACHINERY. PULSE JAMMING SIGNALS PRODUCE A NUISANCE EFFECT ON VOICE COMMUNICATIONS CIRCUITS.*



RECORDED SOUNDS

ANY AUDIBLE SOUND, ESPECIALLY OF A VARIABLE NATURE, THAT CAN BE USED TO DISTRACT OPERATORS AND DISRUPT COMMUNICATIONS CIRCUITS. MUSIC, SCREAMS, APPLAUSE, WHISTLES, MACHINERY NOISE, AND LAUGHTER ARE EXAMPLES.

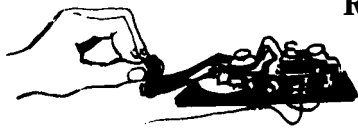

RANDOM-KEYED MORSE CODE

THIS JAMMING SIGNAL IS PRODUCED BY KEYING A MORSE SIGNAL AT RANDOM AND MIXING THE KEYED SIGNAL WITH SPARK NOISE. IT IS EFFECTIVE AGAINST VOICE AND MORSE CODE COMMUNICATIONS.*

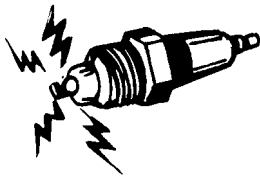

SPARK

THIS SIGNAL IS EASILY PRODUCED AND IS ONE OF THE MOST EFFECTIVE FOR JAMMING. BURSTS ARE OF SHORT DURATION AND HIGH INTENSITY. REPEATED AT A RAPID RATE, THE TIME REQUIRED FOR RECEIVER CIRCUITRY AND THE HUMAN EAR TO RECOVER AFTER EACH SPARK BURST MAKES THIS SIGNAL EFFECTIVE IN DISRUPTING ALL TYPES OF RADIO COMMUNICATIONS.



GULLS

THE GULL SIGNAL IS GENERATED BY A QUICK RISE AND SLOW FALL OF A VARIABLE AUDIO FREQUENCY AND IS SIMILAR TO THE CRY OF A SEA GULL. IT PRODUCES A NUISANCE EFFECT ON VOICE CIRCUITS.

*Signal can also be unintentional.

RANDOM NOISE

THIS IS SYNTHETIC RADIO NOISE WHICH IS RANDOM IN AMPLITUDE AND FREQUENCY. IT IS SIMILAR TO THE NORMAL BACKGROUND NOISE AND CAN BE USED TO DEGRADE ALL TYPES OF SIGNALS; HOWEVER, A GREAT AMOUNT OF POWER IS NECESSARY TO JAM VOICE COMMUNICATIONS.

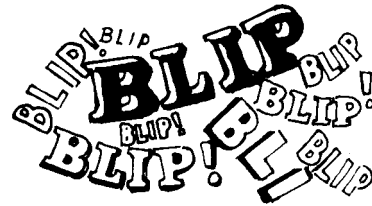

STEPPED TONES

THESE ARE TONES TRANSMITTED IN INCREASING PITCH, PRODUCING AN AUDIBLE EFFECT SIMILAR TO THE SOUND OF BAGPIPES. STEPPED TONES ARE NORMALLY USED AGAINST SINGLE-CHANNEL AM AND FM VOICE CIRCUITS.

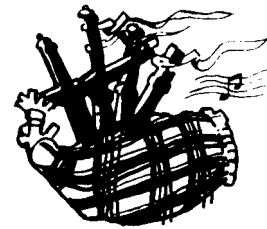

WOBBLER

THE WOBBLER SIGNAL IS A SINGLE FREQUENCY VARIED BY A LOW AND SLOWLY VARYING TONE. THE RESULT IS A HOWLING SOUND WHICH CAUSES A NUISANCE EFFECT ON VOICE COMMUNICATIONS.



RANDOM PULSE

PULSES OF VARYING AMPLITUDE, DURATION, AND RATE ARE GENERATED AND TRANSMITTED TO DISRUPT TELETYPEWRITER, RADAR, AND ALL TYPES OF DATA TRANSMISSION SYSTEMS.

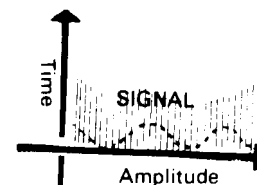

ROTARY

THE ROTARY SIGNAL IS PRODUCED BY A LOW-PITCHED, SLOWLY VARYING AUDIO FREQUENCY, RESULTING IN GRUNTING SOUNDS. IT IS USED AGAINST VOICE COMMUNICATIONS.



JAMMING TECHNIQUES

Jamming is an effective way to disrupt control of the battle.

The enemy normally will employ three types of jamming:

1

SPOT JAMMING

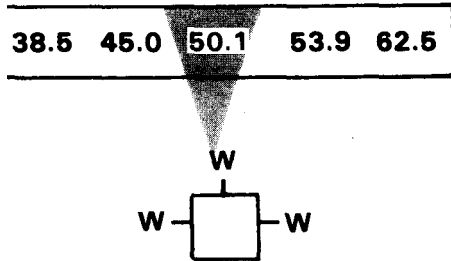

SPOT JAMMING CONCENTRATES MOST OF THE JAMMING POWER ON ONE SELECTED FREQUENCY. IT IS USEFUL FOR ACCURATE, EFFECTIVE, CONTROLLED JAMMING OF A SELECTED FREQUENCY. POWER IS NOT WASTED ON FREQUENCIES OTHER THAN THE SELECTED ONE. IN THIS MANNER, SPOT JAMMING CAN BE USED WITHIN A FREQUENCY BAND WITHOUT INTERFERING WITH OTHER TRANSMISSIONS.

2

BARRAGE JAMMING

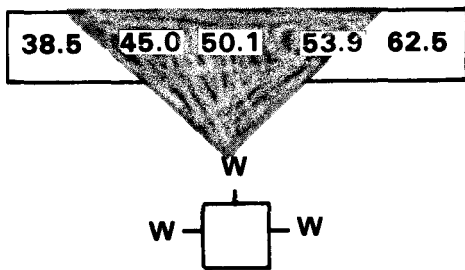

BARRAGE JAMMING SPREADS THE TRANSMITTED POWER OVER A WIDE BAND OF FREQUENCIES. IT AFFECTS ALL FREQUENCIES WITHIN BOTH THE BAND AND THE TRANSMISSION RANGE. SINCE THE TRANSMITTED POWER IS SPREAD OVER A WIDE RANGE OF FREQUENCIES, BARRAGE JAMMING DOES NOT SATURATE ANY SINGLE FREQUENCY. ITS ADVANTAGE IS THAT LITTLE NEED BE KNOWN ABOUT THE RECEIVERS THAT ARE BEING JAMMED. ITS DISADVANTAGES ARE THAT IT WASTES POWER, SINCE IT JAMS FREQUENCIES THAT ARE NOT BEING USED, AND IT INTERFERES WITH ALL TRANSMISSIONS - BOTH ENEMY AND FRIENDLY.

3

SWEEP JAMMING

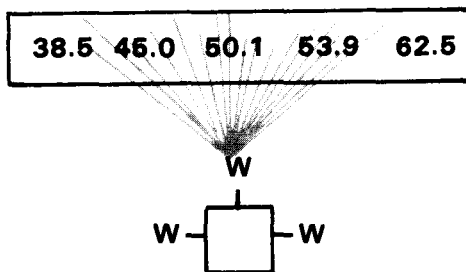

SWEEP JAMMING IS TYPIFIED BY RAPID CHANGES IN THE JAMMING FREQUENCIES THROUGH A WIDE BAND. SWEEP JAMMING IS SIMILAR TO BARRAGE JAMMING IN THAT IT COVERS A WIDE FREQUENCY BAND. IT IS SIMILAR TO SPOT JAMMING IN THAT MOST OF ITS AVAILABLE POWER IS CONCENTRATED ON A SINGLE FREQUENCY, THOUGH ONLY FOR A SHORT TIME, AS THE JAMMER REPEATEDLY SWEEPS BACK AND FORTH ACROSS THE BAND. AS THE SWEEPER MOVES ACROSS THE BAND, EACH FREQUENCY GETS ALMOST ALL THE POWER OF THE JAMMING SIGNAL. ALTHOUGH THE POWER OF THE JAMMER IS ONLY BRIEFLY CONCENTRATED ON A FREQUENCY, IT TAKES TIME FOR THE RECEIVER CIRCUITRY TO RECOVER FROM THE EFFECTS OF THE JAMMING SIGNAL.

OPERATING ON THE EW BATTLEFIELD

You can use five classes of countersuppression measures to increase your survivability and operate on the EW battlefield.

DECEPTION

Deception includes measures which prevent the Threat from spotting a pattern in a unit's actions. Examples of deception techniques are —

Camouflaging Equipment and Personnel. The most important means of avoiding visual detection is through camouflage and concealment of equipment and personnel. FM 5-20 provides a complete reference for all aspects of camouflage. However, the key points to remember are to break up the silhouette or pattern of equipment, and reduce glare.

The pattern of the equipment can be broken up by pattern painting, using natural vegetation, and by using the current series of camouflage nets. These nets will break up both the visual and the IR patterns of the equipment. Keep the camouflage natural looking. In fast moving operations, watch for changing vegetation and change your camouflage accordingly.

Glare can also be reduced by pattern painting and by covering reflective surfaces. Windshields, mirrors, lights, and light-colored surfaces all reflect sunlight to some extent and can be seen by the enemy at far distances.

Displacing Frequently. Movement is the most important means for Stinger teams to defeat AD suppression. Teams should select alternate positions at least 200-300 meters from the primary position and displace to them when necessary. Whenever possible, teams should move at night and during periods of reduced visibility. This will maximize concealment and capitalize on decreased enemy air activity.

Preparing False Positions and Using Decoys. The Threat can be fooled if something can be made to look like a real

item of equipment. Stinger equipment is relatively small, therefore, decoys can be simple. Anything resembling a ¼-ton truck can be used: boxes, framework and netting nailed together so that from a distance the outline of the vehicle is seen. Decoys can be as sophisticated as inflatable ¼-ton trucks, complete with false RF emitters. When using decoys, leave one or two items partially exposed to attract the attention of the Threat. Dummy positions will work only if the real position is well camouflaged.

INFORMATION SECURITY.

Information security measures are taken to prevent disclosure of operational information through written, verbal, or graphic means. The most important information security measures to take are to restrict personnel entry into operational areas and to restrict the release of operational documents and information. These measures will safeguard against unintentional release of data important to the enemy. Other information security techniques to be used are —

- Brief all platoon personnel on SAEDA.
- Brief all personnel about an operation at the latest possible moment.
- Limit "shotgun" message traffic.
- Limit operational information to persons with a need to know.
- Refrain from posting operational information (to include radio frequencies and call signs) on vehicle windshields and other nonsecure areas.
- Clear all signs of vehicular movement into and out of positions. Use existing roads and trails whenever possible; keep new tracks to a minimum.
- Enforce noise and light discipline.
- Destroy all classified material after use or when no longer needed.
- Police all areas thoroughly prior to departure.

PHYSICAL SECURITY

Stinger sections and teams take all available active and passive security measures consistent with the enemy threat. Active measures include establishing listening posts, observation posts, and minefield. Passive measures include the use of cover, concealment, and field fortifications. Deployed teams rely primarily on passive measures. This is because they lack enough personnel to independently implement active measures. Stinger teams should assume positions which are offset from the supported unit to the maximum extent possible. The positions should be consistent with the tactical and technical requirements of the Stinger weapon system. The purpose of this dispersion is to avoid being targeted by association when the defended force comes under direct or indirect fire. In addition, each Stinger section and team uses challenge and password, foxholes, sandbags, and defilade positions.

Remember when constructing fortifications, not to violate the principles of camouflage and concealment. Make your fortifications blend into the terrain by disposing of freshly dug earth and covering them with foliage or netting.

SIGNAL SECURITY

Signal security (SIGSEC) protects operational information through the practice of communications security (COMSEC) and electronic security (ELSEC) techniques. COMSEC techniques include the use of communications codes, secure radio equipment, and proper RATELO procedures. ELSEC techniques include radio and radar emission control (EMCO) measures. Specific COMSEC and ELSEC techniques you can use are —

- Disperse radio antennas rather than concentrating them in a group around a command post (CP). A large antenna grouping indicates a high-value asset.

- Use directional antennas whenever possible.
- Use the lowest possible transmitter power output. This will allow only minimum radiated power to reach the Threat.
- Avoid significant increases or surges of radio traffic on your nets. Traffic volume indicates the relative importance of your unit and mission, or the urgency of the situation. On the other hand, don't completely silence your nets. Radio silence on normally active nets will also indicate an upcoming operation to the Threat.
- Minimize the message length. Preplan your transmissions and keep messages short and to the point.
- Eliminate unnecessary equipment checks and discourage operator chatter. Always assume your equipment is operational, not nonoperational. Don't contact another station for an equipment check just because you haven't heard anything over the net for a long time.
- Move radio operators from section to section on a random basis. Just as you recognize certain voices on the telephone, Threat agents at monitoring stations can identify people by their voice and speech patterns.
- Use couriers, messengers, and wire whenever possible, instead of using radio.
- Change radio transmission sites often. If a transmitter stays several hours at one location, threat targeting is inevitable.
- Operate radios on a random schedule, rather than on a fixed pattern. Random transmission will increase the Threat's collection problems.
- Use terrain features such as hills, vegetation, and buildings to mask your transmissions.

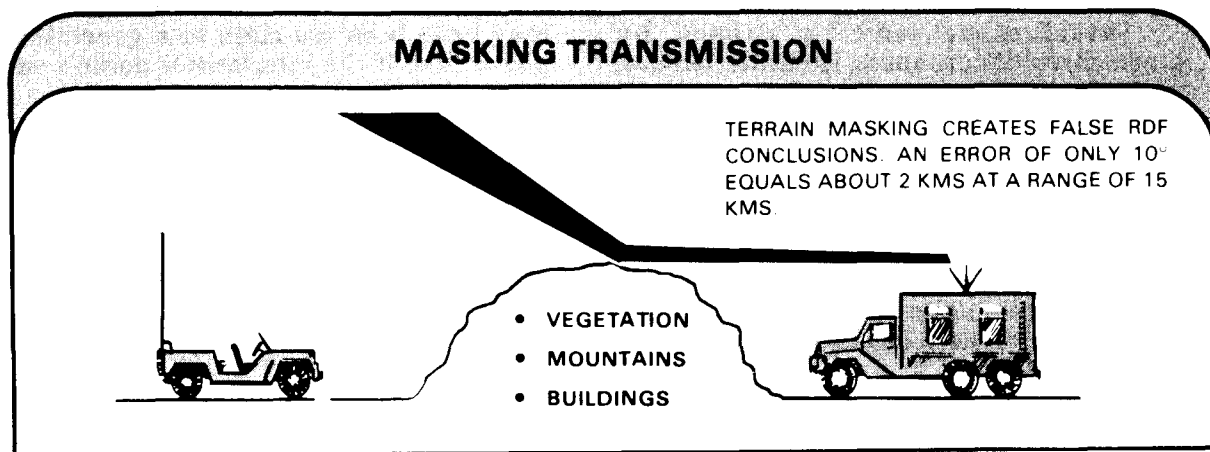

ELECTRONIC COUNTER-COUNTERMEASURES (ECCM)

ECCM are methods used to reduce or eliminate the effects of an enemy's countermeasures, or ECM. How effective these methods are depends on the operator as well as his equipment. Good equipment is useless in the hands of untrained personnel. Remember, "surprise and panic are the greatest threats in the area of electronic warfare." Only through constant training and drill can an operator gain confidence and realize the full capabilities of his equipment.

Radio ECCM are countermeasures for imitative communications deception (ICD) and radio jamming. Message authentication is the best way to prevent imitative communications deception. Radio operators are required to authenticate when —

- They suspect the Threat is on the net.
- Someone challenges them to authenticate.
- Directing a station to go to radio silence or to break that silence. (Self-authentication can be used if authorized.)
- Talking about enemy contact or issuing a follow-up report.

- Transmitting directions which affect the tactical situation, such as: "Move to. . ." or "Turn off your radio." Also, radio operators challenge any directives like these with a request to authenticate.
- Canceling a message.
- Opening the net or when they resume transmitting after a long period of silence.
- Transmitting a classified message in the clear.

If an operator is not sure that authentication is required, he should challenge! If a station takes more than 20 seconds to authenticate, rechallenge! Why 20 seconds? Because a Threat agent will try to contact some other station and have it respond to that same challenge. Once he gets the answer, he'll call back and blame the delay on some equipment failure.

The first thing for Stinger radio operators to do when they experience radio interference is to determine its source. Is the interference unintentional, or is it radio jamming?

Interference may be caused by atmospheric disturbances, local interference, weak signals, or enemy jamming.

Jamming may take many forms and may, therefore, be undiscernible to the untrained operator. All potential radio operators should be trained in threat jamming techniques and to determine if jamming is actually taking place. No counter-countermeasures should be taken until it has first been determined if jamming is taking place.

The operator should use the following steps to determine if his radio is being jammed.

Detach The Radio Antenna. If the interference continues, it means there is a problem with your radio. If the interference stops, it has to be coming from a source outside the radio — either jamming or a problem in the antenna.

Check The Frequencies On Either Side Of The Operating Frequency. Because of the crowded frequency spectrum, the Threat will normally work against selected targets (spot jamming) in order to protect his own communications. If the interference falls off on either side of the operating frequency, then one operator is probably being spot-jammed.

Move The Radio To A New Location. If the interference varies greatly, your radio

may have been too close to a generator or power line. If the interference doesn't vary, you're probably being jammed.

Once the radio interference has been identified as jamming, take the following steps —

- Report the jamming, using a different (and secure, if possible) means of communications. Don't announce over nonsecure means that you are being jammed, because this will tell the Threat how successful he is in jamming you.
- ★ Try to work through the jamming by increasing transmitter power. Move the antenna to a position where it is masked from the Threat and slow down your rate of transmission. Repeat each word and use the phonetic alphabet as necessary. Don't yell into the microphone — this will only create additional side noises.

Build and use a horizontally polarized, directional antenna. This will increase the effective radiated power of your radio. For best results, however, antenna polarization should be the same for all the stations on your net. FM 24-1 shows how to build field expedient antennas.

- Finally, if all your attempts to evade or work through the jamming fail, switch your mode of communications. Wire systems and messengers are always reliable as alternative means of communications.

★ COMMUNICATIONS-ELECTRONICS OPERATION INSTRUCTIONS (CEOI)

DESCRIPTION

The CEOI is a document designed to control communications. Each edition contains the necessary material and information for 1 month. The following list shows the various items which may be found in a CEOI:

- Handling instructions.
- Index.
- Suffixes.
- Radio call signs and frequencies.
- Item number identifiers.
- Sound signals.

- Panel signals.
- Wire tagging system.
- Interference reports.
- Message reference numbers.
- Field telephone instructions.
- Telephone switchboard designators.
- Pyrotechnic and smoke signals.
- Signs and countersigns.
- Transmission security instructions.
- Key list.
- Operations code.
- Authentication instructions.
- Transmission authentication tables.
- Numeral cipher/authentication system.

This appendix will not explain the use of all of these items. Further information can be found in FM 24-1.

PHYSICAL SECURITY AND COMPROMISE

The CEOI is classified if its contents require it. Normally, operational and contingency CEOIs are classified **CONFIDENTIAL**. Administrative or training CEOIs are usually classified to make their handling easier.

Classified CEOIs must be handled with all the precautions associated with any classified document. The CEOI possibly can be compromised. As a precaution, the complete CEOI will not be taken forward of a battalion headquarters. Only a 10-day segment of the CEOI is issued to the user at any one time.

If compromise occurs, it must be reported through the chain of command immediately. A CEOI is considered compromised when any portion of it is lost, captured, or exposed to unauthorized personnel. Another case is when the contents are so misused they

endanger the security of the communications system.

CALL SIGNS

A call sign is a letter-number-letter combination assigned to a unit. Every unit in an organization has a different call sign.

The complete call sign is used under the following conditions:

- When opening a net.
- When entering a net in which you do not normally operate.
- When responding to a net call.
- When requested by NCS or any other station.
- When radio reception is poor.

At other times the last letter of the call sign with the suffix can be used. The last letter will be different for all stations in a net.

CALL SIGNS				
(PROTECTIVE MARKING)				
KTV 600 A 14TH INF DIV (M)	CALL SIGNS			3
	01	02	03	04
DIV	U7C	F9L	U4X	B9Y
HHC	C2U	M6Q	L4I	D1P
RETRANS ST4	X6M	L4B	T9V	A5N
DIV TOC	C5J	S8J	M6M	E6C
DIV PSE	R9N	L6N	O2R	Q4A
2 BDE	E3Q	H7B	E5W	R5S
CEUI	M8F	B3D	G8C	X7T

SUFFIXES

Call sign suffixes are two-number groups assigned to positions or activities within a unit. In a training CEOI, these are usually fixed. In an operational CEOI, they are randomly assigned on a daily basis. An expander letter can be attached to the basic suffix for further identification of positions or activities if required. The call sign and suffix together identify the sender and receiver of a radio message.

SUFFIXES		
(PROTECTIVE MARKING)		
KTV 600 Series	SUFFIXES	2
01	G1/S1	
02	G2/S2	
03	G3/S3	
04	G4/S4	
05	G5/S5	
06	CHIEF OF STAFF / EXECUTIVE OFFICER	
07	COMMANDER / PLT LDR / SEC LDR / OIC	
08	CSM / SGM	
09	MAINTENANCE OFFICER	
10	INSPECTOR GENERAL	
11	SIGNAL OFFICER / C-E OFFICER	
12	ADC-1 / DEPUTY COMMANDER / ADC O	
13	ADC-2 / ADC S	
14	G3/S3 OPS	
15	AVIATION OFFICER	
16	ENGINEER OFFICER	
17	SURGEON / MEDICAL OFFICER	
18	FIRST SERGEANT	
19	SAFETY OFFICER	
20	CHAPLAIN	
21	ADSO	
22	G2/S3 AIR	
23	G3/S3 AIR	
24	CHEMICAL OFFICER	
25	AIR DEFENSE OFF	
26	RETRANS STA / RWI STA OPR	
27	PLATOON / SECTION SGT	
28	NET CONTROL STATION	
29	AMMUNITION OFFICER	
30	PROVOST MARSHAL	
SUFFIXES	1 of 4	2

FREQUENCY ASSIGNMENTS

Each radio net is assigned a primary frequency and an alternate frequency. These frequencies change daily unless other instructions are given by the CEOI controlling authority. The daily change time is in the CEOI special instructions.

FREQUENCY ASSIGNMENTS				
(PROTECTIVE MARKING)				
KTV 600 A	FREQUENCIES			3
14TH INF DIV (M)	Ø1	Ø2	Ø3	Ø4
DIV CMD	33 05	36 20	42 20	43 25
RETRANS	64 90	59 09	69 70	61 00
DIV OPS	34 25	32 95	32 65	43 55
RETRANS	63 45	67 40	24 60	62 35
DIV INTEL	41 60	39 20	46 20	42 05
RETRANS	67 25	62 05	27 60	62 35
DIV FSE	88 95	42 20	67 60	23 60
HHC CMD	44 45	37 30	30 75	47 36
DIV RWI STA	36 05	45 00	35 50	27 95
MEDEVAC P	43 68	46 35	62 25	45 50

OPERATIONS CODE, AUTHENTICATION INSTRUCTIONS, AND TRANSMISSION AUTHENTICATION ASSIGNMENTS

These items explain the use of operations codes, the circumstances under which authentication is mandatory, and the use of transmission authentication tables. Columns in the transmission authentication table are also assigned to specific units. The numeral cipher/authentication system is explained as a separate item. Proper use of these items is critical to communications security.

REMEMBER

THIS APPENDIX ONLY GIVES A BRIEF ORIENTATION TO THE CEOI TO BE PROFICIENT. STINGER PERSONNEL MUST STUDY AND PRACTICE USING THE CEOI AT EVERY OPPORTUNITY.

★ APPENDIX C

Emergency Warning Signals

Air attacks will be swift and often unexpected. Therefore, early warning of a probable attack is necessary to give troops a chance to take cover. This warning may be passed through normal command channels, or given by local observation posts, Stinger teams, or air sentries. All observation posts should have air watch included in their duties and alertness for enemy aircraft required as part of normal observation. They will not always have a good view of the air around them, in which case a special air guard must be detailed. All vehicles should have an air guarded detailed.



Hostile, low-flying aircraft may appear suddenly from behind low hills, belts of trees, or haze. To gain surprise, they will try to attack you with the sun behind them.

The alarm must be given immediately, if troops working in the open are to have any chance of taking cover. This warning is the responsibility of every man in the area and will be passed by whistle, voice, radio, or any other method. When the alarm is given, all troops except those in close contact with the enemy must immediately take cover, if possible, below ground level, and remain there until the all-clear is given.

Evasive maneuver is the initial reaction of mounted units under air attack. Each vehicle turns away from an airplane's axis of attack and seeks cover and concealment. They then shoot at attacking aircraft as appropriate.

STINGER PERSONNEL MUST UNDERSTAND ALL WARNING SIGNALS AS PRESCRIBED IN UNIT STOP

To provide a standard method of disseminating emergency warnings within NATO forces operating on land, the United States Armed Forces have concurred in the provisions of STANAG 2047 Emergency Alarms of Hazard or Attack, in NBC and air attack only. Pertinent extracts from STANAG 2047 suitable for use by Stinger personnel are listed in the Emergency Alarms and Warning Signal illustration.

EMERGENCY ALARMS AND WARNING SIGNALS		
TYPES OF HAZARDS	VISUAL WARNING SIGN	AUDIBLE ALARM SIGNAL
IMMINENT AIR ATTACK.	RED. PREFERABLY SQUARE IN SHAPE.	UNBROKEN WARBLING SIREN FOR 1 MINUTE. SUCCESSION OF LONG BLASTS ON VEHICLE HORNS, WHISTLES, BUGLES, OR OTHER WIND INSTRUMENTS IN A RATIO OF 3:1; APPROXIMATELY 3 SECONDS ON AND 1 SECOND OFF. VOCAL "AIR ATTACK", OR CORRESPONDING NATIONAL TERM WHERE ONLY ONE NATION IS INVOLVED.
IMMINENT ARRIVAL OF, OR PRESENCE OF CHEMICAL OR BIOLOGICAL AGENTS, OR RADIOLOGICAL HAZARDS.	BLACK. PREFERABLY TRIANGULAR IN SHAPE.	INTERRUPTED WARBLING SOUND ON A SIREN.

EMERGENCY ALARMS AND WARNING SIGNALS—CONTINUED		
TYPES OF HAZARDS	VISUAL WARNING SIGN	AUDIBLE ALARM SIGNAL
ALL CLEAR.	<p>DONNING MASKS AND TAKING PROTECTIVE ACTION FOLLOWED BY SUCH HAND SIGNALS AS MAY BE PRESCRIBED IN LOCAL SOP. (SEE NOTES 1, 2, and 3).</p> <p>REMOVAL OF APPROPRIATE WARNING SIGN.</p>	<p>SUCCESSION OF SHORT SIGNALS ON VEHICLE OR OTHER HORNS, OR BY BEATING METAL OBJECTS IN A RATIO OF 1:1; APPROXIMATELY 1 SECOND ON AND 1 SECOND OFF</p> <p>VOCAL "GAS, GAS, GAS;" OR CORRESPONDING NATIONAL TERM WHERE ONLY ONE NATION IS INVOLVED.</p> <p>VOCAL "FALLOUT, FALLOUT, FALLOUT;" OR CORRESPONDING NATIONAL TERM WHERE ONLY ONE NATION IS INVOLVED.</p> <p>VOCAL "ALL CLEAR (SPECIFY TYPE OF ATTACK);" OR CORRESPONDING NATIONAL TERM WHEN ONLY ONE NATION IS INVOLVED.</p> <p>STEADY SIREN NOTE FOR ONE MINUTE, OR SUSTAINED BLAST ON A VEHICLE HORN, WHISTLE, BUGLE, OR OTHER WIND INSTRUMENT TO INDICATE ABSENCE OF ALL NBC AND AIR ATTACK HAZARDS.</p>
<p>Notes:</p> <ol style="list-style-type: none"> Automatic alarms for the early and rapid detection of biological and chemical agents or radiological hazards may complement the devices referred to previously. A special audio-visual pyrotechnic signal producing a whistle sound, and a yellow, red, yellow display of lights may be used. The combination of colors should be produced as near simultaneously as possible. Wearing masks in the presence of radiological hazards is not mandatory, but will be decided by the local commander. 		

★ APPENDIX D

Small Arms in the Air Defense Role

Many of a unit's non-air-defense weapons (small arms and machine guns) are normally used against the enemy's ground forces. When the unit comes under air attack, these should be temporarily diverted to destroy or drive off attacking aircraft. Fires from air defense artillery weapons, small arms, and machine guns must be massed against the air threat. Stinger personnel are air defense artillerymen. As such, they advise and assist supported unit personnel in learning when and how to fire at enemy aircraft.

All units must be able to use small arms and machine guns to counter enemy air attacks.

WHEN TO FIRE

The decision to engage aircraft with small arms and machine guns is normally made by the unit commander. The rule for his decision is simple — *if aircraft attack the unit, return fire.*

If the aircraft is not attacking the unit, the unit commander makes the decision of whether to engage or not to engage the aircraft. The commander may not want to engage the aircraft and disclose his unit's position. If he decides to engage, he must be able to positively identify the aircraft as

hostile. The unit commander must remember that if his unit is not being attacked, he must give the order to fire.

CONTENTS	
	PAGE
When to Fire	D-1
How to Fire	D-2
Interaction with Stinger	D-3

HOW TO FIRE

Start by looking at how one man should fire at one aircraft. If the aircraft is attacking, he will probably see a head-on view or crossing view of the target as shown below.

SOLDIER'S VIEW OF THE TARGET

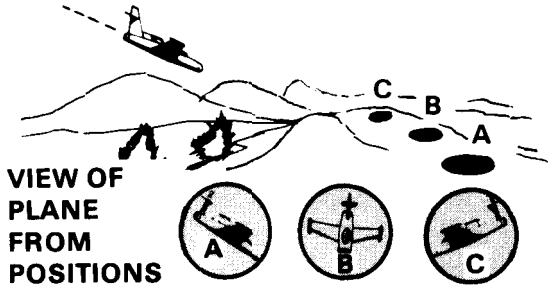

AN INDIVIDUAL SOLDIER FIRING A RIFLE OR A MACHINE GUN CAN ACHIEVE HITS ON AN ENEMY AIRCRAFT WHEN HE LEADS THE TARGET. DEPENDING ON HIS POSITION, THE SOLDIER WILL VIEW THE TARGET AS EITHER HEAD-ON (POSITION B) OR CROSSING (POSITIONS A AND C).

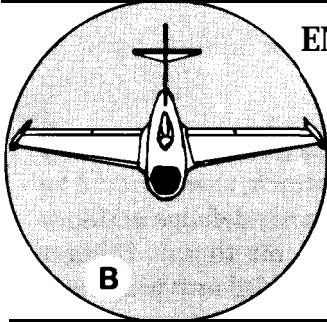

ENGAGING AN AIRCRAFT HEAD-ON

THE SOLDIER SHOULD AIM SLIGHTLY ABOVE THE AIRCRAFT'S NOSE AND FIRE. THE OBJECTIVE IS TO PUT AS MANY ROUNDS AS POSSIBLE INTO THE AIR FOR THE AIRCRAFT TO FLY INTO.

ENGAGING A CROSSING AIRCRAFT

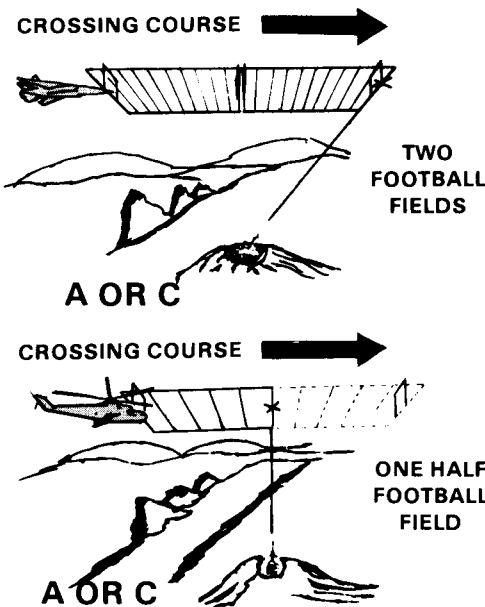

THE SOLDIER ENGAGES CROSSING AIRCRAFT BY JUDGING THE DIRECTION OF FLIGHT OF THE TARGET AND LEADING IT. THE CORRECT AIMING POINT CAN BE DETERMINED IN TERMS OF A NUMBER OF FOOTBALL FIELDS. FOR JET AIRCRAFT THE SOLDIER AIMS AT LEAST TWO FOOTBALL FIELDS IN FRONT OF THE TARGET. FOR HELICOPTERS AND PROPELLER-DRIVEN AIRCRAFT THE LEAD DISTANCE IS ONE-HALF FOOTBALL FIELD. IF A HELICOPTER IS HOVERING, THE SOLDIER WOULD, OF COURSE, AIM DIRECTLY AT THE TARGET. EACH INDIVIDUAL WILL PERCEIVE THIS LEAD DIFFERENTLY. THEREFORE, A WINDOW, MUCH LIKE A SHOTGUN PATTERN, WILL BE ESTABLISHED WHICH THE TARGET MUST FLY THROUGH.

THE FIRER SHOULD NOT ATTEMPT TO TRACK THE TARGET; THAT IS, TO MAINTAIN THE SAME LEAD ON THE TARGET THROUGHOUT FIRING. THE FIRER SHOULD ESTABLISH HIS AIMING POINT AND FIRE ALL OF HIS ROUNDS AT THAT POINT. RIFLEMEN SHOULD FIRE AN ENTIRE MAGAZINE AT THE AIMING POINT. MACHINE GUNNERS SHOULD FIRE AT LEAST A 50-ROUND BURST.

The best small arms protection against attacking aircraft is volume fire. It is effective. With everyone shooting at once, a large volume of airspace will be covered. All soldiers will use their projected lead

(visualizing football fields). However, some will fire with too much lead and some with too little. But with everybody shooting, enough rounds will go to the right place in front of the aircraft.

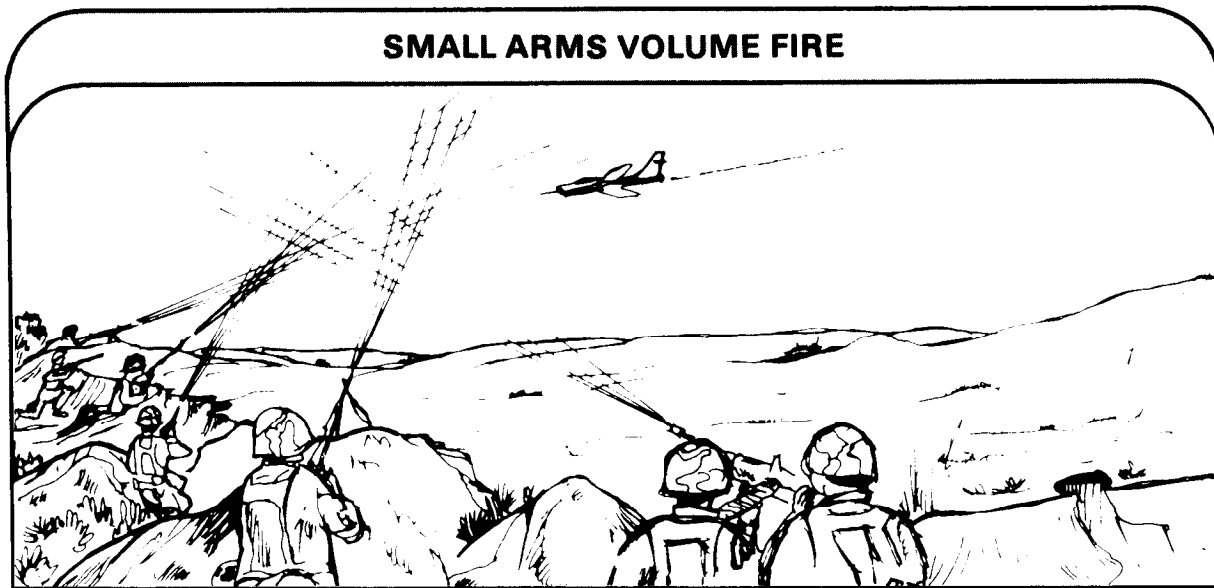

INTERACTION WITH STINGER

In combat, the Stinger team will receive an alert warning of unknown aircraft approaching the unit's position. The warning alerts the unit of a possible air attack. This is done by using the unit's command net and/or signals prescribed by the unit SOP. The unit personnel with equipment can take appropriate action. They seek cover and concealment, disperse, and/or take other measures as the situation requires. They then prepare to return fire, if attacked by enemy aircraft.

Together, Stinger, small arms, and machine guns can destroy, drive away, or reduce the effectiveness of attacking aircraft. They put a volume of fire from the unit's organic weapons and Stinger missiles in the air. Even if the aircraft is not destroyed, the pilot's ordnance delivery probably will be inaccurate. It is even more probable that he won't return for a second attack on the unit.

Reference FM 44-8 for information on use of small arms against air attack.

REMEMBER

THE COMMANDER CAN MAKE JUDICIOUS USE OF AVAILABLE AIR DEFENSE RESOURCES AND SMALL ARMS AND MACHINE GUNS IN THE AIR OFFENSE ROLE. HE MAY ACHIEVE SUCCESS ON A BATTLEFIELD WHICH OTHERWISE MIGHT BE DOMINATED BY SUPERIOR AIR FORCES. HE MAY NOT COMPLETELY DESTROY THE THREAT. HOWEVER, HE CAN, IN FACT, DEFEAT IT OR REDUCE ITS EFFECTIVENESS. PERSONNEL CAN FIRE TRACERS AND MISSILES WHICH THE PILOT CAN SEE. FREQUENTLY, THESE CONVINCE HIM TO INITIATE ESCAPE MANEUVERS OR CAUSE A REDUCED ACCURACY OF ORDNANCE DELIVERY.

APPENDIX E

Small Arms in the Air Defense Role

Many of a unit's non-air-defense weapons (small arms and machine guns) are normally used against the enemy's ground forces. When the unit comes under air attack, these should be temporarily diverted to destroy or drive off attacking aircraft. Fires from air defense artillery weapons, small arms, and machine guns must be massed against the air threat. Stinger personnel are air defense artillerymen. As such, they advise and assist supported unit personnel in learning when and how to fire at enemy aircraft.

All units must be able to use small arms and machine guns to counter enemy air attacks.

WHEN TO FIRE

The decision to engage aircraft with small arms and machine guns is normally made by the unit commander. The rule for his decision is simple — *if aircraft attack the unit, return fire.*

If the aircraft is not attacking the unit, the unit commander makes the decision of

whether to engage or not to engage the aircraft. The commander may not want to engage the aircraft and disclose his unit's position. If he decides to engage, he must be able to positively identify the aircraft as hostile. The unit commander must remember that if his unit is not being attacked, he must give the order to fire.

CONTENTS	
	PAGE
When to Fire	E-1
How to Fire	E-2
Interaction with Stinger	E-3

HOW TO FIRE

Start by looking at how one man should fire at one aircraft. If the aircraft is attacking, he will probably see a head-on view or crossing view of the target as shown below.

SOLDIER'S VIEW OF THE TARGET

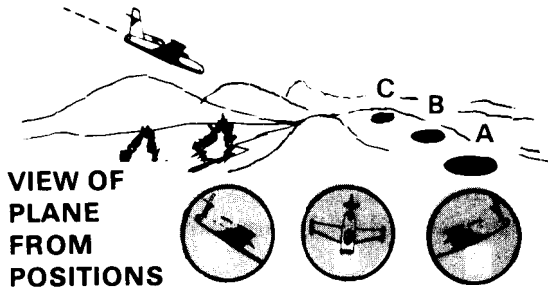

AN INDIVIDUAL SOLDIER FIRING A RIFLE OR A MACHINE GUN CAN ACHIEVE HITS ON AN ENEMY AIRCRAFT WHEN HE LEADS THE TARGET. DEPENDING ON HIS POSITION, THE SOLDIER WILL VIEW THE TARGET AS EITHER HEAD-ON (POSITION B) OR CROSSING (POSITIONS A AND C).

ENGAGING AN AIRCRAFT HEAD-ON

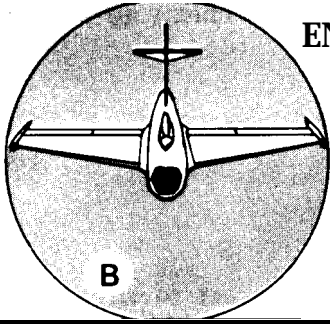

THE SOLDIER SHOULD AIM SLIGHTLY ABOVE THE AIRCRAFT'S NOSE AND FIRE. THE OBJECTIVE IS TO PUT AS MANY ROUNDS AS POSSIBLE INTO THE AIR FOR THE AIRCRAFT TO FLY INTO.

ENGAGING A CROSSING AIRCRAFT

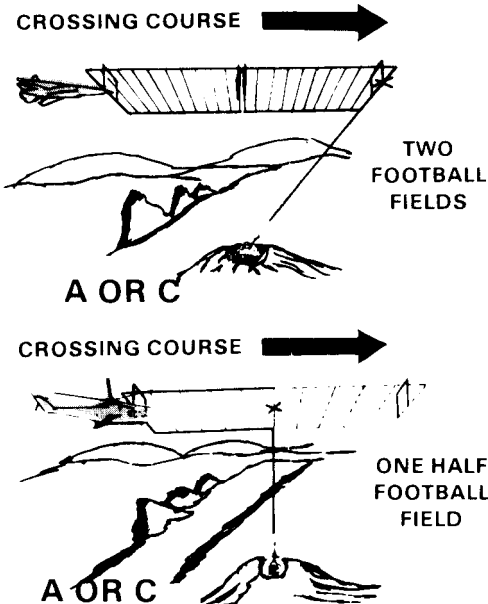

THE SOLDIER ENGAGES CROSSING AIRCRAFT BY JUDGING THE DIRECTION OF FLIGHT OF THE TARGET AND LEADING IT. THE CORRECT AIMING POINT CAN BE DETERMINED IN TERMS OF A NUMBER OF FOOTBALL FIELDS. FOR JET AIRCRAFT THE SOLDIER AIMS AT LEAST TWO FOOTBALL FIELDS IN FRONT OF THE TARGET. FOR HELICOPTERS AND PROPELLER-DRIVEN AIRCRAFT THE LEAD DISTANCE IS ONE-HALF FOOTBALL FIELD. IF A HELICOPTER IS HOVERING, THE SOLDIER, WOULD, OF COURSE, AIM DIRECTLY AT THE TARGET. EACH INDIVIDUAL WILL PERCEIVE THIS LEAD DIFFERENTLY. THEREFORE, A WINDOW, MUCH LIKE A SHOTGUN PATTERN, WILL BE ESTABLISHED WHICH THE TARGET MUST FLY THROUGH.

THE FIRER SHOULD NOT ATTEMPT TO TRACK THE TARGET; THAT IS, TO MAINTAIN THE SAME LEAD ON THE TARGET THROUGHOUT FIRING. THE FIRER SHOULD ESTABLISH HIS AIMING POINT AND FIRE ALL OF HIS ROUNDS AT THAT POINT. RIFLEMEN SHOULD FIRE AN ENTIRE MAGAZINE AT THE AIMING POINT. MACHINE GUNNERS SHOULD FIRE AT LEAST A 50-ROUND BURST.

The best small arms protection against attacking aircraft is volume fire. It is effective. With everyone shooting at once, a large volume of airspace will be covered. All soldiers will use their projected lead

(visualizing football fields). However, some will fire with too much lead and some with too little. But with everybody shooting, enough rounds will go to the right place in front of the aircraft.

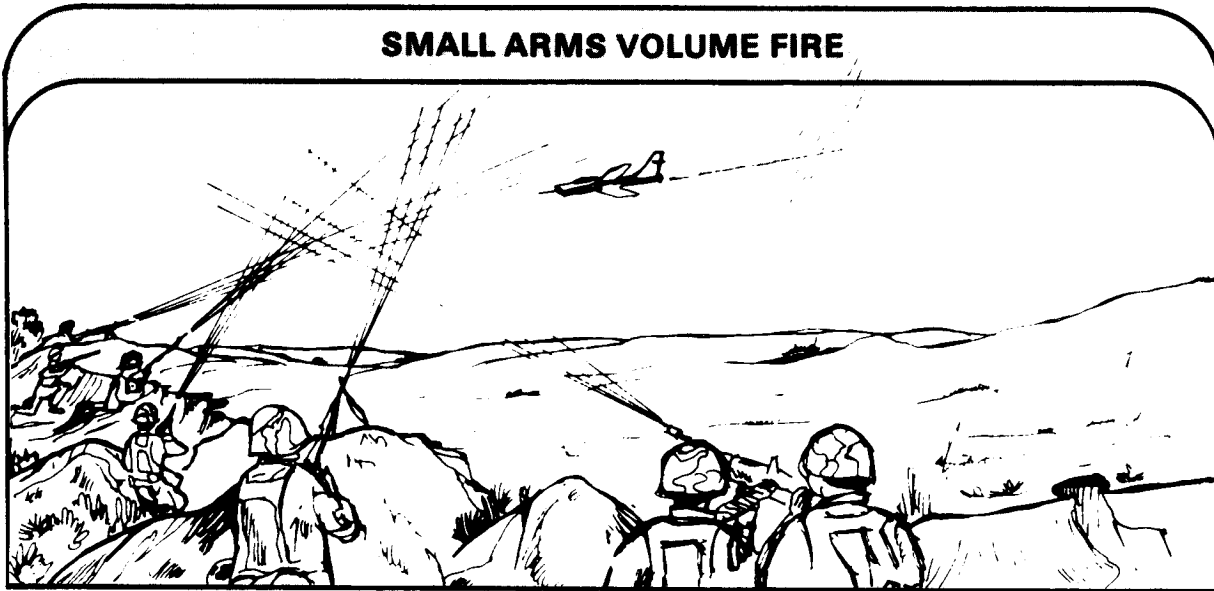

INTERACTION WITH STINGER

In combat, the Stinger team will receive an alert warning of unknown aircraft approaching the unit's position. The warning alerts the unit of a possible air attack. This is done by using the unit's command net and/or signals prescribed by the unit SOP. The unit personnel with equipment can take appropriate action. They seek cover and concealment, disperse, and/or take other measures as the situation requires. They then prepare to return fire, if attacked by enemy aircraft.

Together, Stinger, small arms, and machine guns can destroy, drive away, or reduce the effectiveness of attacking aircraft. They put a volume of fire from the unit's organic weapons and Stinger missiles in the air. Even if the aircraft is not destroyed, the pilot's ordnance delivery probably will be inaccurate. It is even more probable that he won't return for a second attack on the unit.

Reference FM 44-8 for information on use of small arms against air attack.

REMEMBER

THE COMMANDER CAN MAKE JUDICIOUS USE OF AVAILABLE AIR DEFENSE RESOURCES AND SMALL ARMS AND MACHINE GUNS IN THE AIR DEFENSE ROLE. HE MAY ACHIEVE SUCCESS ON A BATTLEFIELD WHICH OTHERWISE MIGHT BE DOMINATED BY SUPERIOR AIR FORCES. HE MAY NOT COMPLETELY DESTROY THE THREAT. HOWEVER, HE CAN, IN FACT, DEFEAT IT OR REDUCE ITS EFFECTIVENESS. PERSONNEL CAN FIRE TRACERS AND MISSILES WHICH THE PILOT CAN SEE. FREQUENTLY, THESE CONVINCE HIM TO INITIATE ESCAPE MANEUVERS OR CAUSE A REDUCED ACCURACY OF ORDNANCE DELIVERY.

Glossary

AATF	Air assault task force	CSS	Combat service support
ACA	Airspace control authority	CW	Chemical weapons/warfare
ADADO	Assistant division air defense officer	DAME	Division airspace management element
ADC	Air defense command	DIVAD	Division air defense
ADCO	Air defense coordination officer	DS	Direct support
ADCS	Air defense coordination section	DX	Direct exchange
ADIZ	Air defense identification zone	ECCM	Electronic counter-countermeasure
ADOA	Air defense operations area	ECM	Electronic countermeasure
ADW	Air defense warnings	ELINT	Electronic intelligence
AH	Attack helicopter	ELSEC	Electronic security
AIM	Armored, infantry, mechanized (infantry divisions)	EMCON	Emission control
AM	Amplitude modulated	EMP	Electromagnetic pulse
ASM	Air-to-surface missile	EW	Electronic warfare
ASP	Ammunition supply point	EWBN	Early warning broadcast net
ATCH	Attachment	FAAR	Forward area alerting radar
ATGM	Antitank guided missile	FAC	Forward air controller
BCC	Battery control central	FACP	Forward air control post
BCO	Battery control officer	FEBA	Forward edge of the battle area
BCU	Battery/coolant unit	FEZ	Fighter engagement zone
CAS	Close air support	FLOT	Forward line of own troops
CBU	Cluster bomb unit	FM	Frequency modulation
C-E	Communications-Electronics	FRAGO	Fragmentary order
CEOI	Communications-Electronics Operating Instructions	GS	General support
CFA	Covering force area	GS-R	General support-reinforcing
COMSEC	Communications security	HIDACZ	High-density airspace control zone.
CP	Command post	HIMEZ	High-altitude missile engagement zone
CRC	Control and reporting center	HUMINT	Human intelligence
CRP	Control and reporting post	IAW	In accordance with
		ICD	Imitative communications deception

ID	Identification	PPI	Plan position indicator
ir	Infrared	PSF	Primary sector of fire
IRCM	Infrared countermeasures	PTL	Primary target line
km	Kilometer	PZ	Pickup zone
KT	Kiloton	R	Reinforcing
★ LADS	Light Air Defense System	Rad	Radiation dose levels
LLTR	Low-level transit route	RATELO	Radiotelephone operator
LOMEZ	Low-altitude missile engagement zone	RDF	Radio direction finding
LZ	Landing zone	RF	Radio frequency
MANPAD	Manportable air defense (system)	RFDL	Radio frequency data link
MBA	Main battle area	ROE	Rules of engagement
MOPP	Mission oriented protective posture	RP	Release point
mph	Miles per hour	RSOP	Reconnaissance, selection, and occupation of position
MRR	Minimum risk route	SAM	Surface-to-air missile
MSCS	Manual SHORAD control system	SAR	Search and rescue
MSU	Missile support unit	SHORAD	Short-range air defense
MT	Megaton	SHORADEZ	Short-range air defense engagement zone
NATO	North Atlantic Treaty Organization	SIGINT	Signal intelligence
NBC	Nuclear, biological, chemical	SITREP	Situation report
NCS	Net control station	SMP	Sensor management plan
OPCOM	Operational command	TADDS	Target alert data display set
OPCON	Operational control	TCO	Tactical control officer
OPORD	Operations order	TF	Task force
OPSEC	Operations security	TOC	Tactical operations center
★ ORL	Ordnance release line	TOE	Table(s) of organization and equipment
PCP	Platoon command post	TOW	Tube (launched), optically (tracked), wire (guided) (antitank missile)
PHOTINT	Photographic intelligence	TSOP	Tactical standing operating procedure
PLL	Prescribed load list	WCS	Weapons control status
POL	Petroleum, oil, and lubrication	WEZ	Weapons engagement zone

★Index

	Page
Accessibility for Team Vehicle	5-9
Air Assault	9-8
Air Assault Division	3-6
Air Defense Area	3-16
Air Defense Artillery Employment Guidelines	5-6
Balanced Fires	5-6
Defense in Depth	5-7
Early Engagement	5-7
Mutual Support	5-6
Overlapping Fires	5-6
Weighted Coverage	5-6
Air Defense Employment Principles	5-1,5-5
Integration	5-5
Mass	5-5
Mix	5-5
Mobility	5-5
Air Defense Identification Zone (ADIZ)	3-16
Air Defense Operations Area	3-16
Air Defense Priorities	5-7
Criticality	5-8
Enemy Air Threat	5-8
Recuperability	5-8
Vulnerability	5-8
Airborne	9-7
Airborne and Air Assault Operations	9-7
Airborne Division	3-5
Allocation of Forces	5-1
Allocation of Stinger Teams	3-3
Alternate (Backup) Communications	4-9
Ammunition (Supply)	10-3
Area Air Defense Commander	3-10
Area Defense	5-5
Armored, Infantry, Mechanized Infantry (AIM) Division	3-2
Armored Cavalry Regiment	3-7
Attachment, US and NATO	3-9

	Page
Attacking Friendly Elements	3-12
Attacks - Hasty and Deliberate	7-3
Attack Techniques	1-8,1-13
Aircraft Speed	1-14
Darkness and Inclement Weather	1-14
Fixed Wing Aircraft	1-8
Limitations of Attack Aircraft	1-14
Low-Altitude Approaches	1-14
Attack Helicopters (AH)	1-13
Antitank Guided Missiles	1-13
Balanced Fires	5-6
Battery/Coolant Unit (BCU)	2-3,10-2
Bearing the Military Markings of a Known Enemy Nation	3-12
Belt Defense	5-5
Boundaries, Launch and Intercept	2-6
Call Signs	B-11
CEOI	4-10,B-10
Characteristics of Threat Ordnance	1-8
Cluster Bomb Units (Ordnance)	1-7
Combat Operations	7-1
Combat Operations, How Stinger Supports	7-1
Command	3-7
Command Signal	6-4
Command and Control	3-7
Command and Control of the Stinger Platoon	3-11
Command and Control Procedures	3-12
Command for Divisional Stinger	3-8
Command for Nondivisional Stinger	3-9
Command Relationships	6-1,6-12
Command Statuses, Special	3-9
Common Equipment	10-3
Communications	4-1
Backup	4-9
Radio	4-1,4-4

	Page
Sound	4-10
Visual	4-10
Wire	4-8
Communications-Electronics Operation Instructions (CEOI)	4-10,B-10
Call Signs	B-11
Description	B-10
Frequency Assignments	B-12
Operations Code and Authentication Instructions	B-12
Physical Security and Compromise	B-11
Suffixes	B-12
COMSEC	10-3
COMSEC Items	2-4
Control of Stinger	3-10
Covering Force Area	7-4
Deception	B-7
Defense of Maneuver Units	5-15
Mobility	5-15
Physical Security	5-15
Position Requirements	5-15
Defensive Operations	7-6
Main Battle Area	7-5
Stinger Support in the Defense	7-4
Desert Operations	9-3
Detection, Target	2-7
Direct Support	5-3,5-4
Dismounted Operations	7-5
Defensive Operations	7-6
Offensive Operations	7-6
Emergency Warning Signals	C-1
Employment Guidelines	5-1,5-6
Balance Fires	5-6
Defense in Depth	5-7
Early Engagement	5-7
Mutual Support	5-6
Overlapping Fires	5-6,5-14
Weighted Coverage	5-6
Engaging a Crossing Aircraft	D-2
Engaging an Aircraft Head-on	D-2

	Page
Engagement Command	2-8
Engagement Process	2-7
FAAR	4-7
FAAR/TADDS	4-7
Field Telephones	4-9
Fighter Engagement Zone (FEZ)	3-16
Fire Control Orders	3-14
Cease Engagement	3-14
Engage	3-14
Hold Fire	3-14
Frequency Assignments	B-12
Frostbite	9-2
General Support (GS)	5-3,5-4
General Support - Reinforcing (GSR)	5-3,5-4
Greyout	9-6
Heliborne Assault	1-15
High-Altitude Missile Engagement Zone (HIMEZ)	3-16
High-Density Airspace Control Zone (HIDACZ)	3-17
Hostile Criteria	3-12
Attacking Friendly Elements	3-12
Bearing Military Markings of a Known Enemy Nation	3-12
Operating at Prohibited Speeds, Altitudes, or in Prohibited Directions	3-12
Performing Acts over Friendly Troops without Prior Coordination	3-12
Responding Improperly to IFF Interrogation	3-13
Unauthorized or Improper Entry into an Area	3-12
How Stinger Supports Combat Operations	7-1
How to Fire	D-2
Identification, Target	2-7
IFF (Identification, Friend or Foe)	2-3
Code Interrogator Computer	2-5
Code Keys	2-5
IFF Replies and Weapons Control Statuses	3-13
IFF Systems	10-2
IFF Sequence	3-12
Interrogate Aircraft	2-7
Interrogator	2-3
Programmer/Battery Charger	2-3

	Page
Information Security	B-7
Integration	5-5
Interaction with Stinger	B-7
IR Acquisition/Uncaging	2-8
Jamming Techniques	B-6
Jet/Prop Determination	2-7
Jungle Operations	9-3
Loss of Communications	3-15
Weapons Free	3-15
Weapons Hold	3-15
Weapons Tight	3-15
Low-Altitude Missile Engagement Zone (LOMEZ).....	3-16
Medical Support	10-3
Military Operations in Urban Terrain	9-10
Minimum Risk Route/Low-Level Transit Route (LLTR)	3-18
Missile Round	2-1
Missile-Round Container	2-5
Mountain Operations	9-1
Night Operations	9-10
Northern Operations	9-5
Offensive Operations	7-2
Attacks - Hasty and Deliberate	7-3
Movements to Contact	7-2
Planning for the Attack	7-4
Stinger Support in the Offense	7-2
Types of Offensive Operations	7-2
Operational Command (OPCOM)	3-9
Operational Control (OPCON)	3-9
Operational Code and Authentication Instructions	B-12
Operating on the EW Battlefield	B-7
Operations Security (OPSEC)	B-1
Ordnance Delivery Techniques	1-9
Lay-down	1-9
Pop-up	1-9
Standoff	1-12

	Page
Laser - Guided Bombs	1-12
Smart Bombs and Guided Missiles	1-12
TV - Command System	1-12
Organization of Stinger	3-1
Allocation of Stinger Teams and Sections within Major Organizations	3-2
Army of Excellence Organizations	3-3
Divisional	3-2
Armored, Infantry, Mechanized (AIM) Infantry	3-2
<i>Heavy</i>	3-4
<i>Light</i>	3-4
<i>Motorized Infantry</i>	3-5
Nondivisional	3-6
Armored Cavalry Regiment	3-7
Separate Brigade	3-6
Platoon	3-2
Section	3-1
Team	3-1
Organizing for Combat	5-2
Other Common Equipment	10-3
Other Logistical Support	10-3
Physical Security	B-8
Physical Security and Compromise	B-11
Platoon Command Net	4-4
Platoon Headquarters	
Internal Operations	6-8
Intelligence	6-11
Terrain and Weather	6-12
Threat Air Intelligence	6-11
Operational Aids	6-8
Air Defense Status Chart	6-14
Journal of Events	6-11
Operations Overlay	6-13
Personnel	
Platoon Sergeant	6-8
Radiotelephone Operator (RATELO)/Driver	6-8
Point Defense	5-10
Moving	5-13
Convoys	5-13
Integrating Teams into the March Column	5-13
Overlapping Fires	5-16
Pre-positioning Teams Along the Route of March	5-13
Stationary	5-10

	Page
Map Analysis	5-12
Routes of Approach	5-10
Threat Characteristics and Ordnance Release Line	5-11
Vital Points within a Critical Asset Defense	5-10
Position Requirements for Stinger	5-15
Accessibility for Team Vehicles	5-9
Communications	5-8
Cover and Concealment	5-9
Observation and Fields of Fire	5-8
Physical Security	5-9,5-15
Technical	5-8,5-9
Potential Threat Determination	2-7
Primary Sector of Fire (PSF)	3-20
Primary Target Line (PTL)	3-20
Programmer/Battery Charger	2-3
Radio Characteristics	4-3
Radio Electronic Countermeasures	B-3
Radio Nets	
Platoon Command Net	4-4
Section Command Net	4-4
Stinger Netting with Vulcan Platoon	4-7
Stinger Platoon Net in AIM Division	4-4
Team Netting in AIM Division	4-6
Team Netting in Air Assault Division	4-6
Team Netting in Airborne Division	4-6
Radio SIGSEC Techniques	B-8
Reconnaissance, Selection, and Occupation of Position (RSOP)	6-5
In Response to a Change in Mission	6-7
Platoon Operations	6-7
RSOP Sequence	6-6
When a Defended Asset or Unit Moves	6-6
Region Air Defense Commander	3-10
Restricted Operations Areas	3-17
Restricted Operations Area for Aircraft	3-18
Restricted Operations Area for ADA	3-18
Right of Self-Defense	3-14
River Crossing Operations	9-11,9-12
Section Headquarters Element	3-11

	Page
Command Relationships	6-12
IFF Reprogramming	6-14
Internal Operations	6-12
Operational Aids	6-13
Section Chief Duties	6-12,6-13
Self Defense	3-14
Separable Gripstock Assembly	2-2
Shipping and Storage Containers	2-5
Missile-Round Container	2-5
Weapon-Round Container	2-5
Short Range Air Defense Engagement Zone (SHORADEZ)	3-16
Signal Security (SIGSEC)	B-8
Small Arms in the Air Defense Role	D-1
Snow Blindness	9-1
SOPs and Combat Orders	
Command Signal	6-4
Execution	6-4
Mission	6-4
Operations Orders	6-4
Service Support	6-4
Situation	6-4
Supplies, Equipment, and Special Tasks	6-5
Terrain and Weather	6-5
Threat	6-5
Special Command Statuses	3-9
Standard-Use Army Aircraft Routes	3-19
States of Alert	3-15
Red - Battle Stations	3-15
White - Stand Down	3-15
Yellow - Standby	3-15
Static Critical Asset Defense	5-10
Stinger Command Structure	3-8
Stinger Defense Design Requirements	5-7
AD Priorities	5-7
In an NBC Environment	7-6
Number of Teams Available	5-10
Scheme of Maneuver	5-7
Tactical and Technical Requirements	5-8
Terrain and Weather	5-10
Threat	5-8

	Page
Stinger-Peculiar Items	10-1
Battery/Coolant Units	10-2
IFF Systems	10-2
Shipping and Storage Containers	10-2
TADDS	10-2
Training Equipment	10-2
Weapon Round/Missile Round	10-1
Stinger Platoon Operations	6-1
Identification, Friend or Foe (IFF), Subsystem	2-3
Shipping and Storage Containers	2-5
Transport Harness	2-6
Weapon Round	2-1
Suffixes	B-12
Sunburn	9-2
Supplemental Fire Control Measures	3-16
Supply	10-3
Superelevation, Lead, and Launch	2-8
Support of Special Operations	9-1
Suppressive Attacks	B-3
Tactical and Technical Requirements	5-8
Accessibility for Team Vehicles	5-9
Communications	5-8
Cover and Concealment	5-9
Observation and Fields of Fire	5-8
Physical Security	5-9
Technical Requirements	5-9
Tactical Missions	5-2
Temporary Airspace Restriction Measures	3-17
Threat Air Forces	
Airborne Assault	1-15
Aircraft and Capabilities	1-2
Air Strikes	1-1
Ground Attack Aircraft	1-4
Heliborne Assault	1-15
Helicopters	1-6
Multirole Aircraft	1-2
Tactical Aerial Reconnaissance	1-2
Tactical Reconnaissance Aircraft	1-5
Threat Intelligence Collection Measures	B-1
Transport Harness	2-6

	Page
Troop Leading Procedures	6-2
Complete the Plan	6-3
Initiate Necessary Movement	6-2
Issue a Warning Order	6-2
Issue Orders	6-3
Make a Tentative Plan	6-2
Receive the Mission	6-2
Reconnaissance	6-3
Supervise and Refine	6-3
TSEC/K1-1A System	2-4
Types of Air Defense	5-5
Types of Jamming Signals	B-3
Using the CEOI	4-10
Volume	D-3
Warning Procedures and Alert Statuses	3-15
Red	3-15
White	3-15
Yellow	3-15
Weapon Activation	2-7
Weapon Round	2-1,2-2
Weapons Control Statuses	3-14
Weapons Free	3-15
Weapons Hold	3-15
Weapons Tight	3-15
When to Fire	D-1
Whiteout	9-6
Wire Communications	4-8

30 SEPTEMBER 1981

By Order of the Secretary of the Army:

E. C. MEYER
General, United States Army
Chief of Staff

Official:

ROBERT M. JOYCE
Brigadier General, United States Army
The Adjutant General

DISTRIBUTION:

Active Army, ARNG, and USAR: To be distributed in accordance with DA Form 12-11A & B, Requirements for REDEYE Guided Missile System (Qty rqr block no. 192); US Army Air Defense Artillery Employment (Qty rqr block no. 348); Operations of Army Forces in the Field (Qty rqr block no. 405); and Army Airspace Control Doctrine (Qty rqr block no. 426).

Additional copies may be requisitioned from the US Army Adjutant General Publications Center, 2800 Eastern Boulevard, Baltimore, MD 21220.